

Visit

FreeTestPaper.com

for more papers

ANGLO-CHINESE SCHOOL
(INDEPENDENT)



Year 4 Express
Preliminary Examination 2016

CHEMISTRY
PAPER 1 Multiple Choice
Friday

5073/1

12 August 2016

1 hour

Additional materials:

- Calculator
- Multiple Choice answer sheet
- Soft clean eraser
- Soft pencil (type 2B recommended)

TIME 1 hour

INSTRUCTIONS TO CANDIDATES

Do not open this booklet until you are told to do so.

Write and shade Candidate number on the answer sheet in the spaces provided.

There are **forty** questions in this paper. Answer **all** questions. For each question there are four possible answers, **A, B, C** and **D**. Choose the **one** you consider correct and record your choice in **soft pencil** on the separate answer sheet.

Read very carefully the instructions on the answer sheet.

INFORMATION FOR CANDIDATES

Each correct answer will score one mark. A mark will not be deducted for a wrong answer.
Any rough working should be done in this booklet.

You may use a calculator.

A copy of the Periodic Table is printed on page 14.

This question paper consists of 14 printed pages.

- 8 Which of the following substances conducts electricity using delocalized electrons and burns in oxygen to form a gas?
- A Graphite
B Sodium chloride
C Magnesium
D Hydrogen
- 9 The solubility of common salt is 36 g/100cm³ at 25 °C. Which one of these is **not** a saturated solution of common salt?
- A 18 g dissolved in 0.5 dm³ water at 25°C
B 9 g dissolved in 25 cm³ water at 25°C
C 54 g dissolved in 150 cm³ water at 25°C
D 72 g dissolved in 200 cm³ water at 25°C
- 10 What is the total number of subatomic particles found in the nuclei of two ammonia molecules?
- A 10
B 17
C 20
D 34
- 11 The mass of diamond is expressed in a unit called the carat. One carat is equivalent to a mass of 0.200-g. Which of the following is closest to the number of atoms in a 0.500 carat diamond?
(1 mole = 6 x 10²³ particles)
- A 2.50 x 10²¹
B 5.00 x 10²¹
C 1.00 x 10²²
D 2.00 x 10²²
- 12 A mixture containing 1 mole of ethene and 4 moles of oxygen is ignited in a sealed container at 300°C. The reaction that occurs is represented by the equation
- $$\text{C}_2\text{H}_4(\text{g}) + 3\text{O}_2(\text{g}) \rightarrow 2\text{CO}_2(\text{g}) + 2\text{H}_2\text{O}(\text{g})$$
- What is the total number of moles of gases at the end of the reaction?
- A 2
B 3
C 4
D 5

13 A sample of hydrogen chloride gas is added into methylbenzene, an organic solvent. Which statement correctly describes the mixture?

- A Hydrogen chloride is insoluble in methylbenzene and **cannot** dissociate into ions.
- B Hydrogen chloride is insoluble in methylbenzene but dissociates into ions.
- C Hydrogen chloride dissolves in methylbenzene but does **not** dissociate into ions.
- D Hydrogen chloride dissolves in methylbenzene and dissociates into ions.

14 In which reaction is the sulfate ion removed from the solution?

- A $\text{BaCl}_2 + \text{H}_2\text{SO}_4 \rightarrow \text{BaSO}_4 + 2\text{HCl}$
- B $2\text{NaOH} + \text{H}_2\text{SO}_4 \rightarrow \text{Na}_2\text{SO}_4 + 2\text{H}_2\text{O}$
- C $\text{Mg} + \text{H}_2\text{SO}_4 \rightarrow \text{MgSO}_4 + \text{H}_2$
- D $\text{Na}_2\text{CO}_3 + \text{H}_2\text{SO}_4 \rightarrow \text{Na}_2\text{SO}_4 + \text{H}_2\text{O} + \text{CO}_2$

15 The table shows information about 3 indicators.

indicator	colour at pH 1	pH at which colour changes	colour at pH 12
thymol blue	red	3	yellow
congo red	blue	5	red
phenolphthalein	colourless	10	red

A solution X shows

yellow in thymol blue,
red in congo red and
red in phenolphthalein.

Which of the statements below about solution X is true?

- A It could be pure water
- B It could be aqueous sodium carbonate
- C Its pH is at least 3.
- D It could be aqueous potassium hydroxide

16

M is the symbol used for a metallic element. Which one of the following reactions could **not** be represented by the ionic equation below?



- A Zinc + dilute hydrochloric acid
- B Copper + dilute hydrochloric acid
- C Iron + dilute sulfuric acid
- D Magnesium + dilute sulfuric acid

17 Aqueous solution of **X** reacts with the following reagents to form white precipitates.

- i excess aqueous sodium hydroxide
- ii aqueous sodium sulfate
- iii aqueous silver nitrate

What could be a possible identity of **X**?

- A Aluminum chloride
- B Calcium chloride
- C Sodium chloride
- D Zinc chloride

18 Which of the following reagents is most suitable in differentiating sulfur dioxide gas from carbon dioxide gas?

- A Acidified potassium manganate(VII)
- B Aqueous sodium hydroxide
- C Aqueous sodium carbonate
- D Moist blue litmus paper.

19 Which of the following substances does **not** react with warm aqueous potassium hydroxide?

- A Solid aluminium oxide
- B Solid ammonium chloride
- C Aqueous copper(II) sulfate
- D Aqueous sodium sulfate

20 What are the colour changes observed when excess aqueous potassium iodide is added slowly to aqueous acidified potassium manganate(VII)?

- A colourless → brown
- B colourless → purple
- C purple → brown
- D purple → colourless

21 Element Z has the following properties.

- It has high melting and boiling points.
- It oxidises readily to form compounds with oxidation states of +2 and +3.
- It helps to lower the activation energy of a reaction.

What part of the Periodic table would you find Element Z?

- | | | | |
|---|--------------|---|-------------------|
| A | Alkali metal | C | Noble gas |
| B | Halogen | D | Transition metal. |

22 Rubidium, Rb, is an element in the same group of the Periodic Table as lithium, sodium and potassium. Which statement about rubidium is likely to be correct?

- A It forms a sulfate, Rb_2SO_4 .
- B It forms an insoluble hydroxide.
- C It is formed by the electrolysis of aqueous rubidium chloride.
- D It reacts slowly with water at 20°C .

23 Methane gas reacts extremely slowly with air at room temperature. If a piece of platinum is held in a methane-air mixture, the methane ignites. What conclusion can be made about the use of platinum in this reaction?

- A The activation energy is lower.
- B The energy change has increased.
- C The energy of the reactants is raised.
- D There is a decrease in the rate of reaction.

24 When steam is passed through white-hot coke, a reaction occurs and the temperature of the coke falls. What does this indicate?

- A The heat change of the reaction is negative.
- B The heat change of the reaction is positive.
- C Coke is reduced by steam.
- D The energy content of the coke has decreased.

- 25 The graph shows how the total volume of hydrogen produced changed when iron filings reacted with excess dilute sulfuric acid.

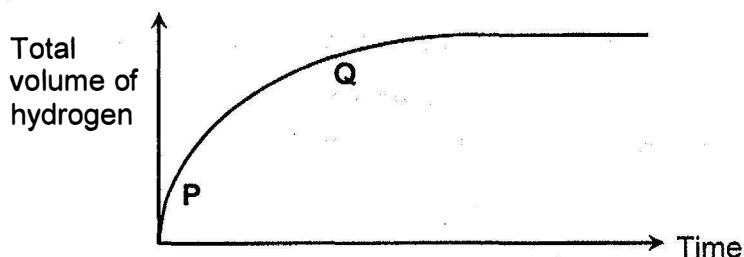

Which statement best describes the section PQ of the curve?

- A The sulfuric acid is a strong acid.
 B The iron filings is reducing in mass and this slows down the reaction.
 C Water is produced and it dilutes the acid which slows down the reaction.
 D Hydrogen gas produced slows down the reaction.
- 26 Aqueous hydrogen peroxide decomposes according to the following equation.

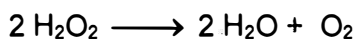

Two experiments were carried out to measure the rate of production of oxygen from aqueous hydrogen peroxide. The results are given below.

Experiment	Solution Used
X	100 cm ³ of 2 mol/dm ³ H ₂ O ₂
Y	100 cm ³ of 2 mol/dm ³ H ₂ O ₂ and 50 cm ³ of 1 mol/dm ³ H ₂ O ₂

Which graph best shows the results of the two experiments?

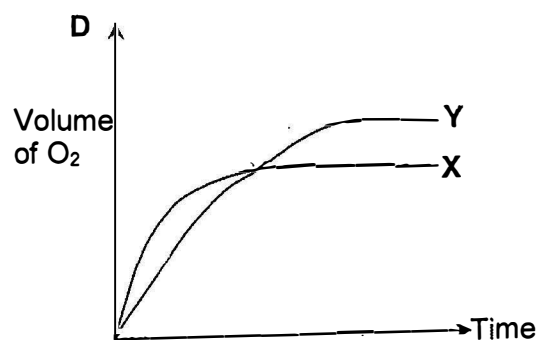
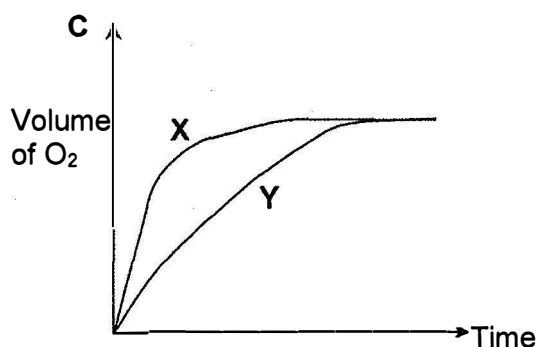
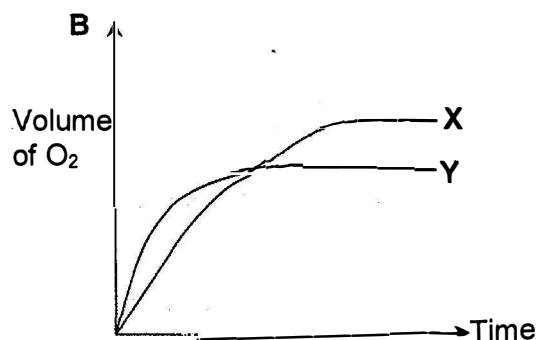
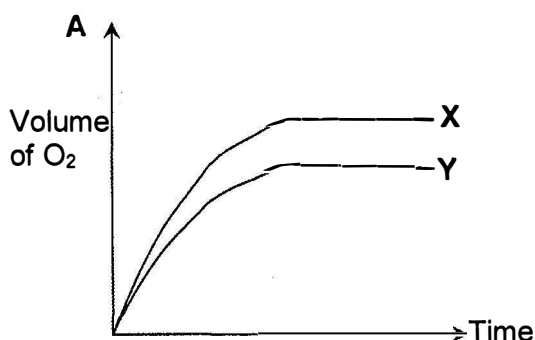

- 27 The following energy level diagram represents the reaction between hydrogen and oxygen to form steam.

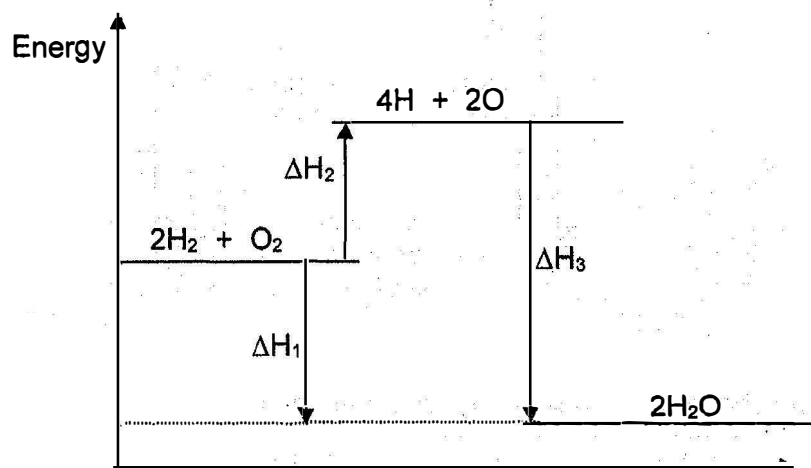
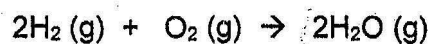

Which of the following represents the energy required for bond breaking and the energy released when new bonds are formed?

	energy required for bond breaking	energy released for bond formation
A	ΔH_2	ΔH_3
B	ΔH_2	ΔH_1
C	ΔH_1	ΔH_2
D	ΔH_1	ΔH_3

- 28 Which of the following correctly shows the energy profile of an endothermic reaction? [E_a is the activation energy for the reaction.]

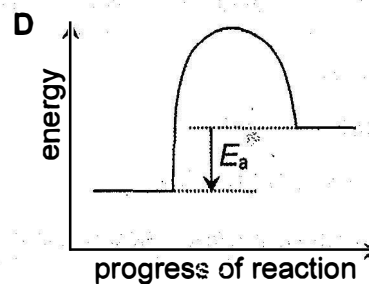
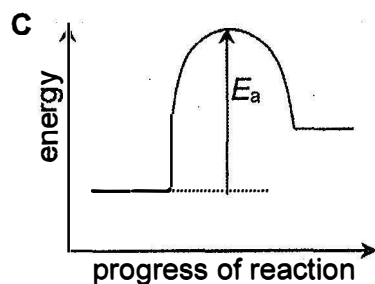
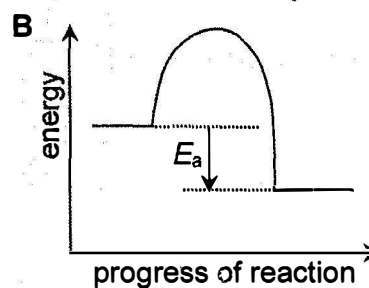
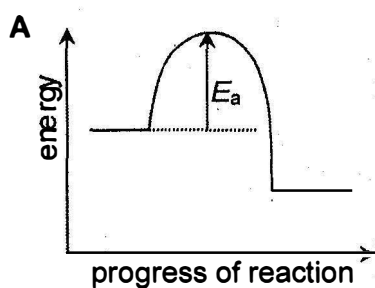

- 29 The diagram shows two electrolysis cells, X and Y.

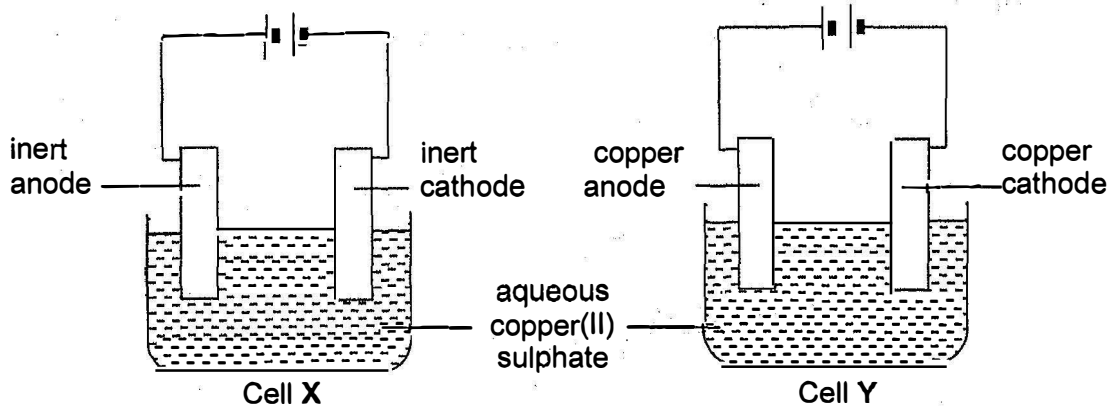

What are the changes in mass, if any, of the anodes?

	Cell X	Cell Y
A	decrease	decrease
B	no change	no change
C	increase	no change
D	no change	decrease

- 30 An electrolyte was electrolysed as shown in the diagram below. Two gaseous products are collected:

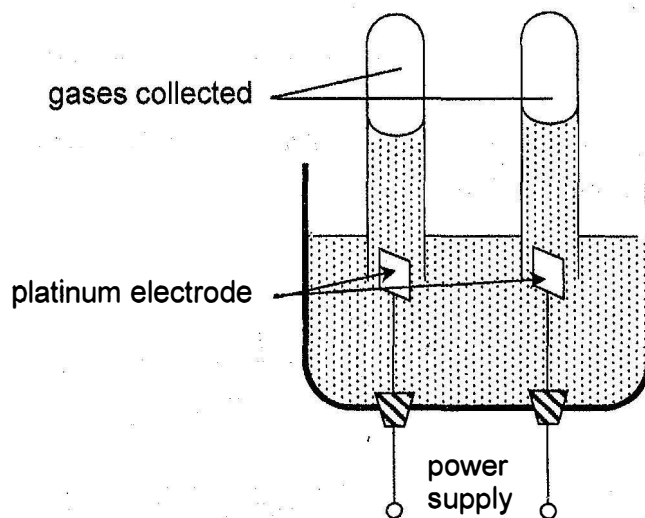

What is the electrolyte most likely to be?

- A** pure water
- B** dilute sulfuric acid
- C** molten lead(II) bromide
- D** concentrated aqueous sodium chloride

31 A current is pass through the following electrolytes using inert electrodes. Which one will produce an alkaline solution at the end of the electrolysis?

- A Aqueous sodium sulfate C Aqueous copper(II) nitrate
 B Dilute sulfuric acid D Concentrated potassium chloride

32 The diagram below shows a catalytic converter fitted to the exhaust system of a car.

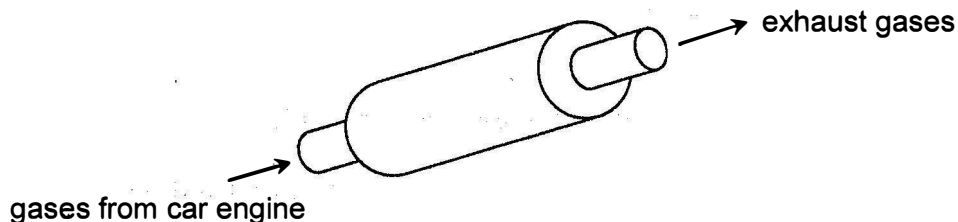

Which of the following pollutants from the car engine undergo reactions in the catalytic converter to produce less harmful products?

1	Carbon dioxide
2	Hydrocarbons
3	Oxides of nitrogen

- A 1 and 2 only
 B 1 and 3 only
 C 2 and 3 only
 D 1, 2 and 3
- 33 Which of the following is not a source of nitrogen oxides?

- A Bacterial decay of vegetation.
 B Blast Furnace.
 C Combustion engines of vehicles.
 D Lightning during a thunderstorm.

34 The diagrams below show four pieces of metal strips of equal size tied together in dilute hydrochloric acid. After five minutes, which beaker will contain the **least** iron ions in the solution?

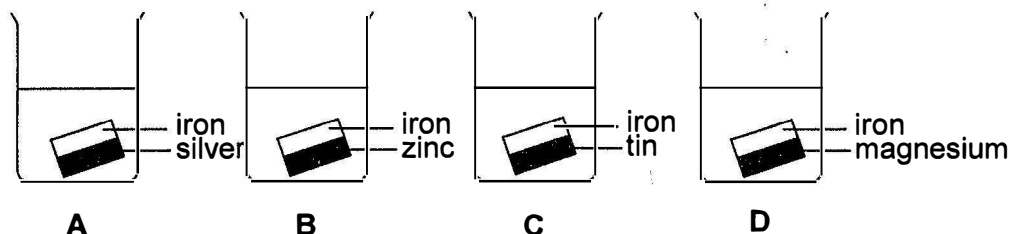

35 The position of metal **M** in the reactivity series is shown below.

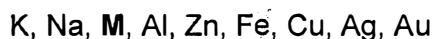

Which method will be used to extract **M** from its ore?

- A Electrolysis of its molten oxide.
- B Electrolysis of its aqueous sulfate.
- C Reduction of its oxide by heating with hydrogen.
- D Reduction of its oxide by heating with coke.

36 Metals **P**, **Q**, **R** and **S** are found to have the following properties.

- i Only oxides of **P** and **R** can be reduced by heating with carbon.
- ii **P** and **Q** react with acid but not with cold water. **R** does **not** react both with acid and water.
- iii Carbonate of **S** does **not** decompose on heating.

The order of increasing reactivity of the 4 metals is:

- A **P**, **Q**, **R** and **S**
- B **R**, **P**, **Q** and **S**
- C **R**, **P**, **S** and **Q**
- D **S**, **Q**, **P** and **R**

37 The structural formula of butenedioic acid is shown. Which statement about butenedioic acid is **incorrect**?

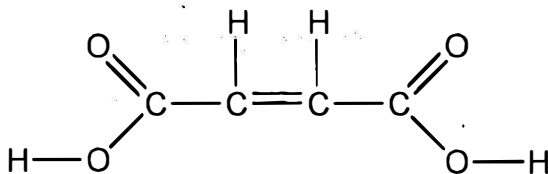

- A It reacts with hydrogen when warmed with nickel catalyst.
- B It has a relative molecular mass of 116.
- C Its aqueous solution reacts with sodium carbonate.
- D It can be oxidized using acidified potassium dichromate(VI).

38 Which organic compound has the empirical formula CH_2O and reacts with sodium hydroxide?

- A Ethanol
B Ethyl ethanoate
C Ethanoic acid
D Glucose

39 An unsaturated fatty acid has the molecular formula $\text{C}_{17}\text{H}_{31}\text{CO}_2\text{H}$. How many carbon-carbon double bonds are present in one molecule of the fatty acid?

- A 1
B 2
C 3
D 4

40 How many isomers are there in $\text{C}_3\text{H}_8\text{Cl}_2$?

- A 2
B 3
C 4
D 5

Candidate Number

--

**ANGLO-CHINESE SCHOOL
(INDEPENDENT)**



**Year 4 Express
Preliminary Examination 2016**

**CHEMISTRY
PAPER 2 Theory**

5073/2

Wednesday

27 JULY 2016

1 hour 45 minutes

Candidates answer on the Question Paper.
Calculator

TIME 1 hour 45 minutes

INSTRUCTIONS TO CANDIDATES

Write your Candidate number in the spaces at the top of this page and on any separate answer paper used.

Section A

Answer **all** questions.

Write your answer in the spaces provided on the question paper.

Section B

Answer all **three** questions from this section.

The last question is in the form **EITHER / OR** and **only one** alternative should be attempted.

Write your answers on the answer paper provided.

At the end of the examination, hand up the paper in one bundle.

INFORMATION FOR CANDIDATES

The number of marks is given in brackets [] at the end of each question or part question.

A copy of the Periodic Table is printed on page 18.

You may use a calculator.

FOR EXAMINER'S USE	
Section A	
B7	
B8	
B9	
TOTAL	

This question paper consists of 18 printed pages.

Section A

Answer **all** questions in the spaces provided.

The total mark for this section is 50.

- A1** Vanadium(V) oxide, V_2O_5 , is obtained by thermal decomposition of ammonium metavanadate, NH_4VO_3 . The other products formed are **ammonia gas** and **water**.
- a** Write a balanced chemical equation for the action of heat on ammonium metavanadate. [1]
-
- b** Explain, in terms of the oxidation states of vanadium, why the reaction in **(a)** is **not** a redox reaction. [1]
- c** Vanadium is a transition metal. Using this information, suggest a property of [1]
-
- d** **(i)** Vanadium(V) oxide dissolves in strong alkali to form the VO_4^{3-} ion and in strong acid to form the VO_2^+ ion. What is the term used to describe this property of vanadium(V) oxide? [1]
- ii** State another transition element that can also exhibit the property described in **d(i)**. [1]

[Total: 5 marks]

- A2 The figure below shows the flow chart for a series of chemical reactions involving dilute hydrochloric acid.

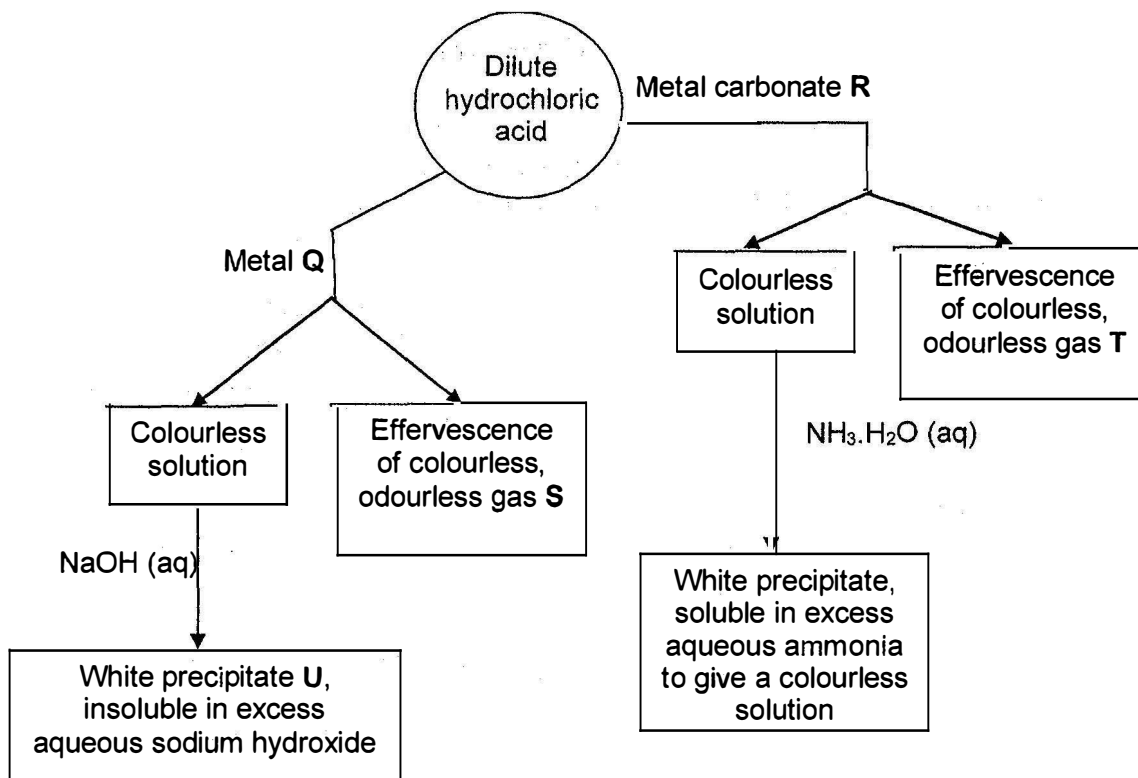

- a Describe a chemical test for the anion present in dilute hydrochloric acid. [2]
- b State the chemical formulae of the following substances. [3]
- | | |
|-------------------|-------------------|
| <p>Q</p> <p>S</p> | <p>R</p> <p>T</p> |
|-------------------|-------------------|
- c Write the ionic equation, including state symbols, for the formation of white precipitate U. [2]
- d i Explain what is meant by oxidation in terms of **electron transfer**. [1]
- ii One of the reactions above is a redox reaction
Write the equation of the redox reaction. [1]

[Total: 9 marks]

A3 Air is a mixture of gases where the main constituents are nitrogen and oxygen.

a State the percentage compositions of clean atmospheric nitrogen and oxygen. [1]

b In an experiment to investigate the combustion of carbon, oxygen is passed over heated carbon powder. The gas mixture is then bubbled into limewater and finally collected in a gas syringe. The set-up is shown below.

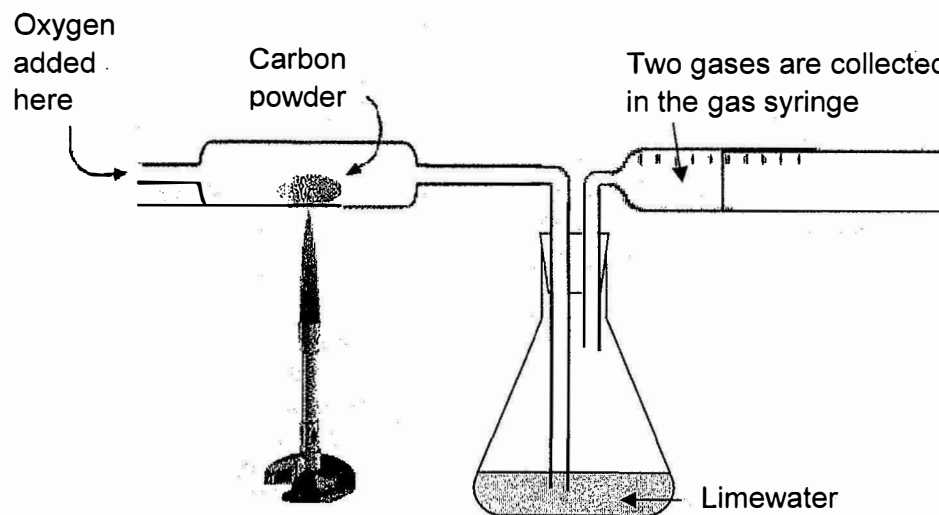

i State the observation in the limewater. [1]

ii Two gases are collected in the gas syringe and one of them has a reducing property.

Name the two gases and explain how the gas with the **reducing property** is produced and present in the gas syringe. [3]

- c Large quantities of ammonia are manufactured by the Haber process. The graphs below show the yield of ammonia at different temperatures and pressures.

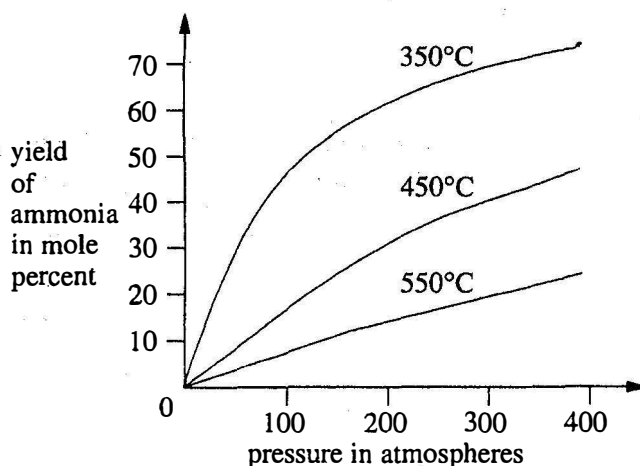

- i Describe the trend between the yield of ammonia and temperature. [1]

- ii Describe the trend between the yield of ammonia and pressure. [1]

- iii Suggest why 200 atmospheres is preferred over a higher pressure of 400 atmospheres in the Haber Process. [1]

- iv The equation for the Haber process is

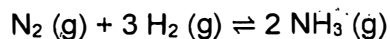

- Explain why the yield of ammonia cannot be 100 percent? [1]

- v Ammonia gas is chemically tested with moist red litmus paper. Explain why it is necessary for the litmus paper to be moist. [1]

[Total: 10 marks]

- A4** The table shows information of the alkynes homologous series which consists of unsaturated hydrocarbons. Each member of this series contains a carbon-carbon triple bond.

Name of Alkynes	Number of carbon atoms	Structural Formula	Boiling point/ $^{\circ}\text{C}$
ethyne	2	$\text{H}-\text{C}\equiv\text{C}-\text{H}$	-75
propyne	3	$\begin{array}{c} \text{H} \\ \\ \text{H}-\text{C}-\text{C}\equiv\text{C}-\text{H} \\ \\ \text{H} \end{array}$	-23
	4	H	9
pentyne	5	$\begin{array}{ccccccc} & \text{H} & \text{H} & \text{H} & & & \\ & & & & & & \\ \text{H} & -\text{C} & -\text{C} & -\text{C} & -\text{C}\equiv\text{C} & -\text{H} & \\ & & & & & & \\ & \text{H} & \text{H} & \text{H} & & & \end{array}$	40

- a** Explain what is meant by term **homologous series**. [2]
- b** Describe and explain the trend in boiling points in the alkyne homologous series. [2]
- c** In the spaces provided, deduce the ^{ng} **name** and **structural formula** of the alkyne that contains 4 carbon atoms. [1]

- d The reaction scheme below shows a series of reactions starting with propyne.

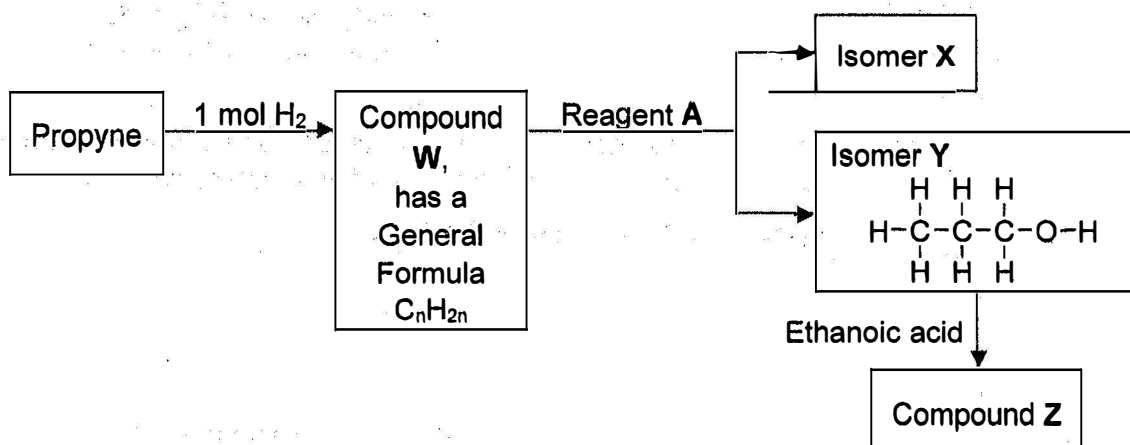

- i Draw the structural formula of the compound **W** formed when propyne reacts with **one** mole of hydrogen gas. [1]
- ii Name reagent **A** which reacts with compound **W** to form isomers **X** and **Y**. [1]
- iii Draw the structural formula of isomer **X**. [1]
- iv Name the sweet smelling compound **Z** and draw its structural formula. [2]

[Total: 10 marks]

A5 The graphs below show the results of the reactions between two acids and excess calcium carbonate.

In experiment I, 100 cm³ of 0.50 mol/dm³ **dilute nitric acid** was reacted with excess calcium carbonate lumps.

Experiment II was a repeat of experiment I except that 100 cm³ of 0.5 mol/dm³ **dilute sulfuric acid** was used instead of dilute nitric acid. All other variables were kept constant.

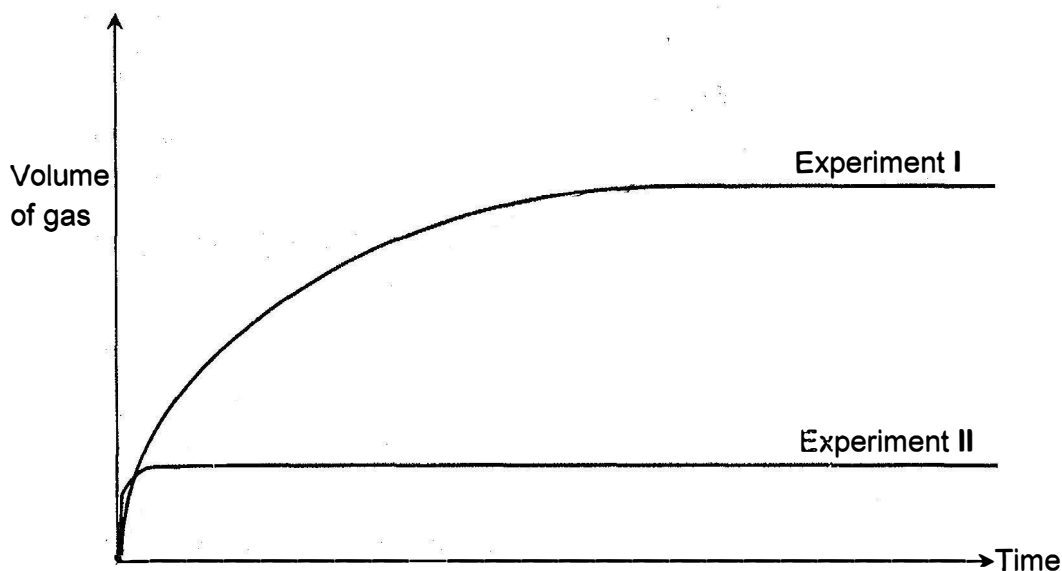

- a Comparing the graphs in Experiments I and II,
i explain why the gradient is steeper in experiment I.

- ii Explain why the volume of gas produced is less in experiments II [2]

- b Experiment III was similar to Experiment I but 100 cm³ of 0.50 mol/dm³ **butanoic acid** was used instead of dilute nitric acid.

- i Write the chemical equation for the reaction between butanoic acid and calcium carbonate [2]

- ii On the same axes, sketch the graph for experiment III and label it X. [1]

- iii The reaction above can be used to make a pure and dry sample of the salt, hydrated calcium butanoate. An outline of the procedure is given below.

"An excess of calcium carbonate is added to a warm solution of butanoic acid. The mixture is filtered and then crystallisation is carried out. The salt is dried with filter paper and should not be heated directly."

Explain why the three underlined steps are important in the procedure. [3]

[Total: 10 marks]

- A6 In separate experiments, powdered samples of metals P and Q were reacted with solutions of nickel(II) nitrate and iron(II) nitrate respectively. The table shows how the colours of the solutions changed.

	Nickel(II) nitrate	Iron(II) nitrate
Metal P	Solution turns from green to colourless. P is coated with a shiny grey solid.	Solution stays pale green.
Metal Q	Solution goes from green to colourless. Q is coated with a shiny grey solid.	Solution goes from pale green to colourless. Q is coated with a grey solid.

- a Arrange the four metals, P, Q, nickel and iron in order of **increasing** reactivity. [2]
- b Nickel is higher in the reactivity series of metals than hydrogen. In a reaction, excess nickel was placed in aqueous silver nitrate.
- i Describe two observations for the reaction. [2]
- ii Write the ionic equation, with state symbols for the reaction. [2]

[Total: 6 marks]

Section B

Answer all **three** questions from this section.

The last question is in the form **EITHER / OR** and **only one** alternative should be attempted.

Tie any extra sheets used loosely to this booklet.

- B7** The diagram below shows a new process that uses electrolysis for the direct reduction of solid titanium(IV) oxide (TiO_2) to extract titanium metal. Titanium has many desirable properties. It is light, strong and corrosion-resistant. Its use has been restricted because of the high processing cost of current available extraction methods:

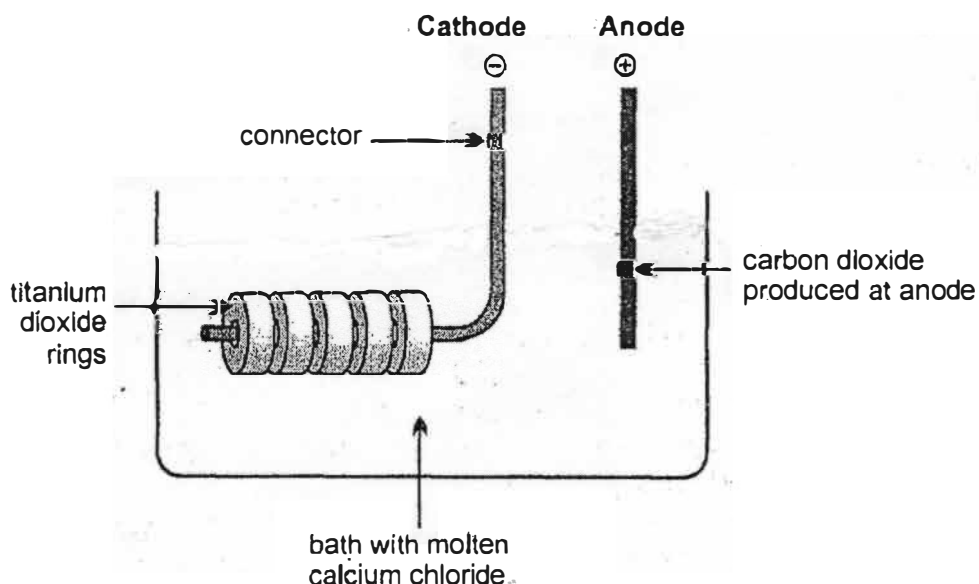

A voltage is set up between the cathode and anode. The titanium(IV) oxide (rings) gain electrons and releases oxide ions, which dissolve into the molten calcium chloride bath leaving pure solid titanium metal at the cathode. At the same time, oxide ions are discharged at the anode to form oxygen gas which then reacts with the carbon anode to form carbon dioxide. The process takes place between 900 and 1100 °C.

- a** Based on the information provided, write down the ionic equation for the reaction occurring at the cathode (include state symbols). ..
-
- b** Suggest why the electrolysis cell needs to be operated at a temperature of between 900 °C to 1100 °C? [1]

- c** What is the purpose of the molten calcium chloride bath?
- d** Write down the half-equation, with state symbols, for the formation of oxygen gas at the anode.
- e** In an industrial process, 4.8 tonnes of the titanium(IV) oxide rings was used. Calculate the maximum mass of titanium metal that can be extracted. [2]
- f** At the start of the electrolysis, it was noticed that the gas formed was not colourless. Name this gas and explain why it was formed instead. [2]

[Total: 10 marks]

B8 Acrylonitrile has the chemical formula C_3H_3N . Its structural formula is shown below.

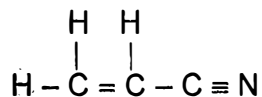

The reaction scheme below shows the reactions of acrylonitrile to form poly(acrylonitrile) and nylon 4,6.

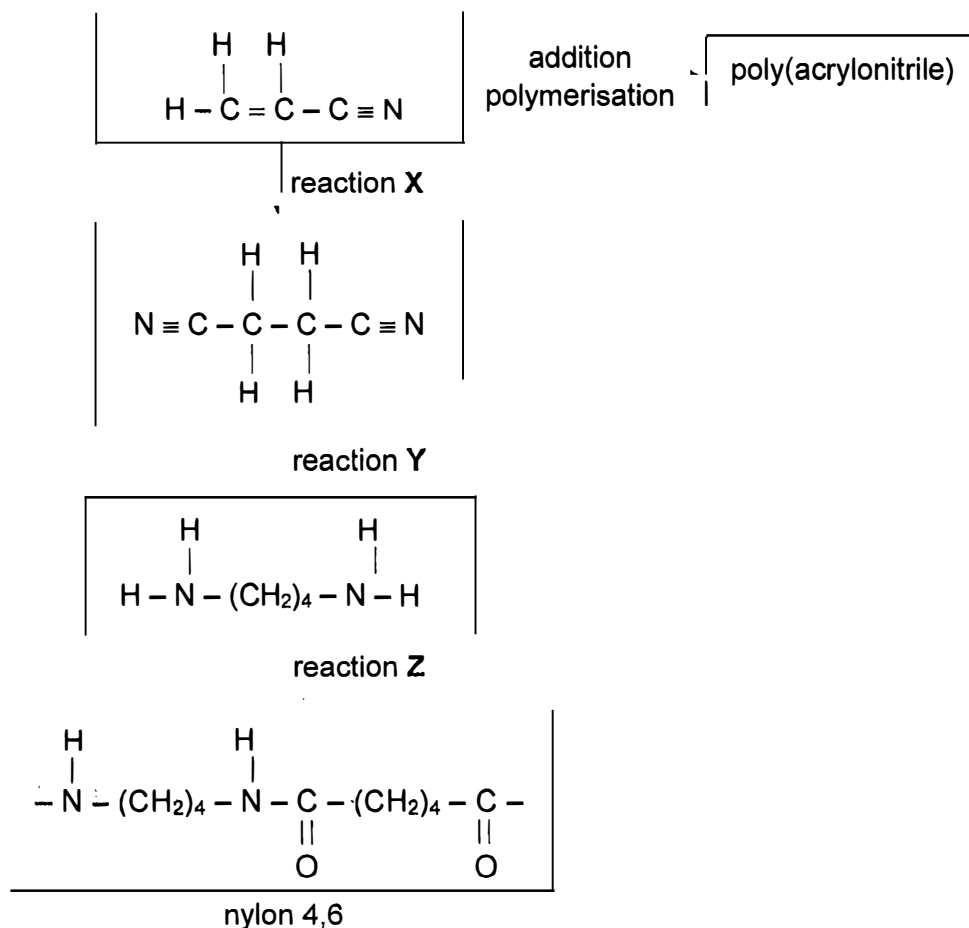

- a** Describe the test to show that acrylonitrile is an unsaturated compound. [2]

Acrylonitrile undergoes addition polymerisation to form the polymer poly(acrylonitrile).

- Draw the structure of part of this polymer, showing three repeat units. [2]

- c State the chemical formula of the reagent used in reaction X. [1]
- d Draw the full structural formula of the reagent that is involved in reaction Z. [1]
- e Nylon 4,6 is synthetic material that has many uses in industries. State one advantage and one disadvantage of using Nylon 4,6. [2]
- f Describe two differences between the processes involved in addition polymerisation and condensation polymerisation [2]

[Total: 10 marks]

For
Examiner's
use

EITHER

B9 In 1705, Abraham Darby proposed the extraction of iron from its ore using coke in a blast furnace.

a The table below shows two common iron ores found on our planet.

Name of ore	Chemical formula
haematite	Fe_2O_3
magnetite	Fe_3O_4

Write the equation for the extraction of iron from haematite in the blast furnace.

[1]

ii Show by chemical calculations, which iron ore will produce the largest volume of carbon dioxide gas per kilogram of the ore? [3]

b The diagram below shows the Blast Furnace.

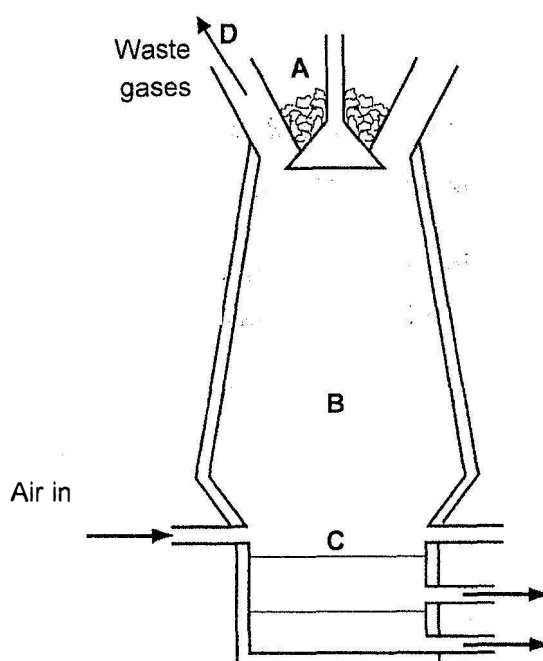

- i Iron ore is added at A, name the other substances that are fed into the furnace at A. [1]
-
- ii Why might the furnace explode if damp substances were added at A? [2]
- iii Describe, with the aid of chemical equation(s), the removal of the main impurity from the iron ore. [2]
- iv Explain why nitrogen is the main substance found in the waste gases at D. [1]

[Total: 10 marks]

OR

B9 Hydrazine is used as a rocket propellant. It works by undergoing a chemical reaction to produce a large volume of hot gas that provides the thrust to propel the rocket.

A gaseous mixture of hydrazine (N_2H_4) and hydrogen peroxide (H_2O_2) reacts very quickly to produce nitrogen and steam. 843 kJ of energy is produced for every mole of hydrazine that reacts. The equation is shown below:

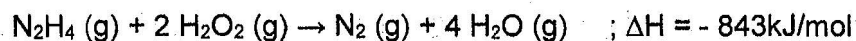

- a** With reference to the equation above, explain why this reaction is effective in propelling rockets. [2]

- b** Calculate the energy given out when 12 kg of hydrogen peroxide has reacted. [2]

- c** Draw a 'dot-and-cross' diagram to show the bonding in a hydrazine molecule. Show outer electrons only. [2]

- d** Explain why it is advantageous to store hydrazine and hydrogen peroxide as liquids in the rocket rather than as gases. [1]

- e** Explain in terms of bond breaking and bond forming why the above reaction has a negative enthalpy change. [3]

[Total: 10 marks]

BLANK PAGE

P1

1	2	3	4	5	6	7	8	9	10	11	12	13	14	15	16	17	18	19	20
D	C	B	C	B	C	A	A	A	D	B	D	C	A	D	B	B	A	D	C
21	22	23	24	25	26	27	28	29	30	31	32	33	34	35	36	37	38	39	40
D	A	A	B	B	D	A	C	D	D	D	C	A	D	A	B	D	C	B	C

P2

- A1**
- a $2\text{NH}_4\text{VO}_3 (\text{s}) \rightarrow \text{V}_2\text{O}_5 (\text{s}) + 2\text{NH}_3 (\text{g}) + \text{H}_2\text{O} (\text{l})$
- b Oxidation state of vanadium in NH_4VO_3 is +5 and remains as +5 in V_2O_5 after the reaction. (do not accept: 5+ or 5)
- c Vanadium forms coloured compounds.
It could be used as a catalyst. (accept: high melting point) (do not accept: variable oxidation states)
- d i Amphoteric oxide (accept amphoteric) (do not accept: variable oxidation states)
- ii Zinc (do not accept: other TM)
- A2**
- a Add aqueous silver nitrate and a white precipitate if formed.
- b
- | | | | | | |
|--|---|----------------|--|---|-------------------|
| | Q | Ca | | R | ZnCO ₃ |
| | S | H ₂ | | T | CO ₂ |
- c $\text{Ca}^{2+} (\text{aq}) + 2\text{OH}^- (\text{aq}) \rightarrow \text{Ca}(\text{OH})_2 (\text{s})$
- d i When an atom or ion loses electrons to another atom or ion.
(Calcium atoms loses electrons to H⁺ ions form Ca²⁺ ions or H⁺ ions gain electrons from calcium atoms to form hydrogen gas)
- ii $\text{Ca} + 2\text{HCl} \rightarrow \text{CaCl}_2 + \text{H}_2$
- A3**
- a Nitrogen is 78% and oxygen is 21% (do not accept any variances)
- b i A white precipitate is formed.
- ii Carbon monoxide and oxygen
Carbon monoxide is from the incomplete combustion of the carbon powder, CO is insoluble in limewater.
- c i As temperature rises, the yield of ammonia decreases.
- ii As the pressure increases, the yield of ammonia increases.
- iii 200 atmospheres could be the optimal pressure for industrial vessels.
Building and maintenance costs facilities are too high for 400 atmospheres (or OWTTE). (do not accept: easier to "produce" or simply "cheaper" or "less costly")
- iv It's a reversible reaction. While ammonia is formed, it is also decomposed back into nitrogen and hydrogen. ("forward and backward" phrases must be accompanied by describing the reaction as reversible)
- v Ammonia gas needs to dissolve in water to form an alkali and produce hydroxide ions. (either alkali or hydroxide) (do not accept: "dissociate in water")

- A4 a A homologous series consists organic molecules
 - with the same general formula
 - same functional group
 - of adjacent members differ by a $-CH_2-$ group of atoms

b As the number of carbon atoms in the molecules increases, the boiling point increase. With bigger molecules, the intermolecular forces are stronger and results in higher boiling points.

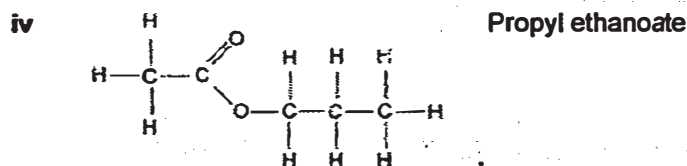
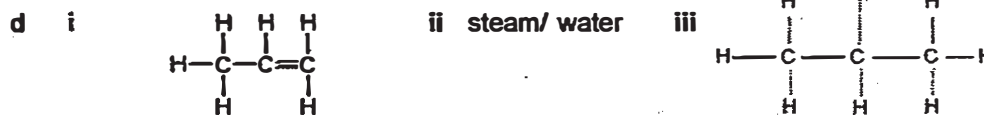
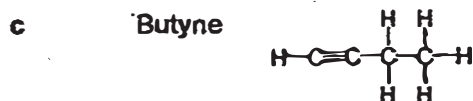

- A5 a i Dilute sulfuric acid is a dibasic acid a dilute nitric acid is a monobasic acid. Dilute sulfuric acid dissociates to produce twice the concentration of hydrogen ions as dilute nitric acid. A higher concentration of hydrogen ions results in an increase in the probability of effective collision resulting in faster rate of reaction and steeper gradient.

ii Calcium sulfate is the insoluble salt formed by dilute sulfuric acid, which forms a coating on solid calcium carbonate and prevents further reaction.

Calcium nitrate is a soluble salt and dilute nitric acid reacts completely.

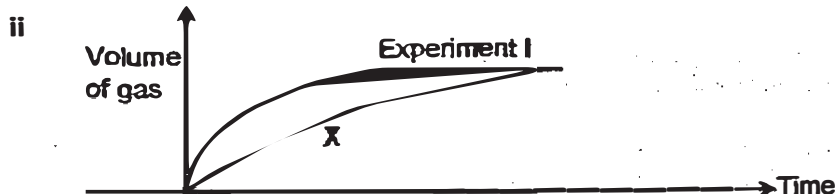
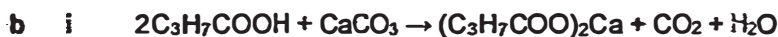

- iii excess of calcium carbonate is added to ensure all the butanoic acid has reacted completely.
 Filtration is carried out to remove the excess calcium carbonate.
 Heating of the crystals is disallowed to retain the water of crystallization or to prevent decomposition of the salt.

A6 a nickel, P, iron, Q.

b i Shiny grey solid is formed on nickel.
 The colourless solution turns into a green solution.

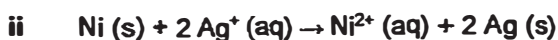

EITHER

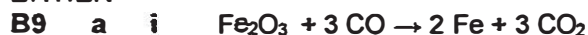

- ii Mr of $\text{Fe}_2\text{O}_3 = 56 \times 2 + (16 \times 3) = 160$
No of mol of $\text{Fe}_2\text{O}_3 = 1000/160 = 6.25 \text{ mol}$
No of mol of CO_2 from $\text{Fe}_2\text{O}_3 = 6.25 \times 3 = 18.75 \text{ mol}$
Vol. of CO_2 from $\text{Fe}_2\text{O}_3 = 18.75 \times 24 = 450 \text{ dm}^3$

- Mr of $\text{Fe}_3\text{O}_4 = 56 \times 3 + (16 \times 4) = 232$
No of mol of $\text{Fe}_3\text{O}_4 = 1000/232 = 4.31 \text{ mol}$
No of mol of CO_2 from $\text{Fe}_3\text{O}_4 = 4.32 \times 4 = 17.3 \text{ mol}$
Vol. of mol of CO_2 from $\text{Fe}_3\text{O}_4 = 17.3 \times 24 = 415 \text{ dm}^3$

Fe_2O_3 , Haematite produces the largest volume of carbon dioxide gas per kilogram of the ore.

b i Limestone and coke

- ii Iron produced in the blast furnace may react with steam to form iron(III) oxide and hydrogen gas. The gas could cause explosion.

- iii Calcium carbonate is decomposed into calcium oxide and carbon dioxide. Calcium oxide which is basic, will react with acidic silicon dioxide found in sand to form calcium silicate, slag.

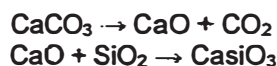

- iv Hot air introduced at the base has 78% nitrogen which goes through the furnace without reacting.

OR

B9 a Number of moles of gaseous reactants = 3 mol

Number of moles of gases products = 5 mol

There are 2 extra moles of gases after the reaction and the larger volume of gas will propel the rocket.

- b Mr of $\text{H}_2\text{O}_2 = 2 + 32 = 34$
No of mol of $\text{H}_2\text{O}_2 = 12\,000 / 34 = 353 \text{ mol}$
Energy produced = $353 / 2 \times 843 = 149\,765 \text{ kJ}$

c

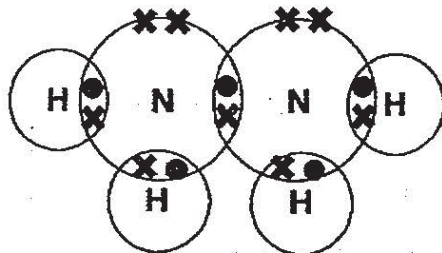

- d In the liquid state, particles are close together and in the gaseous state, the particles are far apart. Storage of the liquid will save a lot of space,

- e The energy taken in to break the bonds in 1 mol of N_2H_4 and 2 mols of H_2O_2 is less than the energy given to make the bonds in 1 mol of N_2 and 4 mols of H_2O .

Or

The energy taken in to break 4 moles of N-H bonds, 1 mole of N-N bonds, 2 moles of O-O bonds, 4 moles of O-H bonds is less than the energy released in forming 1 mole of N≡N bonds and 8 moles of O-H bonds