

Visit

FreeTestPaper.com

for more papers

Name: _____ ()

Class: _____

SECONDARY 4 O LEVEL
PRELIMINARY EXAMINATION 2016

CHEMISTRY 5073

Paper 1

31 August 2016

1 hour

READ THESE INSTRUCTIONS FIRST

Write your name, register number, and class on the OAS sheet using a **soft pencil**.

There are **forty** questions in this paper.

Answer **all** questions.

For each question there are four possible answers **A, B, C** and **D**.

Choose the correct answer and record the corresponding letter using a **soft pencil** on the OAS sheet. Amendments may be done using a soft eraser.

Each correct answer will score one mark. A mark will not be deducted for a wrong answer. A calculator may be used.

A copy of Periodic Table is provided on page 2.

The number of marks is given in brackets [] at the end of each question or part question.

The total number of marks for this paper is 40.

For Examiner's Use	
Total (40)	

This document consists of **16** printed pages.



圣尼各拉女校
CHIJ ST. NICHOLAS GIRLS' SCHOOL

Girls of Grace • Women of Strength • Leaders with Heart

[Turn over

The Periodic Table of the Elements

		Group																																																																																												
I	II	III	IV	V	VI	VII	0																																																																																							
7 Li lithium 3	9 Be beryllium 4	11 Na sodium 11	12 Mg magnesium 12	13 Al aluminium 13	14 Si silicon 14	15 P phosphorus 15	16 S sulfur 16	17 Cl chlorine 17	18 Ar argon 18	19 K potassium 19	20 Ca calcium 20	21 Sc scandium 21	22 Ti titanium 22	23 V vanadium 23	24 Cr chromium 24	25 Mn manganese 25	26 Fe iron 26	27 Co cobalt 27	28 Ni nickel 28	29 Cu copper 29	30 Zn zinc 30	31 Ga gallium 31	32 Ge germanium 32	33 As arsenic 33	34 Se selenium 34	35 Br bromine 35	36 Kr krypton 36	37 Rb rubidium 37	38 Sr strontium 38	39 Y yttrium 39	40 Zr zirconium 40	41 Nb niobium 41	42 Mo molybdenum 42	43 Tc technetium 43	44 Ru ruthenium 44	45 Rh rhodium 45	46 Pd palladium 46	47 Ag silver 47	48 Cd cadmium 48	49 In indium 49	50 Sn tin 50	51 Sb antimony 51	52 Te tellurium 52	53 I iodine 53	54 Xe xenon 54	55 Cs caesium 55	56 Ba barium 56	57 La lanthanum 57	58 Ce cerium 58	59 Pr praseodymium 59	60 Nd neodymium 60	61 Pm promethium 61	62 Sm samarium 62	63 Eu europium 63	64 Gd gadolinium 64	65 Tb terbium 65	66 Dy dysprosium 66	67 Ho holmium 67	68 Er erbium 68	69 Tm thulium 69	70 Yb ytterbium 70	71 Lu lutetium 71	72 Hf hafnium 72	73 Ta tantalum 73	74 W tungsten 74	75 Re rhenium 75	76 Os osmium 76	77 Ir iridium 77	78 Pt platinum 78	79 Au gold 79	80 Hg mercury 80	81 Tl thallium 81	82 Pb lead 82	83 Bi bismuth 83	84 Po polonium 84	85 At astatine 85	86 Rn radon 86	87 Fr francium 87	88 Ra radium 88	89 Ac actinium 89	90 Th thorium 90	91 Pa protactinium 91	92 U uranium 92	93 Np neptunium 93	94 Pu plutonium 94	95 Am americium 95	96 Cm curium 96	97 Bk berkelium 97	98 Cf californium 98	99 Es einsteinium 99	100 Fm fermium 100	101 Md mendelevium 101	102 No nobelium 102	103 Lr lawrencium 103

*58-71 Lanthanoid series
†90-103 Actinoid series

Key

a	X
b	

a = relative atomic mass
X = atomic symbol
b = proton (atomic) number

- 1 An excess of aqueous sodium hydroxide was added to a sample of ammonium sulfate crystals. The mixture was then heated gently, and the gas evolved was dried and collected using a suitable method.

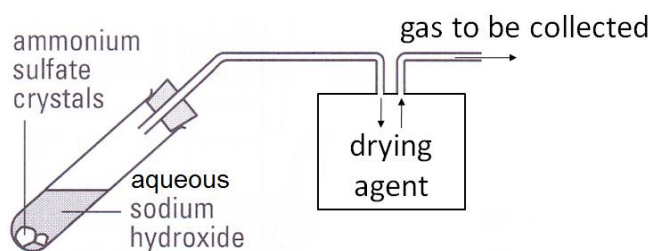

What is the most suitable drying agent and gas collection method for the gas evolved?

	Drying agent	Gas collection method
A	Anhydrous calcium chloride	Water displacement
B	Concentrated sulfuric acid	Downward delivery
C	Anhydrous calcium chloride	Upward delivery
D	Concentrated sulfuric acid	Upward delivery

- 2 The diagram below shows the partial set-up of a simple distillation experiment used to separate two substances, **X** (boiling point of 70°C) and **Y** which is soluble in **X** (boiling point of 535°C).

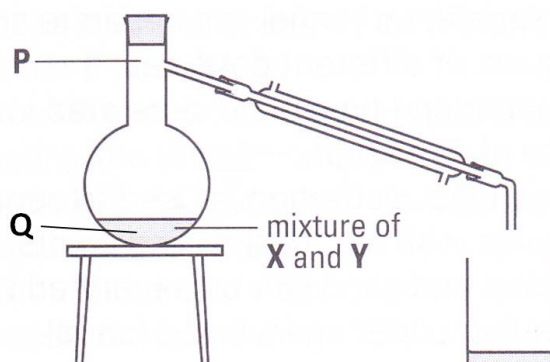

At which position, **P** or **Q**, should the bulb of a thermometer be placed at and what temperature should the thermometer show when the first distillate is collected.

- A** At **P** and at 70°C
B At **P** and at 535°C
C At **Q** and at 70°C
D At **Q** and at 535°C

- 3 An experiment was carried out to determine the different types of sugar present in a sample of mixture **X**.

Chromatogram **A** shows the separation of sugars using water as a solvent. Chromatogram **A** is then removed, rotated clockwise and then placed inside another solvent, ethanol. The final results are shown in chromatogram **B**.

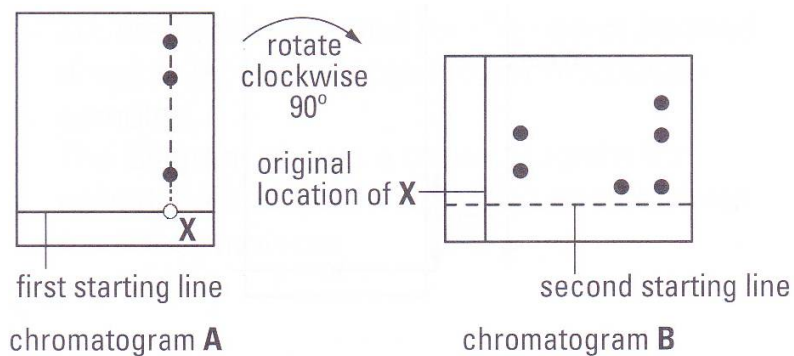

How many different types of sugars are present in mixture **X**?

- A 3
 B 4
 C 5
 D 6
- 4 The solubility curves of four different substances **A** to **D** in water are shown below:

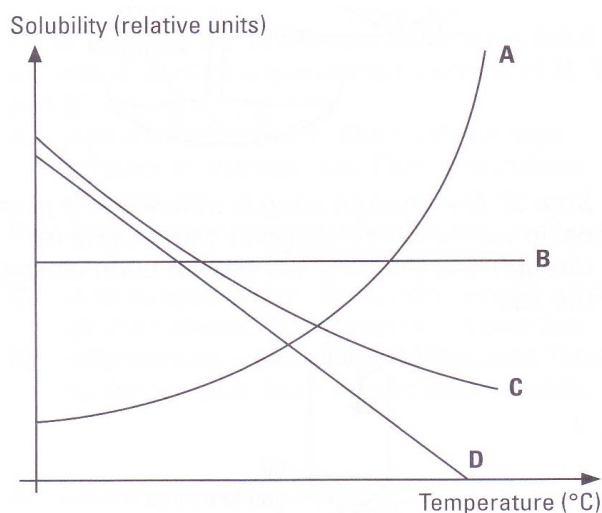

Which substance is the most suitable to be collected by crystallization from its hot saturated aqueous solution?

- 5 Which of the following best describes the arrangement of particles present in dilute aqueous ammonia?

	NH₃ molecules	OH⁻ ions
A	Not present	Close together
B	Not present	Far apart
C	Close together	Close together
D	Far apart	Far apart

- 6 The diagram below is a set up involving two gases **X** and **Y**.

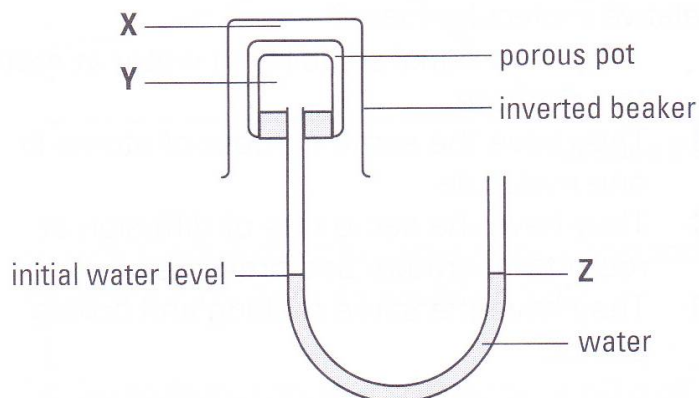

After some time, the water level at **Z** rises. What could be the identities of gas **X** and **Y**?

	X	Y
A	Fluorine	Neon
B	Ethane	Nitrogen dioxide
C	Air	Methane
D	Sulfur dioxide	Propene

- 7 The melting and boiling points of three substances are given below.

Substance	Melting point/ °C	Boiling point/ °C
Argon	-189	-186
Nitrogen	-210	-196
Oxygen	-218	-183

At what temperature would one of the above substances exist as a solid, another one as a liquid and the third as a gas?

- A** -184°C
B -188°C
C -192°C
D -214°C

8 Which of the following pairs consists of two mixtures?

- A Petrol and air
- B Sugar and bronze
- C Steel and hydrogen chloride
- D Petroleum and sulfur dioxide

9 The diagram below shows the structure of a substance.

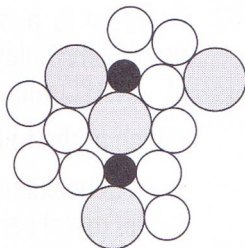

Which of the following statements about the substance is true?

- A The substance is a compound.
- B The substance melts over a range of temperature.
- C The substance has a fixed composition of its constituents.
- D The substance can be broken down into simpler forms by chemical means.

10 The following particles has different number of nucleons and electrons.

Particle	Nucleon number	Number of electrons
Atom L	26	12
Ion M²⁺	24	10

Which of the following statements about the particles is true?

- A Atoms **L** and **M** have different number of protons.
- B Atoms **L** and **M** have different number of electrons.
- C Atoms **L** and **M** have the same number of neutrons.
- D Atoms **L** and **M** have similar chemical properties, but different physical properties.

11 An imaginary element has two isotopes:

- The first has 15 protons and a relative abundance of 80%
- The second isotope has 16 neutrons.

If the relative atomic mass of the imaginary element is 30.2, determine the number of neutrons in the first isotope.

- A 15
- B 16
- C 30
- D 31

12 Study the molecule below:

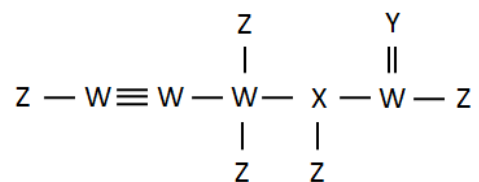

Suggest which Group of elements **W**, **X**, **Y** and **Z** could be from.

	W	X	Y	Z
A	Group III	Group V	Group VI	Group I
B	Group IV	Group III	Group VI	Group VII
C	Group III	Group V	Group II	Group I
D	Group IV	Group V	Group VI	Group VII

13 Answer questions 13 and 14 using the diagram below.

Carbon can form different structures as shown:

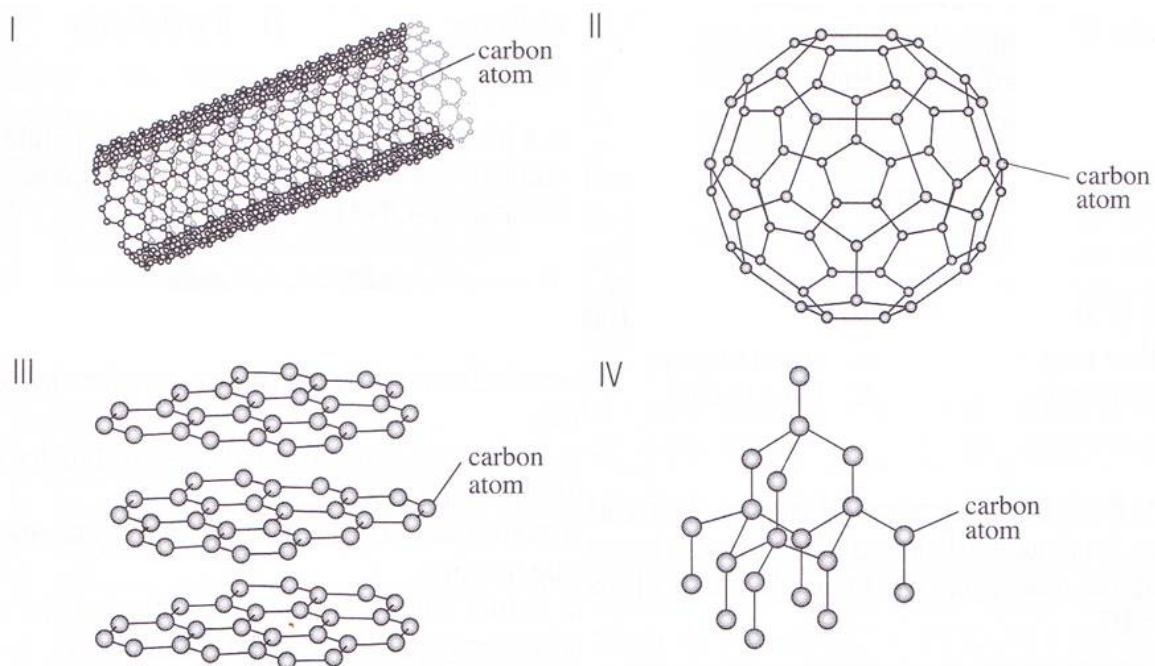

Which structure(s) is/are likely to be electrical conductors?

- A** III only
- B** I and III only
- C** I, II and IV only
- D** I, II, and III only

- 14 Using the diagram on question 13, identify which structure(s) has/have a simple covalent structure.
- A II only
 - B I and II only
 - C I, II and III only
 - D None of the above

- 15 The table below gives some information on four substances

Substance	Melting point /°C	Boiling point /°C	Electrical conductivity		Solubility in water
			As solid	As liquid	
W	17	118	Poor	Poor	Soluble
X	455	1547	Poor	Good	Insoluble
Y	1064	2970	Good	Good	Insoluble
Z	3550	4830	Poor	Poor	Insoluble

Which of the following statements is likely to be true?

- A **W** has a simple covalent structure.
 - B **X** has a giant metallic structure.
 - C **Y** is a polymer.
 - D **Z** is held together by electrostatic forces between oppositely charged ions.
- 16 Which of the following substances contains the largest number of atoms at room temperature and pressure?
- A 72 dm³ of argon
 - B 2 moles of bromine
 - C 24 g of carbon
 - D 3 x 10²³ carbon dioxide
- 17 The percentage composition of hydrogen in a hydrocarbon is 11.1%. If 1 mole of the hydrocarbon combusts completely to form 3 moles of water, what could be the relative mass of the compound?
- A 14
 - B 27
 - C 54
 - D 56

18 3.0 g of impure magnesium is added to 150 cm³ of 2.0 mol/dm³ dilute hydrochloric acid. What is the percentage purity of magnesium if only 2.4 dm³ of hydrogen gas was produced at the end of the reaction.

- A 40.0%
- B 62.5%
- C 80.0%
- D 83.3%

19 Which of the following statements about Group I metals is **incorrect**?

- A Reactivity increases down the group.
- B Melting point decreases down the group.
- C All Group I metals can react with cold water and the resultant solution turns red litmus paper blue.
- D When Group I metals are exposed to air, they react to form a grey metal oxide that is insoluble in water.

20 Which graph correctly describes a trend down Group VII?

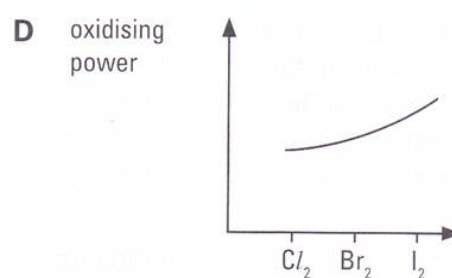
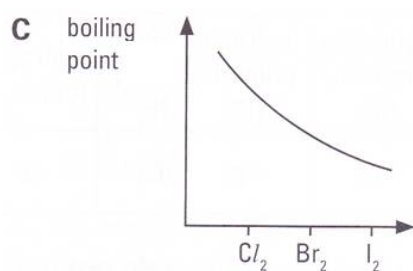
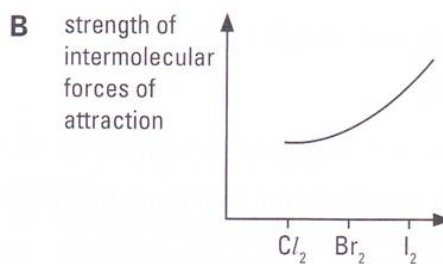
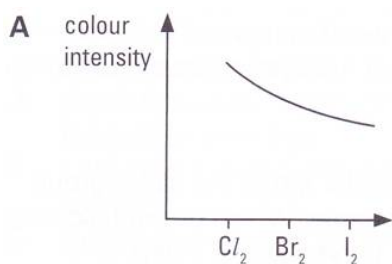

- 21 Vapour **X** was passed through a tube containing a cotton plug saturated with aqueous sodium bromide. The tube was warmed gently. The gas **Y** leaving the tube was then bubbled into **Z**.

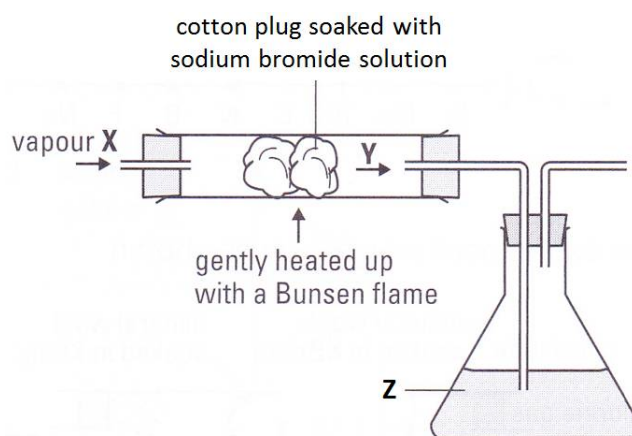

What are the possible identities of substance **X** and **Z**, with the correct corresponding observations?

	X	Z	Observation
A	Fluorine	Liquid hexene	Brown vapour Y decolourised when in contact with Z
B	Chlorine	Aqueous potassium iodide	No colour change at Z
C	Iodine	Liquid octene	Brown vapour decolourised when in contact with Z
D	Iodine	Aqueous potassium chloride	Z turned greenish-yellow

- 22 A substance NaXO_4 undergo a chemical reaction with hydrogen peroxide, according to the following equation:

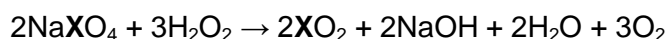

What is the role of hydrogen peroxide in the above reaction?

- A** It acts as a catalyst.
B It is a reducing agent.
C It is an oxidizing agent.
D It is a dehydrating agent.
- 23 When acidified aqueous potassium iodide is added to iron(III) sulfate solution, what will be observed?
- A** No visible change.
B Pale yellow solution turns brown.
C Pale green solution turns brown.
D Pale yellow solution turns pale green.

24 Which of the following statements about strong and weak acids is true?

- A There are no mobile OH^- ions present in all types of aqueous acids.
- B A weak dibasic acid will always have a faster rate of reaction as compared to a strong monobasic acid of the same concentration.
- C For the same basicity and concentration, weak acids have a lower pH than strong acids.
- D Regardless of strength, monobasic acids of the same concentration and volume require the same number of moles of aqueous sodium hydroxide for complete neutralization.

25 The chart below shows the colours of three indicators at different pH values:

Indicator	Colour change Low pH \rightarrow high pH	pH which colour change takes place
Methyl orange	Red \rightarrow yellow	4.0
Bromothymol blue	Yellow \rightarrow blue	6.5
Phenolphthalein	Colourless \rightarrow pink	9.0

Titration is carried out between aqueous sodium hydroxide and dilute hydrochloric acid. The pH change is plotted onto the graph shown below.

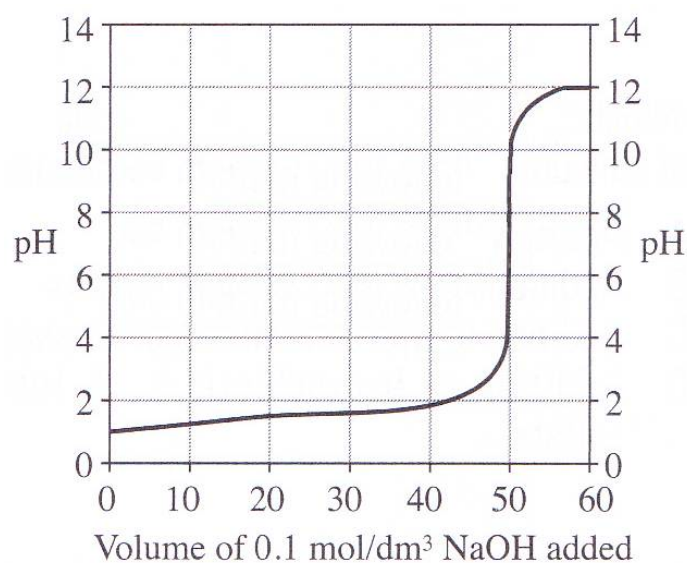

Which indicator(s) can be used to identify the end point of this titration?

- A Methyl orange only
- B Bromothymol blue only
- C Bromothymol blue and phenolphthalein only
- D Methyl orange, bromothymol blue and phenolphthalein

26 Which of the following salts can be prepared using the same method?

- A Zinc chloride, calcium sulfate
- B Potassium iodide, lead(II) iodide
- C Copper(II) sulfate, lead(II) nitrate
- D Ammonium chloride, magnesium nitrate

27 When aqueous lead(II) nitrate was added into an unknown solution, a white precipitate was formed. Subsequently, dilute nitric acid was added dropwise to the resultant mixture, till in excess. Effervescence was observed and the white precipitate dissolved completely.

Based on the observations, suggest what could be present in the unknown solution.

- A Zinc chloride
- B Ammonium iodide
- C Aluminium sulfate
- D Sodium carbonate

28 In experiment 1, one mole of ethane undergoes complete combustion to form carbon dioxide and water only. In experiment 2, one mole of butane is combusted completely instead. How will the activation energy and enthalpy change of experiment 2 be different from experiment 1?

	Activation energy	Enthalpy change
A	Unchanged	Unchanged
B	Increase	Unchanged
C	Unchanged	Increase
D	Increase	Increase

29 0.0100 mol of zinc powder is added to 100 cm³ of 0.100 mol/dm³ dilute hydrochloric acid at 25°C. The volume of gas produced is plotted against time as shown by **Graph X** below.

The experiment is then repeated using 0.0100 mol of **granulated** zinc with 100 cm³ of 0.200 mol/dm³ dilute hydrochloric acid at 50°C.

Which of the following graphs could be obtained for the second experiment?

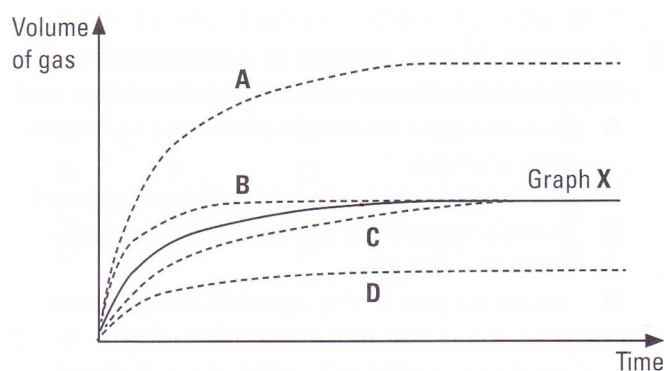

30 Which gases can be removed by factories using moist calcium carbonate?

- A NO, NO₂, SO₂
- B HCl, NO, CH₄
- C CO, NO₂, CH₄
- D HCl, NO₂, SO₂

31 The table below provides information on the chemical properties of four metals and some of their compounds.

Metal	Metal + Steam	Metal oxide + Coke	Metal carbonate heated strongly
W	H ₂ gas evolved	Oxide reduced	CO ₂ evolved
X	H ₂ gas evolved	No visible change	No visible change
Y	No visible change	Oxide reduced	CO ₂ evolved
Z	H ₂ gas evolved	No visible change	CO ₂ evolved

Which of the following shows the correct order of reactivity of the metals?

	Most reactive		→	least reactive	
A	Y	W		Z	X
B	X	Z		W	Y
C	Z	X		W	Y
D	W	X		Y	Z

32 An unknown gas X is passed over heated solid Y, as shown below.

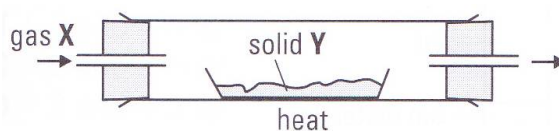

Which of the following pairs of reactants will undergo a reaction?

	Gas X	Solid Y
A	Carbon monoxide	magnesium oxide
B	Carbon dioxide	Zinc oxide
C	Hydrogen	Iron(III) oxide
D	Steam	Lead

33 Three metals were added into three aqueous salts as shown.

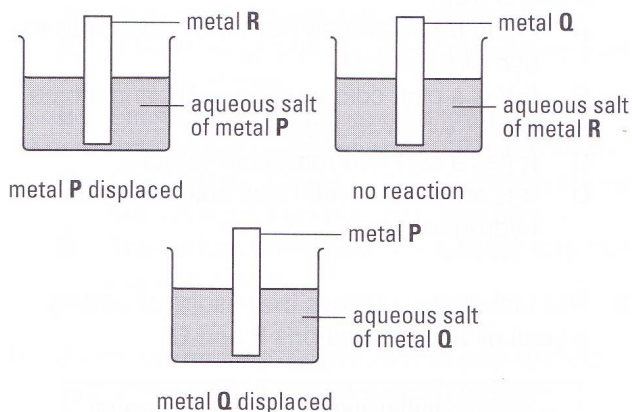

Which one of the following gives the correct order of metal reactivity?

	Least reactive	→	Most reactive
A	P		R
B	P		Q
C	Q		R
D	Q		P

34 Four iron nails are placed in separate test tubes and subjected to different conditions as shown below.

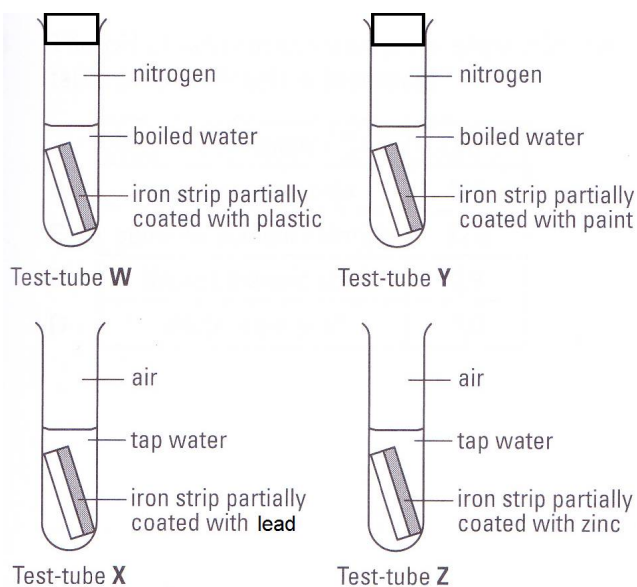

After some time, which of the above iron nails will rust?

- A** X only
- B** Z only
- C** X and Z only
- D** W and X only

- 35 Four experimental set ups are shown below. Which set up will produce bubbles of colourless, odourless gas around the copper electrode?

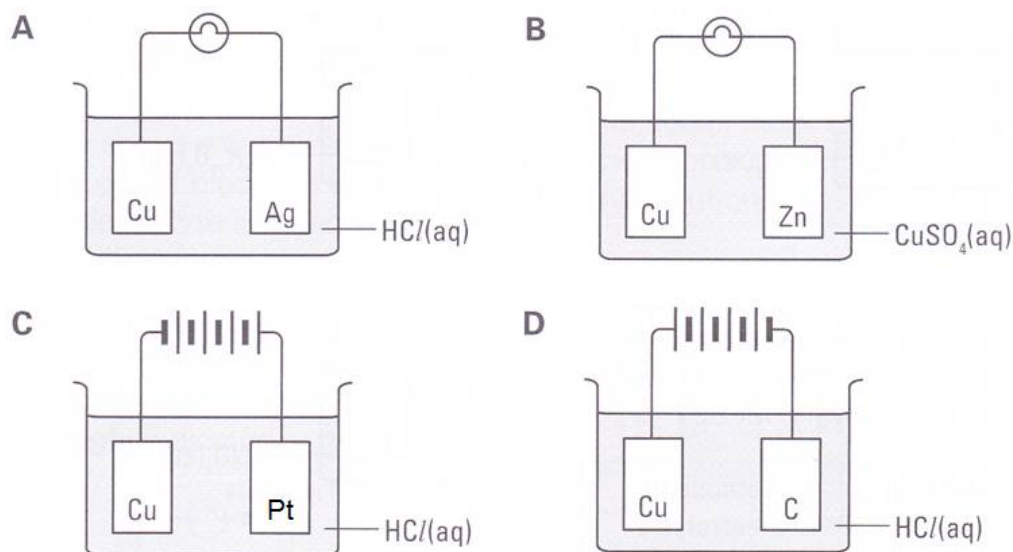

- 36 Four electrolytic cells are shown below. After a short period of time, which set up will the pH of electrolyte decreases the most significantly?

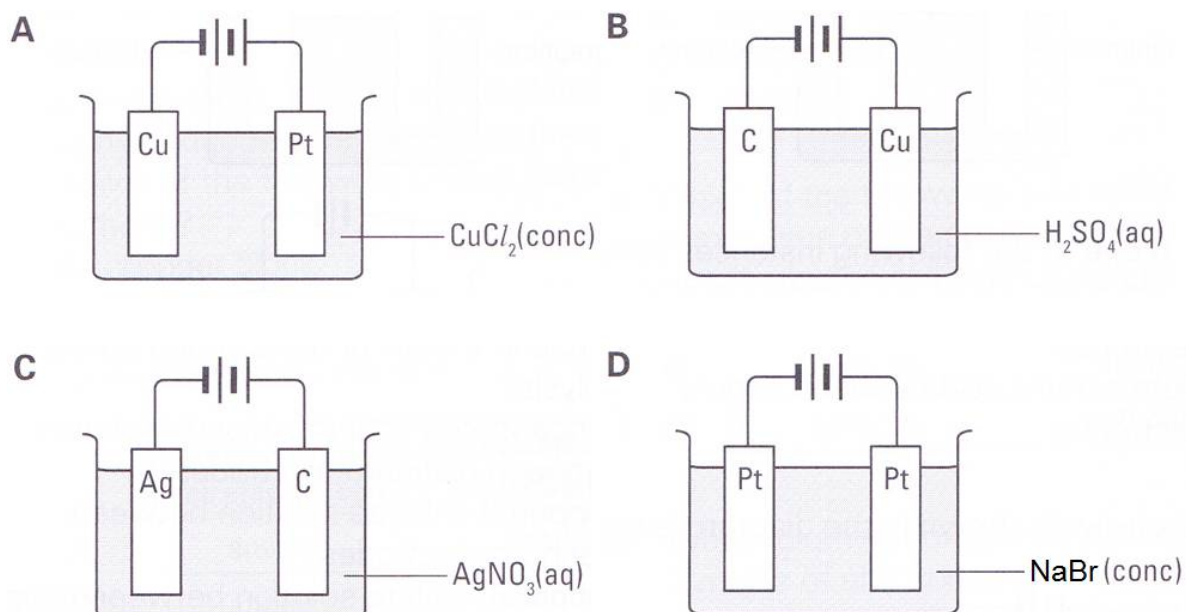

- 37 Which of the following statements describing naphtha and lubricating oil is true?

- A** Naphtha is more flammable than lubricating oil.
- B** Both naphtha and lubricating oil have sharp boiling points.
- C** Naphtha consists of larger hydrocarbons than lubricating oil.
- D** Naphtha is obtained below lubricating oil in a fractionating column.

38 The structures of molecules **X** and **Y** are shown below.

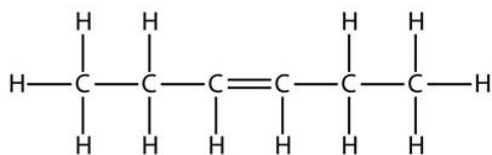
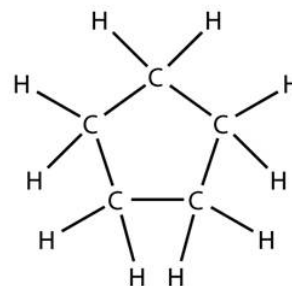
Molecule **X**Molecule **Y**

Which of the following statements about the two molecules is true?

- A** They are isomers of each other.
- B** They have different empirical formula.
- C** They have the same percentage composition.
- D** They are from the same homologous series since their general formula is the same.

39 The labels on the containers of substances **X** and **Y** have been mixed up.

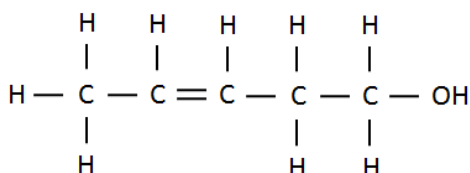
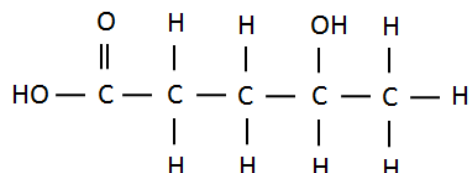
Substance **X**Substance **Y**

Which chemical test can be used to distinguish between substances **X** and **Y**?

- A** Adding copper metal
- B** Aqueous sodium carbonate
- C** Bromine under ultraviolet light
- D** Warm acidified potassium manganate(VII) solution

40 The diagram below shows an organic molecule.

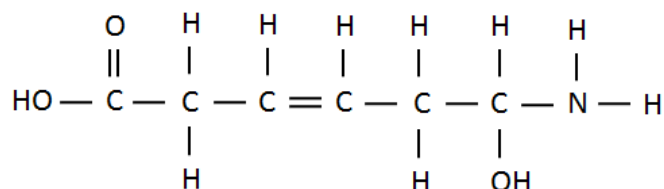

How many different types of polymer can be formed using the monomer above?

- A** None
- B** One
- C** Two
- D** Three

Answers to Section A: Circle the most appropriate answer to each question.

1	C	11	A
2	A	12	D
3	D	13	D
4	A	14	A
5	D	15	A
6	B	16	B
7	C	17	C
8	A	18	C
9	B	19	D
10	D	20	B
21	A	31	B
22	B	32	C
23	B	33	C
24	D	34	A
25	D	35	C
26	C	36	C
27	D	37	A
28	D	38	C
29	A	39	B
30	D	40	D

Name: _____ ()

Class: _____

SECONDARY 4 O LEVEL
PRELIMINARY EXAMINATION 2016

CHEMISTRY 5073

Paper 2

22 August 2016

1 hour 45 minutes

READ THESE INSTRUCTIONS FIRST

Write your name, register number, and class on all the work you hand in.
Write in dark blue or black pen.
You may use a soft pencil for any diagrams or graphs.
Do not use highlighters, glue, correction fluid or correction tape.

Answer **all** questions.

Write all answers in the answer space provided.

If working is needed for any question it must be shown with the answer.

Give non-exact numerical answers correct to 3 significant figures unless a different level of accuracy is specified in the question.

The use of a scientific calculator is expected, where appropriate.

You are reminded of the need for clear presentation in your answers.

A copy of Periodic Table is provided on page 2.

The number of marks is given in brackets [] at the end of each question or part question.

The total number of marks for this paper is 80.

For Examiner's Use	
Section A (50)	
Section B (30)	
Total (80)	

This document consists of **19** printed pages.



圣尼各拉女校
CHIJ ST. NICHOLAS GIRLS' SCHOOL

Girls of Grace • Women of Strength • Leaders with Heart

[Turn over

The Periodic Table of the Elements

		Group																																																																																												
I	II	III	IV	V	VI	VII	0																																																																																							
7 Li lithium 3	9 Be beryllium 4	11 Na sodium 11	12 Mg magnesium 12	13 Al aluminium 13	14 Si silicon 14	15 P phosphorus 15	16 S sulfur 16	17 Cl chlorine 17	18 Ar argon 18	19 K potassium 19	20 Ca calcium 20	21 Sc scandium 21	22 Ti titanium 22	23 V vanadium 23	24 Cr chromium 24	25 Mn manganese 25	26 Fe iron 26	27 Co cobalt 27	28 Ni nickel 28	29 Cu copper 29	30 Zn zinc 30	31 Ga gallium 31	32 Ge germanium 32	33 As arsenic 33	34 Se selenium 34	35 Br bromine 35	36 Kr krypton 36	37 Rb rubidium 37	38 Sr strontium 38	39 Y yttrium 39	40 Zr zirconium 40	41 Nb niobium 41	42 Mo molybdenum 42	43 Tc technetium 43	44 Ru ruthenium 44	45 Rh rhodium 45	46 Pd palladium 46	47 Ag silver 47	48 Cd cadmium 48	49 In indium 49	50 Sn tin 50	51 Sb antimony 51	52 Te tellurium 52	53 I iodine 53	54 Xe xenon 54	55 Cs caesium 55	56 Ba barium 56	57 La lanthanum 57	58 Ce cerium 58	59 Pr praseodymium 59	60 Nd neodymium 60	61 Pm promethium 61	62 Sm samarium 62	63 Eu europium 63	64 Gd gadolinium 64	65 Tb terbium 65	66 Dy dysprosium 66	67 Ho holmium 67	68 Er erbium 68	69 Tm thulium 69	70 Yb ytterbium 70	71 Lu lutetium 71	72 Hf hafnium 72	73 Ta tantalum 73	74 W tungsten 74	75 Re rhenium 75	76 Os osmium 76	77 Ir iridium 77	78 Pt platinum 78	79 Au gold 79	80 Hg mercury 80	81 Tl thallium 81	82 Pb lead 82	83 Bi bismuth 83	84 Po polonium 84	85 At astatine 85	86 Rn radon 86	87 Fr francium 87	88 Ra radium 88	89 Ac actinium 89	90 Th thorium 90	91 Pa protactinium 91	92 U uranium 92	93 Np neptunium 93	94 Pu plutonium 94	95 Am americium 95	96 Cm curium 96	97 Bk berkelium 97	98 Cf californium 98	99 Es einsteinium 99	100 Fm fermium 100	101 Md mendelevium 101	102 No nobelium 102	103 Lr lawrencium 103

*58-71 Lanthanoid series
†90-103 Actinoid series

Key

a	X	b
a = relative atomic mass		b = proton (atomic) number

X = atomic symbol

Section A

Answer all the questions in this section in the spaces provided.

The total mark for this section is 50.

A1 The following substances have different physical properties as shown below:

Substance	Melting point/ °C	Boiling point/ °C	Solubility in water
W	-114	78	soluble
X	-6	300	insoluble
Y	801	1413	soluble
Z	Sublimes at 338°C		soluble

When these substances are mixed, physical methods of separating them may include:

filtration sublimation simple distillation fractional distillation
 chromatography separating funnel crystallisation evaporation to dryness

(a) Select from the above list, the best method(s) by which each of the following mixtures at room temperature may be separated, assuming that the components do not dissolve in each other.

You may use a method once, more than once or not at all.

(i) A mixture of **W** and **X**: _____ [1]

(ii) A mixture of **X** and **Y**: _____ [1]

(iii) A mixture of **Y** and **Z**: _____ [1]

(iv) A mixture of **W**, **X** and **water**: _____ [2]

1. _____

2. _____

- (b) Chromatography is used by 'Horse Racing Forensic Laboratory' to test for the presence of illegal drugs in racehorses.

Concentrated samples of urine from racehorses are spotted onto chromatography paper on the start line. Alongside this, two known illegal drugs such as winstrol and demorphin are spotted. The chromatogram is run using **methanol** as the solvent. When finished, the chromatogram is analysed by placing under ultra-violet light.

A chromatogram of urine from four racehorses is shown below:

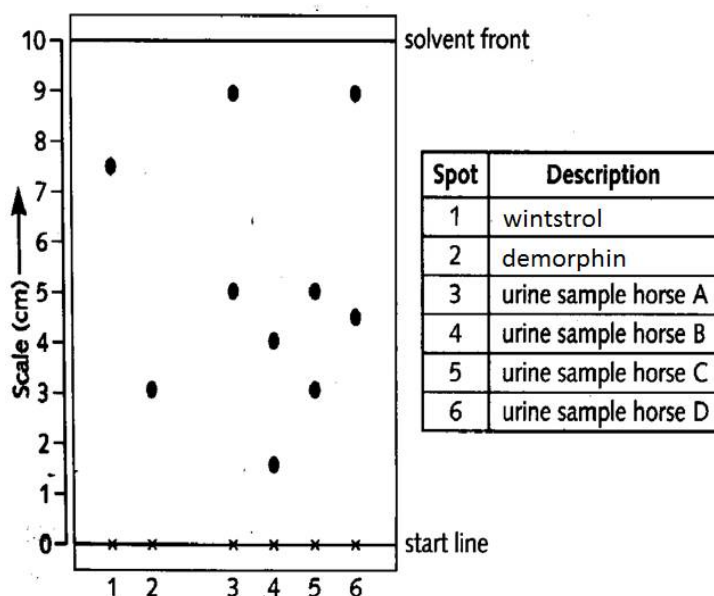

- (i) Calculate the R_f value of winstrol? [1]

- (ii) Will the R_f value of winstrol change if water, instead of methanol, was used as the solvent? Explain your answer. [1]

- (iii) State which horse was fed an illegal drug and name the drug used. [1]

- (iv) What is the purpose of ultra-violet light, when used to analyse the chromatogram? [1]

[9 Marks]

A2 Tin is a Group IV element. At room temperature, tin has a silvery white appearance and can conduct electricity. When cooled to low temperatures, the appearance of tin turns grey and the structure of tin transforms into one that resembles diamond.

- (a) In terms of bonding and structure, briefly explain why tin can conduct electricity at room temperature. [2]

- (b) State whether tin can conduct electricity at low temperatures. Explain your answer using bonding and structure. [2]

- (c) (i) Silicon is above tin in the Periodic Table. Silicon only has a structure similar to diamond and it reacts with oxygen to form silicon(IV) oxide, which is acidic in nature. [1]

Tin can also react with oxygen to form tin(IV) oxide. The tin(IV) oxide formed can undergo two reactions as shown below:

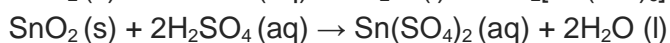
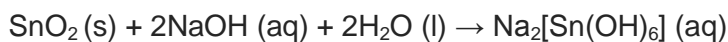

Suggest the nature of tin(IV) oxide.

- (ii) Hence, describe the trend of one chemical property for Group IV elements down the group. [1]

- (d) Describe the procedures required to obtain pure, dry silicon(IV) oxide from a mixture of silicon(IV) oxide and tin(IV) oxide. [3]

[9 Marks]

- A3** The strength of an acid can be indicated by its dissociation constant. The larger the dissociation constant value, the stronger the acid. The dissociation constant for some acids are given below.

Type of Acid	Acid	Dissociation constant, K_a
Inorganic	Hydrochloric acid, HCl	1.3×10^6
	Nitric acid, HNO_3	2.5×10^1
Organic	Methanoic acid, HCOOH	1.8×10^{-4}
	Ethanoic acid, CH_3COOH	1.75×10^{-5}
	Propanoic acid $\text{C}_2\text{H}_5\text{COOH}$	1.34×10^{-5}
	Oxalic acid, HOOC COOH	5.9×10^{-2}

- (a) (i) Using the table above, compare and comment on the general difference in the dissociation constants of organic and inorganic acids. Explain the difference in values with reference to the extent of dissociation. [2]

- (ii) Referring to the K_a values of methanoic acid, ethanoic acid and propanoic acid, describe the trend in strength within the carboxylic acid homologous series. [2]

- (b) Excess magnesium was added to 100 cm^3 of 1 mol/dm^3 aqueous methanoic acid. The time taken for the metal to produce hydrogen gas was measured and a graph was plotted as shown below.

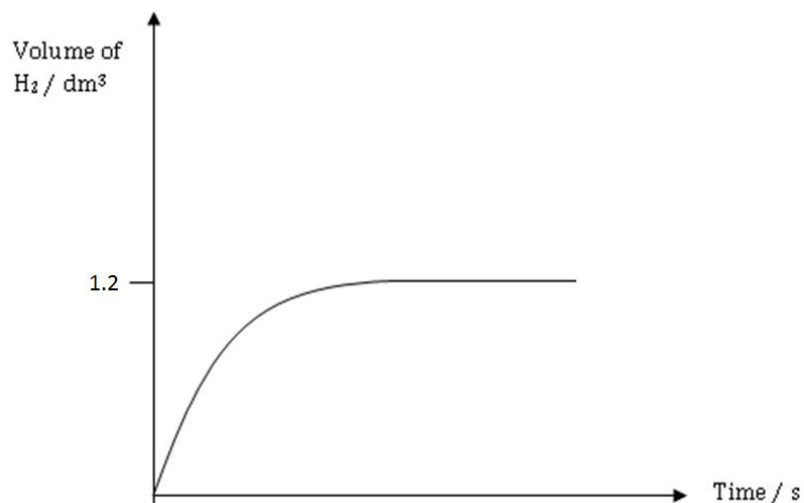

This experiment was then repeated using different dilute acids, but **keeping all the other conditions the same**.

- (i) On the same diagram, sketch a graph of the reaction when propanoic acid is used. Label this graph as **A**. [2]
- (ii) On the same diagram, sketch another graph of the reaction using nitric acid. Label this graph as **B**. [2]
- (iii) On the same diagram, sketch another graph of the reaction using oxalic acid. Label this graph as **C**. [2]
- (iv) Another student carried out the experiment with magnesium and oxalic acid dissolved in methylbenzene. Write down the observation. Explain your answer. [2]

[12 Marks]

A4 a The flow chart below shows a series of chemical tests involving substances **A** to **E**.

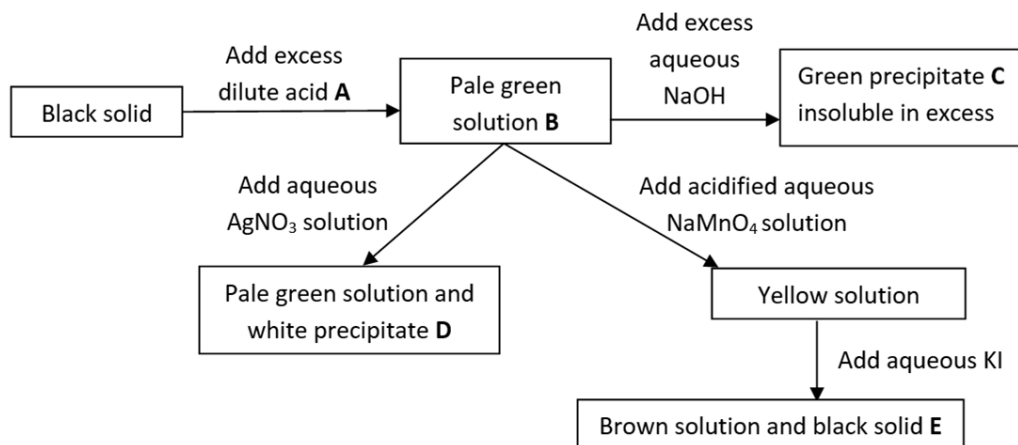

Give the chemical formula of substances **A** to **E**.

[5]

A:

B:

C:

D:

E:

b Write down the ionic equation for the formation of precipitate **C**.

[1]

[6 Marks]

A5 a When 3.10 g of copper(II) carbonate is added to 100 cm³ of 49.0 g/dm³ dilute sulfuric acid, calculate the maximum volume of carbon dioxide that can be produced, measured at room temperature and pressure. [2]

- b** If only 400 cm^3 of carbon dioxide is obtained from the reaction in part **a**, what is the percentage yield of the reaction? [1]
- c** Using the collision theory, explain how an increase in temperature will affect the rate of reaction in part **a**. [2]

[5 Marks]

- A6 a** Pure titanium is extracted from its ore, rutile - TiO_2 . Rutile is first reacted with chlorine at 1000°C to produce titanium(IV) chloride and oxygen gas. The titanium(IV) chloride formed is then cooled and collected.

- (i)** Construct the chemical equation for the reaction above. [1]

- (ii)** Which is the oxidizing agent in the reaction above? Explain your answer using oxidation states. [2]

- b** Titanium(IV) chloride is then reacted with magnesium at 1100°C in a sealed reactor which is filled with argon gas. Titanium is then obtained at the end.

- (i)** Name the type of reaction that occurred in part **b**. [1]

- (ii)** Other than magnesium, suggest another metal which could be used in part **b**. [1]

(iii) Why is argon gas used to fill the sealed container instead of air? [2]

c Aluminium can also be added into titanium to form an alloy to increase the overall strength of the metals.

In terms of structure, explain how the addition of aluminium strengthens titanium. [2]

[9 Marks]

Section B

Answer all the **three** questions in this section.

The last question is in the form of an either/or and only one of the alternatives should be attempted.

- B7** Below shows a schematic diagram of the carbon cycle. The diagram contains environmental features such as plants, factories and oceans which contribute to the removal and release of carbon dioxide to the atmosphere. The amount of carbon dioxide removed or released are represented by numerical values on the diagram. The changes are measured in **billions of tonnes of carbon dioxide per year**.

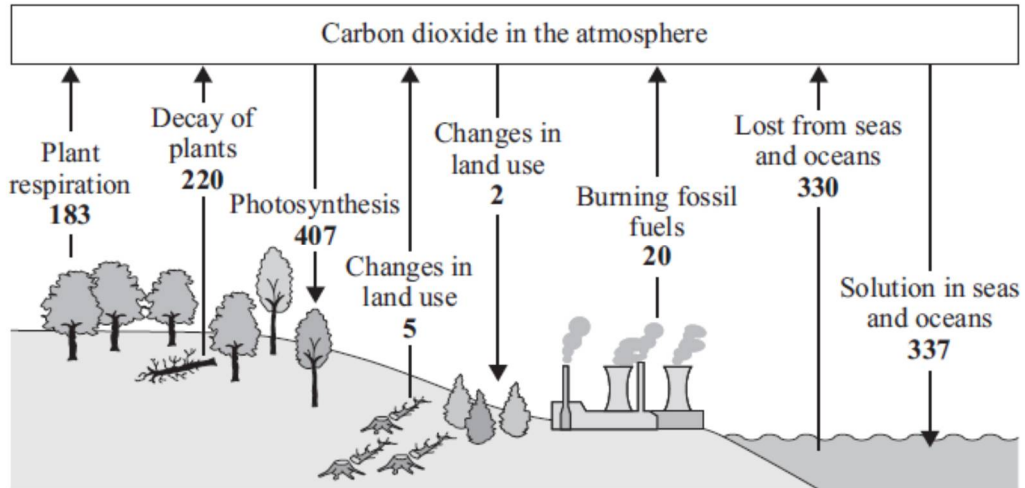

- (a) (i) Sources of carbon dioxide contributors are not only limited to the features shown above. Suggest another source of carbon dioxide emission which is **not included** in the carbon cycle diagram. [1]

- (ii) A carbon sink is an environmental feature that has a tendency to trap and store large amounts of carbon.

From the numerical data above, identify an environmental feature that is the most effective carbon sink **on land**. Explain your answer using values from the diagram. [2]

- (iii) Write a chemical equation to show how the environmental feature in part (a)(ii) trap and store carbon. [1]

(b) Ocean acidification is one of the top environmental issues today. Ocean acidification refers to a decrease in the pH of the ocean over an extended period of time.

(i) Using numerical data from the carbon cycle diagram, explain how oceans are being acidified. [2]

(ii) The burning of fossil fuels such as coal also releases another gas that contributes to ocean acidification. Name this gas. [1]

(iii) What chemical can be used by factories to remove the gas in **(b)(ii)**? [1]

(iv) Write the chemical equation for the reaction in **(b)(iii)**. [1]

(c) Many marine organisms produce calcium carbonate structures and use them as a form of shelter. Suggest how ocean acidification will affect these organisms. [1]

[10 Marks]

B8 The Haber process produces ammonia from the reaction between nitrogen and hydrogen.

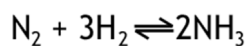

It be carried out at various temperature and pressure to obtain different yields of ammonia as shown in the graph below.

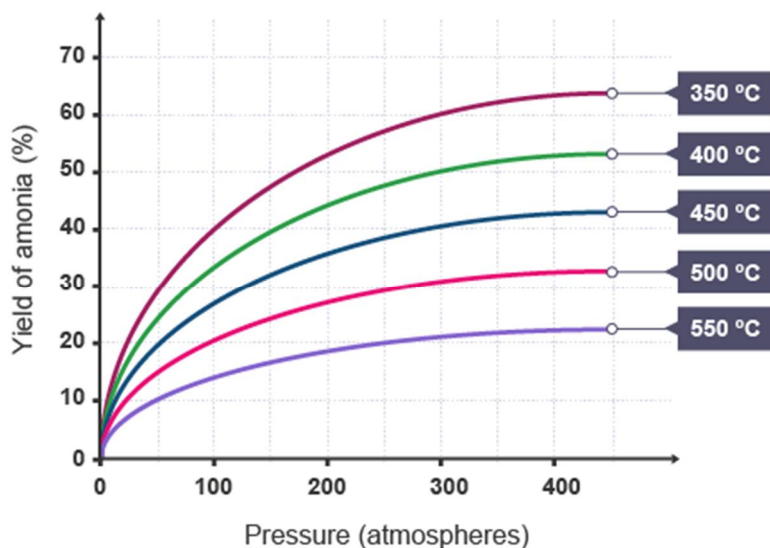

- (a) From the graph, describe the relationship between temperature, pressure and the yield of ammonia. [2]

- (b) (i) Calculate the enthalpy change for the Haber process using the bond energies given below. [2]

Type of bond	Bond energy (kJ/mol)
H-H	432
N-H	391
N-N	160
N=N	418
N≡N	941

- (ii)** From the answer in **b(i)**, explain why the reaction is exothermic or endothermic in terms of bond breaking and bond formation. [2]

- (c) (i)** State the conditions commonly used by industries to carry out the Haber process. [1]

- (ii)** With the aid of a labelled energy profile diagram, explain how a catalyst affects the rate reaction in the Haber process. [3]

[10 Marks]

EITHER

- B9** Copper extracted from the blast furnace can be further purified or refined using electrolysis. A student tried to carry out this process and set up an experiment as shown below.

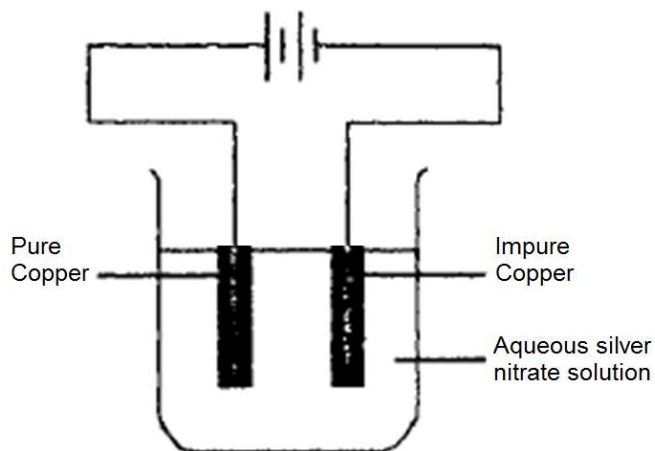

- (a) (i) The student failed to extract copper from the impure copper. State two changes [2] that have to be made to the set up above for the purification process to be carried out properly.

- (ii) If the anode in the **student's set-up** is changed to graphite, what will be [2] observed at the anode and what happens to the pH of the electrolyte after some time?

- (b) There are various forms of cells that can be used to generate electricity. Below shows the schematic diagram of a direct ethanol fuel cell (DEFC):

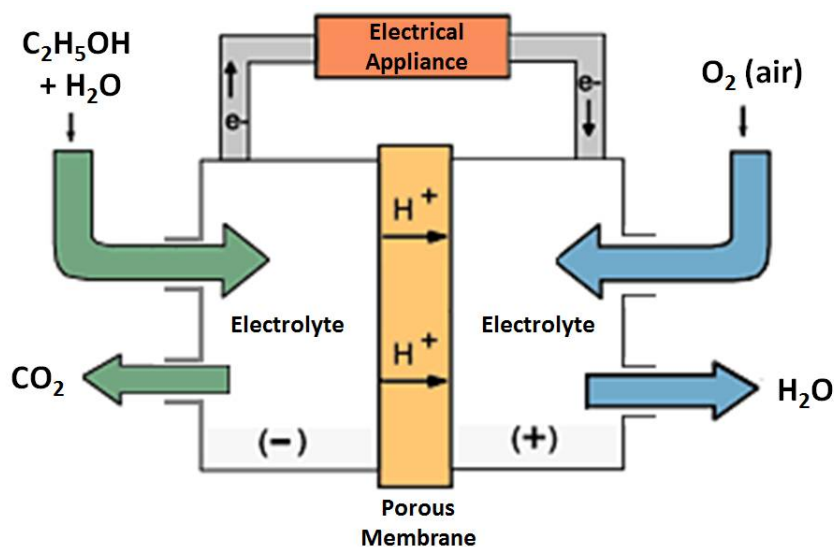

The half equation at the anode is:

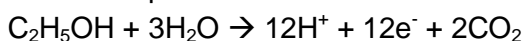

The half equation at the cathode is:

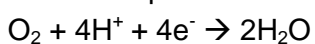

- (i) Construct the overall equation for the reaction occurring in a DEFC. [2]

- (ii) If 4.00 moles of electrons flow through the electrical appliance, what is the maximum volume of carbon dioxide gas, at room temperature and pressure, that can be produced by the DEFC? [2]

- (c) Hydrogen can also be used in a fuel cell, state one advantage and one disadvantage of using hydrogen instead of ethanol in a fuel cell. [2]

[10 Marks]

OR

B9 Vitamin A, also known as retinol, is important for eye health and vision. Retinol has the following structure:

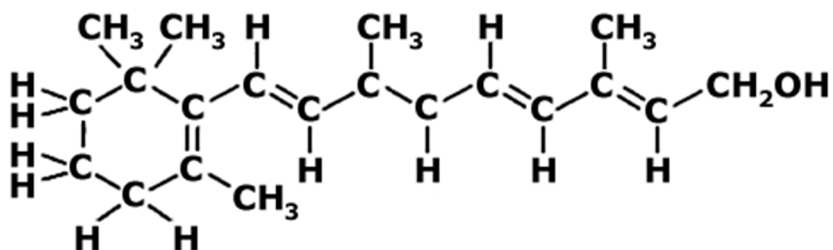

- (a) (i) How many moles of aqueous I₂ can react completely with 1 mol of Vitamin A in the dark? [1]

- (ii) Vitamin A (Retinol) is oxidized in the body to form retinoic acid, which helps to maintain skin health and bone growth.

Describe a chemical test that could be used to distinguish retinol from retinoic acid. State the corresponding observations. [2]

- (b) Organic compound **P** has the general formula C_nH_{2n} . It can undergo a series of [7] chemical reaction to form compound **Z** as shown in the chart below.

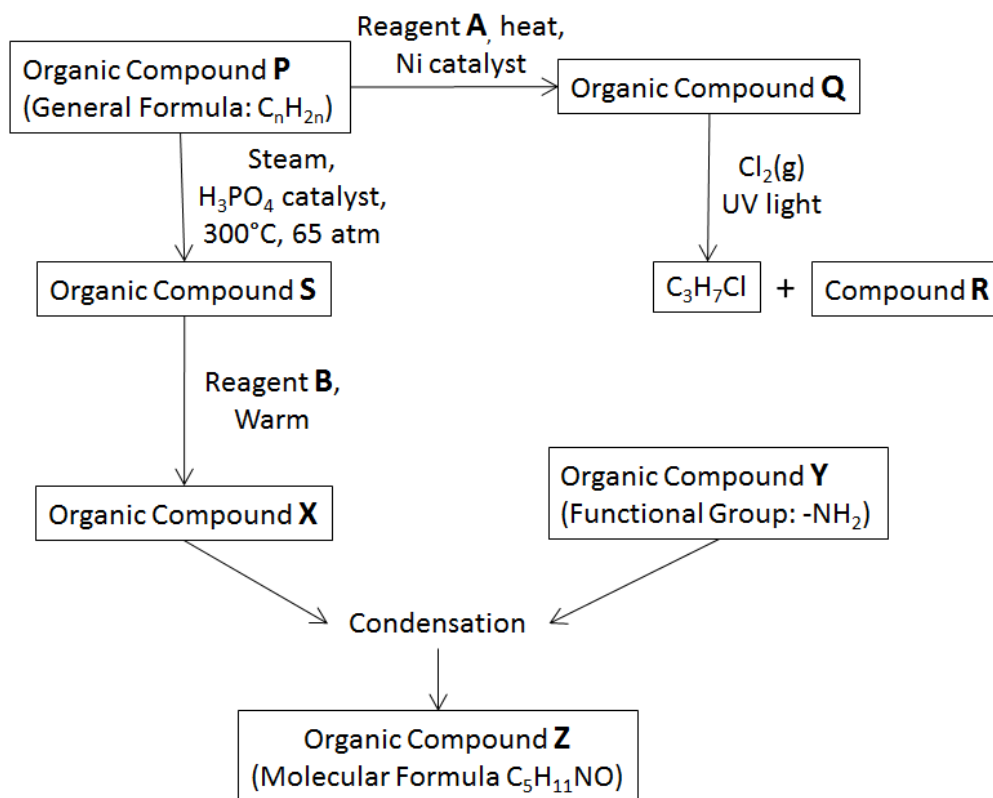

- (i) Identify and draw the full structural formulae of compounds **P**, **Q**, and **R**. [3]

P:

Q:

R:

(ii) What is reagent **A**? [1]

(iii) If compound **S** and compound **X** can react together to form a sweet smelling liquid, what is the name of reagent **B**? [1]

(iv) What is the name of the sweet smelling liquid formed from compound **S** and compound **X**? [1]

(v) Using information from the flow chart, write down the structural formula of compound **Y**. [1]

[10 Marks]

End of Paper 2

Mark scheme for Sec 4 Prelim 2016 Paper 2

Section A (50 marks)

A1	ai	Separating funnel
	aii	Filtration
	aiii	Sublimation
	aiv	1. Separating funnel, 2. Fractional distillation
	bi	0.75
	bii	Yes, X has different solubility in <u>different solvents</u> ,
	biii	Horse C / Horse 5 Dermorphin / Demorphin
	biv	To make the spots <u>visible/seen</u> . OR <u>reveal/locate or identify</u> the position of the spots.
A2	a	Tin has giant <u>metallic</u> structure/has <u>metallic</u> bonds. consists of cations in a <u>sea of delocalized electrons</u> The <u>electrons are mobile</u>
	b	Each <u>tin atom</u> uses all 4 of its <u>valence electrons</u> / <u>all valence electrons</u> used for <u>covalent bonds/bonding</u> <u>no mobile electrons</u> to conduct electricity
	ci	<u>Amphoteric</u>
	cii	Down group IV, the elements become <u>more metallic</u> in character. Down group IV, the elements turn from <u>non-metal to metal</u> . Down group IV, the elements <u>reducing property increases</u> . Down group IV, the oxides formed turn from <u>acidic to amphoteric</u> . Down group IV, the oxides formed become <u>more basic</u> .
	d	Add <u>excess</u> <u>Aq or dilute nitric acid/sulfuric acid/hydrochloric</u> <u>Filter</u> the mixture to <u>obtain the residue</u> <u>Wash</u> the residue with <u>distilled water</u> (if wash with wrong solution, do not award) <u>Dry</u> between sheets of <u>filter paper</u>
	A3	ai

		Prevents <u>Ti</u> from oxidizing back into <u>TiO₂</u> OR Prevents <u>Ti</u> from reacting with air or O ₂ OR Prevents the <u>more reactive metal</u> from reacting with air or O ₂
	c	<u>Different sized atoms</u> <u>Disrupts the regular arrangement</u> <u>Layers unable to slide over each other</u> ("layers" must be included)

Section B (30 marks)

B7	ai	Any 1 of the following: <u>Combustion of fuel in cars/aircrafts</u> <u>Animal Respiration</u> <u>Decay of dead animals</u>
	aii	Plants <u>take in 407</u> but <u>give out 183</u> and <u>220</u> billions of tonnes. OR Overall, plants absorb <u>4</u> (award 0m only if ans is 224) billions of tonnes.
	aiii	$6\text{CO}_2 + 6\text{H}_2\text{O} \rightarrow \text{C}_6\text{H}_{12}\text{O}_6 + 6\text{O}_2$ If $6\text{CO}_2 + 12\text{H}_2\text{O} \rightarrow \text{C}_6\text{H}_{12}\text{O}_6 + 6\text{O}_2 + 12\text{H}_2\text{O}$, minus 1/2m (not balanced)
	bi	Oceans <u>take in 337</u> but only <u>give out 330</u> billions of tonnes. OR Overall, oceans absorb <u>7</u> billions of tonnes. Carbon dioxide is acidic / form carbonic acid
	bii	Sulfur dioxide
	biii	CaO, Ca(OH) ₂ , CaCO ₃
	biv	CaCO ₃ + SO ₂ → CaSO ₃ + CO ₂ OR CaO + SO ₂ → CaSO ₃ OR CaCO ₃ + H ₂ SO ₃ → CaSO ₃ + CO ₂ + H ₂ O OR Ca(OH) ₂ + SO ₂ → CaSO ₃ + H ₂ O
	c	Acids can <u>react with/corrode/remove/destroy</u> the carbonate structures

B8	a	The <u>higher the temperature</u> , the <u>lower the yield</u> The <u>higher the pressure</u> , the <u>higher the yield</u>
	bi	941 + 3(432) OR (+2237) -6(391) = OR (-2346) -109 kJ/mol
	bii	The <u>energy absorbed to break bonds</u> (used or required = 0m) Is <u>less</u> than the <u>energy released to form bonds</u> (used or required = 0m) Hence, energy is given out to the surroundings/ the reaction is exothermic OR hence ΔH is negative
	ci	Iron, 400°C, 200 atm
	cii	Correctly labelled axis Correctly drawn and labelled reactants and products Correctly drawn and labelled E_a (catalyzed) and E_a (uncatalysed) Correctly drawn curves (2 curves) Provides an alternative pathway With lower activation energy
B9 Eit her	ai	Switch the polarity of the battery OR swap the positions of the electrodes Change the electrolyte to aqueous copper(II) nitrate/chloride/sulfate
	a ii	<u>Effervescence</u> is observed. pH of the electrolyte <u>decreases/</u> become <u>more acidic</u>
	bi	$C_2H_5OH + 3H_2O \rightarrow 12H^+ + 12e^- + 2CO_2$ $3O_2 + 12H^+ + 12e^- \rightarrow 6H_2O$ $C_2H_5OH + 3H_2O + 3O_2 \rightarrow 2CO_2 + 6H_2O$ $C_2H_5OH + 3O_2 \rightarrow 2CO_2 + 3H_2O$
	bii	Max no of mol of CO_2 formed = $4 / 12 \times 2 = 0.6667$ mol Max vol of CO_2 formed = $0.6667 \times 24 = 16.0$ dm ³
	c	The only product of the hydrogen fuel cell is <u>water</u> Ethanol fuel cell <u>produces CO_2</u> <u>Hydrogen gas needs to be liquefied</u>
B9 OR	ai	4 mol
	a ii	<u>Warm and acidified</u> <u>potassium manganate (VII) solution</u> will turn from <u>purple</u> to <u>colourless</u> when added to <u>retinol</u> <u>Effervescence</u> OR colourless gas <u>Water</u> when a reactive metal (must state the metal eg <u>Zn, Mg, etc</u>)

	OR <u>aqueous sodium carbonate</u> is added to <u>retinoic acid</u> .
--	---

bi

P:

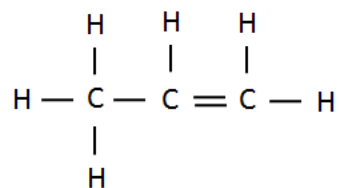

Q:

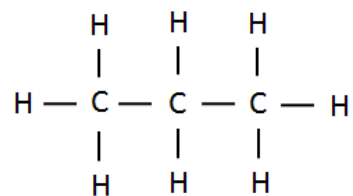

R:



bii	Hydrogen gas or H ₂
biii	Acidified Aqueous potassium manganate(VII)
biv	Propyl propanoate
bv	CH ₃ CH ₂ NH ₂ OR C ₂ H ₅ NH ₂

Name: _____ ()

Class: _____

SECONDARY FOUR
REVISION TEST 2

CHEMISTRY

12 August 2016

1 hour 10 minutes

READ THESE INSTRUCTIONS FIRST

Write your name, register number, and class on all the work you hand in.

Write in dark blue or black pen.

You may use a soft pencil for any diagrams or graphs.

Do not use highlighters, glue, correction fluid or correction tape.

Answer **all** questions.

Write all answers in the answer space provided.

If working is needed for any question it must be shown with the answer.

Give non-exact numerical answers correct to 3 significant figures unless a different level of accuracy is specified in the question.

The use of a scientific calculator is expected, where appropriate.

You are reminded of the need for clear presentation in your answers.

A copy of Periodic Table is provided on page 2.

The number of marks is given in brackets [] at the end of each question or part question.

The total number of marks for this paper is 50.

For Examiner's Use	
Section A (10)	
Section B (20)	
Section C (20)	
Total (50)	

This document consists of **13** printed pages.



圣尼各拉女校
CHIJ ST. NICHOLAS GIRLS' SCHOOL

Girls of Grace • Women of Strength • Leaders with Heart

[Turn over

The Periodic Table of the Elements

		Group																																															
I	II	III	IV	V	VI	VII						0																																					
7 Li lithium 3	9 Be beryllium 4	11 Na sodium 11	12 Mg magnesium 12	13 Al aluminium 13	14 Si silicon 14	15 P phosphorus 15	16 S sulfur 16	17 Cl chlorine 17	18 Ar argon 18						19 K potassium 19	20 Ca calcium 20	21 Sc scandium 21	22 Ti titanium 22	23 V vanadium 23	24 Cr chromium 24	25 Mn manganese 25	26 Fe iron 26	27 Co cobalt 27	28 Ni nickel 28	29 Cu copper 29	30 Zn zinc 30	31 Ga gallium 31	32 Ge germanium 32	33 As arsenic 33	34 Se selenium 34	35 Br bromine 35	36 Kr krypton 36																	
37 Rb rubidium 37	38 Sr strontium 38	39 Y yttrium 39	40 Zr zirconium 40	41 Nb niobium 41	42 Mo molybdenum 42	43 Tc technetium 43	44 Ru ruthenium 44	45 Rh rhodium 45	46 Pd palladium 46	47 Ag silver 47	48 Cd cadmium 48	49 In indium 49	50 Sn tin 50	51 Sb antimony 51	52 Te tellurium 52	53 I iodine 53	54 Xe xenon 54	55 Cs caesium 55	56 Ba barium 56	57 La lanthanum 57	58 Ce cerium 58	59 Pr praseodymium 59	60 Nd neodymium 60	61 Pm promethium 61	62 Sm samarium 62	63 Eu europium 63	64 Gd gadolinium 64	65 Tb terbium 65	66 Dy dysprosium 66	67 Ho holmium 67	68 Er erbium 68	69 Tm thulium 69	70 Yb ytterbium 70	71 Lu lutetium 71	72 Hf hafnium 72	73 Ta tantalum 73	74 W tungsten 74	75 Re rhenium 75	76 Os osmium 76	77 Ir iridium 77	78 Pt platinum 78	79 Au gold 79	80 Hg mercury 80	81 Tl thallium 81	82 Pb lead 82	83 Bi bismuth 83	84 Po polonium 84	85 At astatine 85	86 Rn radon 86
87 Fr francium 87	88 Ra radium 88	89 Ac actinium 89											89 La lanthanoid series	90 Th thorium	91 Pa protactinium	92 U uranium	93 Np neptunium	94 Pu plutonium	95 Am americium	96 Cm curium	97 Bk berkelium	98 Cf californium	99 Es einsteinium	100 Fm fermium	101 Md mendelevium	102 No nobelium	103 Lr lawrencium																						

*58-71 Lanthanoid series
†90-103 Actinoid series

Key

a	X
b	

a = relative atomic mass
X = atomic symbol
b = proton (atomic) number

Topics tested: Mole Concept, Metals, Simple Cell and Electrolysis, Separation techniques, Periodic Table, Acid, base and salt, Qualitative Analysis, Ammonia, Redox, Air

Section A: Multiple Choice Questions (10 marks)

Circle the most appropriate answer to each of the respective questions at the Answer Box on Page 6.

- 1 What is essential in the conversion of pig iron to low-carbon steel?
- A A decrease in the amount of carbon present
 - B The addition of sulfur
 - C The addition of zinc
 - D The oxidation of iron to iron(III) oxide
- 2 Which of the following solutions can be used to distinguish between sodium bromide and sodium chloride solution?
- I chlorine water
 - II bromine water
 - III dilute sodium hydroxide
 - IV dilute barium nitrate
- A I only
 - B I and II only
 - C II and IV only
 - D I and IV only
- 3 The mass of oxygen in a sample of zinc sulfate crystals $\text{ZnSO}_4 \cdot 7\text{H}_2\text{O}$ was found to be 44.0 g. Find the mass of the hydrated salt.
- A 67.2 g
 - B 71.8 g
 - C 79.4 g
 - D 105.1 g
- 4 10.0 cm^3 of 1.0 mol/dm^3 aqueous iron (III) sulfate was mixed with 10.0 cm^3 of 1.0 mol/dm^3 aqueous sodium hydroxide. What was observed when the reaction was complete?
- A A green precipitate and a colourless solution.
 - B A green precipitate and a yellow solution.
 - C A reddish brown precipitate and a yellow solution.
 - D A reddish brown precipitate and a colourless solution.

5 The circuit diagram of a simple cell is shown below.

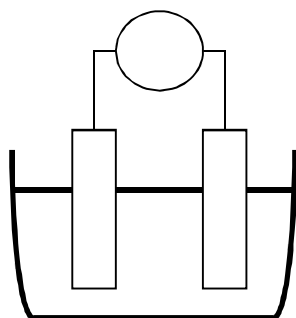

Which correct combination of electrolyte and electrodes will permit the light bulb to light up most brightly?

	Electrolyte	Electrodes
A	Aqueous sodium nitrate	Copper and iron
B	Dilute sulfuric acid	Zinc and silver
C	White crystals of lead(II)bromide	Copper and Magnesium
D	Liquid bromine	Silver and zinc

6 The diagram shows the apparatus used to obtain water from a solution of blue copper(II) sulfate.

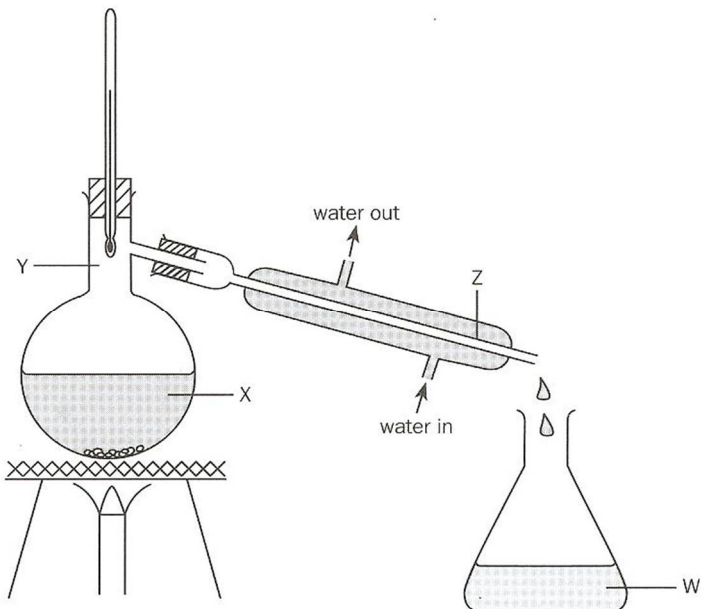

At which part of the apparatus will the temperature be greater than 100°C?

- A W
- B X
- C Y
- D Z

7 Which of the following reaction(s) will not give off a gas?

- I Heating sodium carbonate
- II Heating hydrated sodium carbonate
- III Heating of magnesium carbonate
- IV Heating ammonium nitrate with dilute hydrochloric acid

- A II and IV only
- B I and II only
- C II and III only
- D I and IV only

8 Ammonia is produced by Haber process.
Which statement about the reaction is correct?

- A Ammonia may decompose to form hydrogen and nitrogen at a certain temperature.
- B There is an increase in volumes of gases when ammonia is being formed.
- C The conditions usually used by industries include 450 atm and 200°C
- D Hydrogen gas used is obtained by fractional distillation of liquefied air.

9 Which of the following is true for the electrolytic purification of silver?

	Cathode	Anode	Type of reaction occurring at the positive electrode
A	Pure silver	Impure silver	Reduction
B	Pure silver	Impure silver	Oxidation
C	Impure silver	Pure silver	Reduction
D	Impure silver	Pure silver	Oxidation

10 A catalytic converter in a car exhaust system changes pollutants into less harmful products.

Which changes does not occur in a catalytic converter?

- A Carbon dioxide \rightarrow carbon
- B Carbon monoxide \rightarrow carbon dioxide
- C Nitrogen oxides \rightarrow nitrogen
- D Unburned hydrocarbon \rightarrow carbon dioxide + water

Answers to Section A : Circle the most appropriate answer to each question.

- | | | | | | | | | | |
|---|---|---|---|---|----|---|---|---|---|
| 1 | A | B | C | D | 6 | A | B | C | D |
| 2 | A | B | C | D | 7 | A | B | C | D |
| 3 | A | B | C | D | 8 | A | B | C | D |
| 4 | A | B | C | D | 9 | A | B | C | D |
| 5 | A | B | C | D | 10 | A | B | C | D |

Section B: Short structured Questions (20 marks)

B1 The following substances are given

propanol	silver chloride	ammonium chloride
calcium carbonate	pentanol	water

Each substance can be used once, more than once, or not at all

a) Which two substances (excluding water) when mixed together, can be separated by dissolution followed by filtration? [1]

b) Which substance can be obtained by sublimation when mixed with calcium chloride? [1]

c) Which substance is best obtained by simple distillation when mixed with ammonium chloride? [1]

d) Which two substances (excluding water) when mixed together, can be separated by fractional distillation? [1]

B2 A village in the North East of England called Quaking Houses is situated near an old coal power stations which involves the burning of fossil fuels. During the early 1990s the villagers became concerned by the pollution found in their local stream and soil. These consisted of very acidic water containing high concentrations of aluminium ions and sulfate ions which are typical products of the run-off from coal power stations.

- a) Identify the air pollutant responsible for making the soil and water acidic. [2]
Explain your reason.

- b) Calcium carbonate can be added to the fertilizer so that soil does not become acidic, but calcium hydroxide should not be used. [2]

Explain why calcium hydroxide and fertilizer should not be added to soil at the same time.

- c) A sample of acidic water is tested in the laboratory. [3]
Describe how to identify that sample contains aluminium ion and sulfate ion.

B3 In the diagram below, Cell 1 contains aqueous chromium(III) nitrate and Cell 2 contains concentrated metal **X** chloride solution. All four electrodes are made of graphite. Electrodes **Q** and **S** increase in mass during the electrolysis. 13.0 g of chromium was deposited at **Q** and 24.0 g of a metal **X** was deposited at **S**.

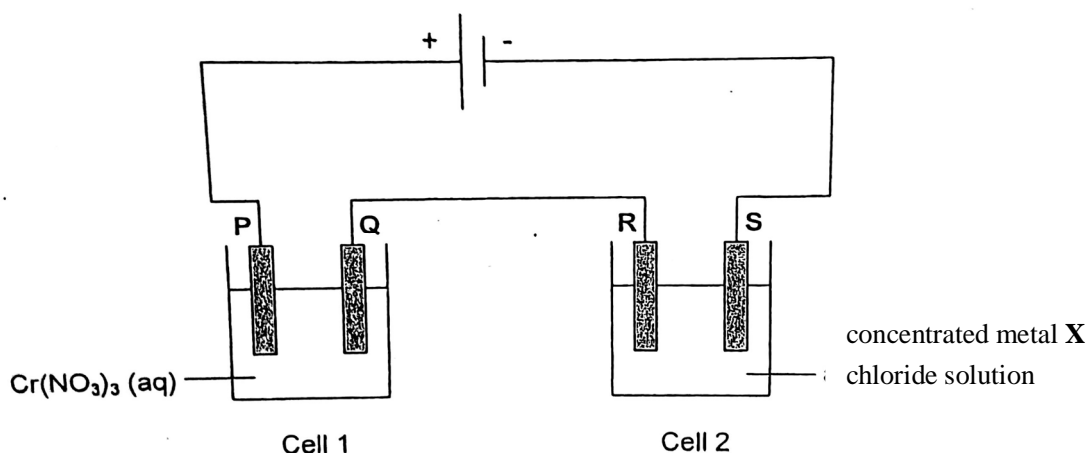

a) Write the ionic equation for the reaction taking place at anode of cell 1. [1]

b) Identify metal **X** if its ionic charge is 2+. Show your working. [3]

c) i) Explain in terms of oxidation state, what type of reaction occurs at **R**. [1]

ii) Suggest why the volume of gas collected at **R** is less than expected. [1]

d) Briefly describe how a pure dry crystals of chromium(III) nitrate can be prepared. [3]

Section C: 20 marks

C1 A pH probe attached to a computer measures pH changes during some titration experiments.

In **experiment 1**, 0.1 mol/dm^3 sodium hydroxide was added from a burette to 25.0 cm^3 of dilute hydrochloric acid.

In **experiment 2**, 0.1 mol/dm^3 sodium hydroxide was added from a burette to 25.0 cm^3 of dilute ethanoic acid.

The pH probe measured the pH during both experiments.

The graph below shows the results from experiment 1 and 2.

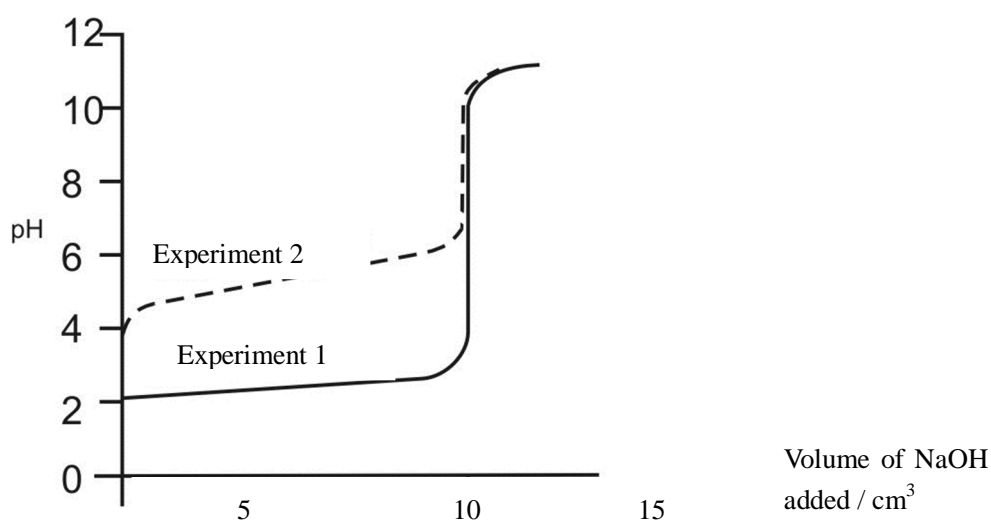

a) Use the information to calculate the concentration of dilute hydrochloric acid used in experiment 1. [2]

b) Explain on the difference in the initial pH of ethanoic acid and hydrochloric acid. [2]

c) The table below shows the colour change of various indicators. [2]

Indicator	Colour change Low pH → high pH	pH which colour change takes place
Methyl orange	Red → yellow	4.0
Bromothymol blue	Yellow → blue	6.5
Phenolphthalein	Colourless → pink	9.0

Which indicator is the most suitable to detect the end point for experiment 2. Explain your answer using the graph.

d) A third experiment was carried out. A solution of dilute hydrochloric acid of the same concentration and same volume as that used in **experiment 1** was used. This time dilute sodium hydroxide of a concentration of 0.2 mol/dm^3 was added from the burette. [2]

On the graph, sketch the shape of the graph you would expect from this experiment.

e) "Lead(II) oxide can be added to dilute hydrochloric acid to change its pH to neutral". Do you agree with this statement. Explain. [2]

C2 The table shows some data on three metals **V**, **X** and **Y**.

metal	melting point °C	boiling point °C	chemical properties
V	64	759	It reacts violently with cold water.
X	1083	2595	Its carbonate is green in colour and it decomposes to form black solid.
Y	650	1107	It reacts readily with cold water but vigorously with steam.

a) Which metal(s) is/are likely to be a transition metal. Explain your answer. [2]

b) Suggest the best methods of extracting the metals **Y** and **X** from their oxides. [2]

c) **V** is reacted with chlorine and bromine respectively in two separate reactions. [3]
Which reaction is faster? Explain your answer in terms of atomic structure of chlorine and bromine.

- d) Using **V** as the symbol, write down the chemical equation for reaction between **V** and cold water. [1]

- e) Based on the information in the table.

metal	melting point °C	boiling point °C	Chemical properties
Z	327	1750	Its carbonate decompose upon heating. Its oxide is orange when hot and yellow when cold.

- i) Identify metal **Z**. [1]

- ii) Engineers suggest that attaching a piece of **Z** to steel can help to reduce rusting of steel. Do you agree? Explain. [1]

End of paper

Mark scheme for Sec 4 RT2

Section A (10 marks)

1	2	3	4	5	6	7	8	9	10
A	A	B	C	B	B	D	A	B	A

Section B (40 marks)

B1	a	Silver chloride and ammonium chloride OR Calcium carbonate and ammonium chloride	[1]
	b	Ammonium chloride	[1]
	c	water	[1]
	d	Pentanol and propanol	[1]
B2	a	Sulfur dioxide. [1] sulfur dioxide reacts with water and oxygen [0.5] to form acid rain [0.5] which makes soil and water acidic.	[2]
	b	Calcium hydroxide will react with the fertilizer to form ammonia gas Loss of nitrogen	[1] [1]
	c	Add <u>acidified</u> barium nitrate, White precipitate formed, Add aqueous ammonia in excess, White precipitate formed insoluble in excess aqueous ammonia. Aluminium ion present as lead(II)sulfate is insoluble/aluminium sulfate is soluble	[0.5] [0.5] [0.5] [0.5] [0.5] [0.5]
B3	a	$4\text{OH}^- \rightarrow \text{O}_2 + 2\text{H}_2\text{O} + 4\text{e}^-$	[1]
	B	$\text{Cr}^{3+} + 3\text{e}^- \rightarrow \text{Cr}$ Mol of Cr = $13/52 = 0.25\text{mol}$ Mol of e = 0.75mol $\text{X}^{2+} + 2\text{e}^- \rightarrow \text{X}$ Mol of Metal = $0.75/2 = 0.375\text{mol}$ Ar of X = $24/0.375 = 64$ Cation is Cu^{2+}	[0.5] [0.5] [0.5] [0.5] [1]
	ci	The oxidation state of chlorine increases from <u>-1 (in Cl⁻) to 0 (in Cl₂)</u> . Oxidation occurs	[0.5] [0.5]
	li	Some of the chlorine gas dissolved in water.	[1]

	d	Add <u>excess</u> <u>chromium oxide/carbonate</u> to (dilute) <u>nitric acid</u> . <u>Filter the mixture</u> (to obtain the filtrate) <u>Crystallise</u> the filtrate <u>Filter the mixture</u> to obtain the crystal, <u>Wash</u> the crystal with (small amount of) <u>distilled water</u> , <u>dry</u> the crystals between <u>sheets of filter paper</u>	[0.5] [0.5] [0.5] [0.5] [0.5] [0.5]
--	----------	--	--

Section C (20 marks)

C1	a	Moles of NaOH = $0.01 \times 0.1 = 0.001$ mol Moles of HCl = 0.001 mol Concentration = $0.001/0.025 = 0.04$ mol/dm ³	[0.5] [0.5] [1]
	b	pH of ethanoic acid <u>4</u> and pH of hydrochloric acid is <u>2</u> /pH of ethanoic acid is higher by <u>2</u> . Ethanoic acid weak hydrochloric acid strong <u>Ethanoic acid partial ionize/dissociate in water</u> to form hydrogen ion <u>Hydrochloric acid completely ionize/dissociate in water</u> to form hydrogen ion	[0.5] [0.5] [0.5] [0.5]
	c	Phenolphthalein /Bromothymol blue It is <u>within the range</u> of the <u>pH change /endpoint for experiment</u> .	[1] [1]
	d	pH start at 2 and end at 11 and same shape as expt 1 End point volume = 5cm ³	[1] [1]
	e	An insoluble lead(II) chloride is formed over the reactant lead(II) oxide. Incomplete reaction of HCl/left over excess acid	[1] [1]
C2	a	X. It has high bpt and mpt it formed coloured compound.	[1] [1]
	b	<i>Y is obtained by <u>electrolysis of molten oxide of Y</u></i> <i>X is obtained by <u>chemical reduction of oxide of X</u></i>	[1] [1]
	c	V react faster with chlorine than bromine. Down the group, number of protons and electron shells increase so nuclear charge and shielding increases Shielding effect increases more than nuclear charge Effective nuclear charge decreases Weaker (electrostatic forces) of attraction between the valence electrons and the nucleus, making it more difficult for the element to <u>gain electrons</u> .	[0.5] [0.5] [0.5] [0.5] [0.5] [0.5]
	d	$2V + 2H_2O \rightarrow 2VOH + H_2$	[1]

	ei	lead	[1]
	eii	Z is less reactive than iron. [0.5]It does not corrode in place of iron.[0.5]	[1]