

Visit

FreeTestPaper.com

for more papers

FAIRFIELD METHODIST SCHOOL (SECONDARY)

**PRELIMINARY EXAMINATION 2016
SECONDARY 4 EXPRESS**

CHEMISTRY

5073/01

Paper 1

Date: 22 August 2016

Duration: 1 hour

READ THESE INSTRUCTIONS FIRST

Write your name, class and register number in the spaces at the top of this page.

There are forty questions on this paper. Answer all questions.

For each question, there are four possible answers A, B, C and D.

Choose the one you consider correct and record your choice in soft pencil on the separate OTAS sheet.

Read very carefully the instructions on the OTAS.

Each correct answer will score one mark. A mark will not be deducted for a wrong answer.

Any rough working should be done in this question paper.

Hand in your OTAS at the end of the paper.

A copy of the Periodic Table is printed on page 16.

Setter: Ms K Chin & Ms C Koh

This document consists of **16** printed pages including the cover page.

Answer all questions.
Record your answer on the OTAS sheet provided.

- 1 The apparatus below consists of a porous pot containing gas E which is surrounded by gas F in a beaker.

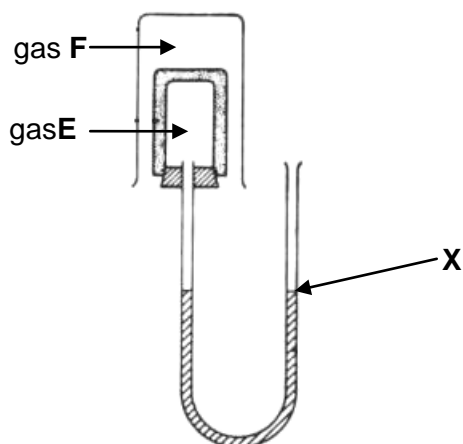

Which pair of gases would cause the water level at X to move upwards initially?

	Gas E	Gas F
A	ammonia	carbon monoxide
B	carbon dioxide	hydrogen
C	ethene	nitrogen
D	oxygen	propane

- 2 Dyes J, K, L and M were placed on four spots on the chromatography paper and run using a solvent. The diagram on the left shows the positions of the spots before chromatography while the diagram on the right shows the position of the spots after chromatography.

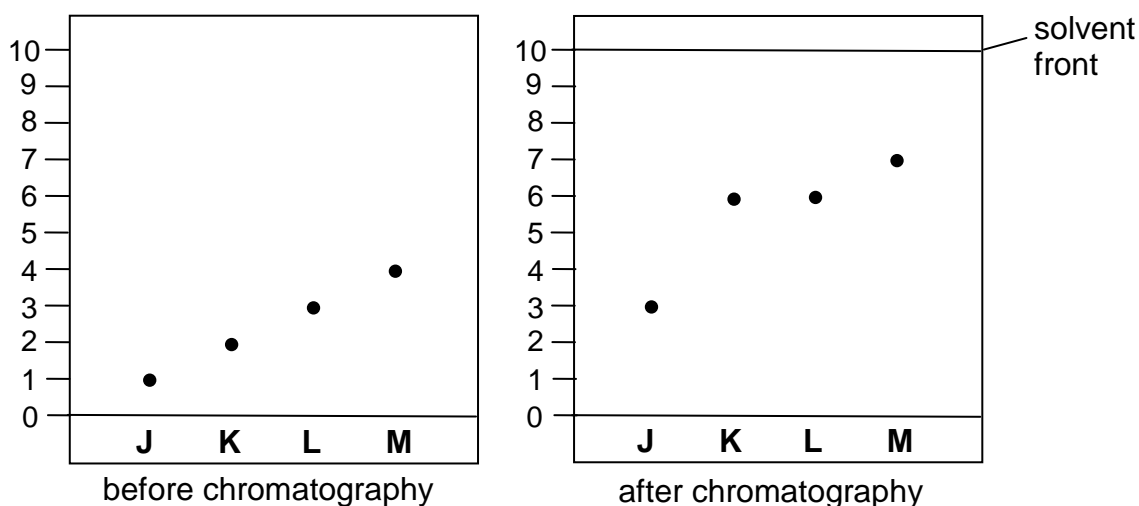

Which two dyes are identical?

- A J and K
- B K and L
- C K and M
- D L and M

- 3 The diagram shows apparatus used to obtain carbon monoxide.

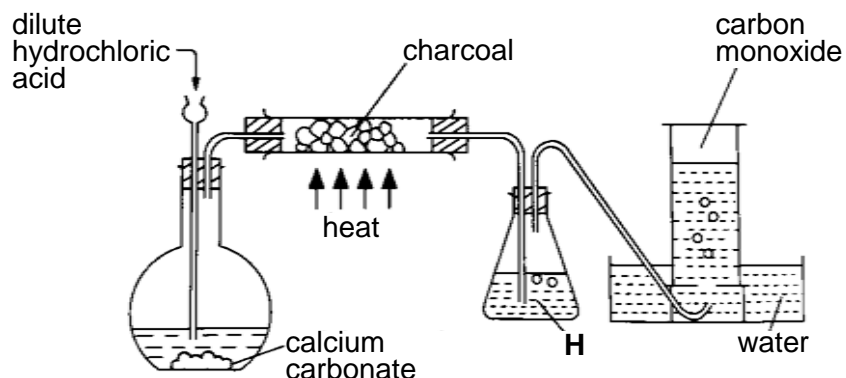

What is the main purpose of **H**?

- A to dry the gas
 - B to prevent water being sucked back on to the hot carbon
 - C to remove carbon dioxide from the gas
 - D to remove hydrogen chloride from the gas
- 4 A sample of reddish-brown powdery solid was placed in a beaker containing water and stirred. The contents of the beaker are then filtered to obtain a black residue. The filtrate is then evaporated to dryness, leaving behind a red solid.

Which statement is true?

- A The black solid is an element.
 - B The red solid is an element.
 - C The reddish brown solid is a compound.
 - D The reddish brown solid is a mixture.
- 5 An element, **T**, has p protons and n neutrons in its nucleus.

Which row gives a possible correct number of protons, neutrons and electrons in a negative ion of an isotope of **T**?

	protons	neutrons	electrons
A	p	$n + 1$	$p + 1$
B	p	$n + 1$	$p - 1$
C	$p + 1$	n	$p + 1$
D	$p + 1$	n	$p - 1$

- 6 Germanium is found in Group IV of the Periodic Table.

Which compound of Germanium is unlikely to exist?

- A Ge_2H_6
- B GeN_3
- C GeO
- D GeS_2

- 7 The table shows physical properties of three substances, **R**, **S** and **T**.

substance	melting point / $^{\circ}\text{C}$	electrical conductivity	
		at 0°C	at 1000°C
R	860	poor	good
S	98	good	good
T	3640	good	good

What could substances **R**, **S** and **T** be?

	R	S	T
A	calcium	zinc	copper
B	calcium oxide	mercury	diamond
C	potassium fluoride	sodium	graphite
D	sulfur	iodine	titanium

- 8 The bonding in arsenic trioxide can be represented by the structure shown.

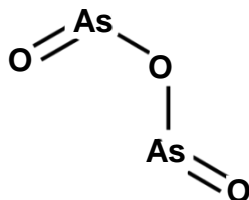

What is the total number of electrons **not** involved in bonding?

- A 12
 - B 22
 - C 28
 - D 78
- 9 Gas **G** has a density of $1.17\text{g}/\text{dm}^3$ at room temperature and pressure.

What is gas **G**?

- A ammonia
- B carbon dioxide
- C nitrogen
- D oxygen

- 10 The contents of three beakers shown are poured together and mixed to obtain a homogeneous solution.

beaker 1	beaker 2	beaker 3
50cm ³ of 1.0mol/dm ³ of NaCl	250cm ³ of 1.0mol/dm ³ of MgCl ₂	0.2dm ³ of water

Which option shows the correct concentration of ions, in mol/dm³, of the resulting solution?

	Na ⁺	Mg ²⁺	Cl ⁻
A	0.05	0.25	0.50
B	0.05	0.25	0.60
C	0.10	0.50	1.00
D	0.10	0.50	1.10

- 11 The relative molecular masses of copper(II) sulfate, CuSO₄, and water are 160 and 18 respectively.

What is the percentage by mass of water in hydrated copper(II) sulfate, CuSO₄.5H₂O?

- A** $\frac{18 \times 100}{160}$
- B** $\frac{5 \times 18 \times 100}{160}$
- C** $\frac{18 \times 100}{160 + 18}$
- D** $\frac{5 \times 18 \times 100}{160 + (5 \times 18)}$

- 12 Which method of salt preparation produces the best yield of calcium sulfate?

- A** add dilute nitric acid to calcium carbonate followed by dilute sulfuric acid
- B** add solid calcium carbonate to dilute sulfuric acid
- C** heat calcium carbonate to complete decomposition followed by addition of sulfuric acid
- D** mix silver sulfate solution with calcium chloride solution

- 13 The dissociation constant for an acid indicates the extent to which it dissociates into ions. The higher the dissociation constant, the stronger the acid.

The dissociation constants for some acids are stated in the table along with two possibly correct statements.

acid	dissociation constant
methanoic acid, HCO_2H	1.80×10^{-4}
ethanoic acid, $\text{CH}_3\text{CO}_2\text{H}$	1.75×10^{-5}
propanoic acid, $\text{CH}_3\text{CH}_2\text{CO}_2\text{H}$	1.34×10^{-5}
chloroethanoic acid, $\text{ClCH}_2\text{CO}_2\text{H}$	1.40×10^{-3}

statement 1	Increasing the length of the carbon chain makes the acid stronger.
statement 2	Replacing a hydrogen atom with a chlorine atom in ethanoic acid makes the acid stronger.

Based on the data above, which statements are correct?

- A both statements
B statement 1 only
C statement 2 only
D neither statement
- 14 Three aqueous solutions have pH values shown in the table.

solution	X	Y	Z
pH	3	5	6

- I Solution Y reacts with an alcohol to form an ester.
II Mixing solution X and solution Y gives a solution with a pH value of 4.
III Mixing solutions X, Y and Z in equal volume gives an acidic solution.

Which statement is true for X, Y and Z?

- A I only
B II only
C III only
D none of the statements
- 15 In which reaction is the underlined substance acting as a reducing agent?
- A chlorine + iron(II) chloride \rightarrow iron(III) chloride
B hydrogen + copper(II) oxide \rightarrow copper + water
C hydrochloric acid + magnesium oxide \rightarrow magnesium chloride + water
D zinc oxide + carbon monoxide \rightarrow zinc + carbon dioxide

16 Talc is a mineral which has the formula $\text{Mg}_3\text{Si}_4\text{O}_{10}(\text{OH})_2$.

What is the oxidation state of silicon?

- A -4
- B -2
- C +2
- D +4

17 The table shows a series of experiments carried out on the compounds of four metals, **E**, **F**, **G** and **H**.

Metal	Experiment		
	metal carbonates heated under inert conditions	metal oxides heated with carbon	metal oxide heated with hydrogen
E	carbon dioxide evolved	no reaction	no reaction
F	no reaction	no reaction	no reaction
G	carbon dioxide evolved	reduced	reduced
H	carbon dioxide evolved	reduced	no reaction

Arrange the metal in increasing order of reactivity.

- A **F, E, H, G**
- B **F, H, E, G**
- C **G, E, H, F**
- D **G, H, E, F**

18 Alloys are usually harder than the metals which they are made from.

Which statement best explains the hardness of the alloy?

- A The atomic radii of the metal and the other elements present in the alloy are different.
- B The other elements present in the alloy are of a lower reactivity than the metal.
- C The other elements present in the alloy have a higher density than the metal.
- D The relative atomic masses of the metal and the other elements present in the alloy are different.

19 Scrap iron is often recycled.

Which reason for recycling is **not** correct?

- A It reduces the amount of pollution at the site of the ore extraction.
- B It reduces the amount of waste taken to landfill sites.
- C It reduces the need to collect scrap iron.

- 23 The table shows the energy released by complete combustion of some fuels.

fuel	formula	enthalpy change of combustion, kJ/mol
methane	CH ₄	-880
ethanol	C ₂ H ₅ OH	-1380
propane	C ₃ H ₈	-2200
butene	C ₄ H ₈	-2716

Which fuel produces the most energy when 1g of the fuel is completely burned?

- A ethanol
 B butene
 C methane
 D propane
- 24 The scheme shows four stages I to IV in the process involving the production, storage and usage of hydrogen as a fuel.

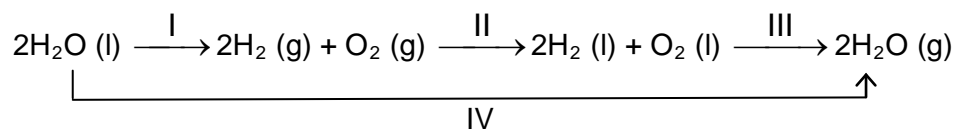

Which stages are endothermic?

- A I and II
 B I and IV
 C II and III
 D III and IV

- 25 Two experiments were carried out to determine the rate of reaction between copper(II) carbonate and nitric acid. The rate of reaction was followed by measuring the volume of carbon dioxide produced at regular time intervals. Curve **P** displays the result obtained by reacting excess copper(II) carbonate with nitric acid.

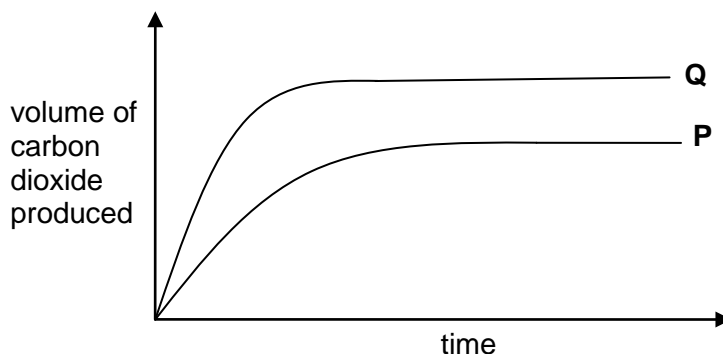

What change to one of the conditions will produce the results curve **Q** displays?

- A A catalyst was used.
 - B The concentration of nitric acid used is increased.
 - C The mass of copper(II) carbonate used is increased.
 - D The volume of nitric acid used is increased.
- 26 24 dm³ of nitrogen is reacted with 36 dm³ of hydrogen to produce ammonia.

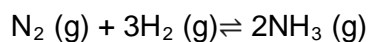

Which change would result in an increase in both the speed of reaction and percentage yield of ammonia?

- A adding a suitable catalyst
- B increasing the pressure
- C increasing the temperature
- D use twice the volume of nitrogen and hydrogen

Refer to the information below for questions 27 and 28.

The labels of five colourless solutions below were missing from their containers and a qualitative analysis was conducted in an attempt to identify the five solutions.

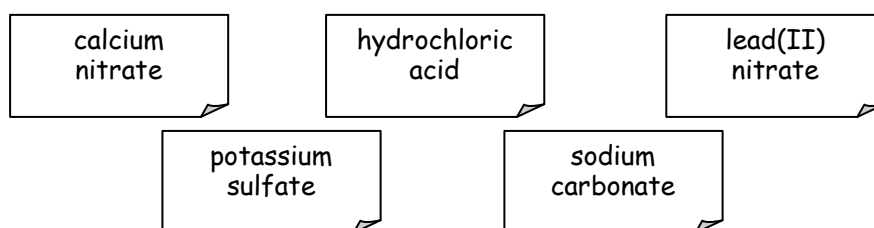

Equal volumes of two solutions were mixed with one another each time and the observations are recorded in the table.

Solutions	1	2	3	4	5
1	-	no visible reaction	white precipitate formed	white precipitate formed	white precipitate formed
2	no visible reaction	-	no visible reaction	white precipitate formed	white precipitate formed
3	white precipitate formed	no visible reaction	-	no visible reaction	effervescence observed
4	white precipitate formed	white precipitate formed	no visible reaction	-	no visible reaction
5	white precipitate formed	white precipitate formed	effervescence observed	no visible reaction	-

27 What is solution 1?

- A calcium nitrate
- B hydrochloric acid
- C lead(II) nitrate
- D potassium sulfate

28 What is solution 2?

- A calcium nitrate
- B hydrochloric acid
- C lead(II) nitrate
- D potassium sulfate

- 29 In the circuit below, an electric current is passed through three cells all with aqueous copper(II) sulfate as the electrolyte.

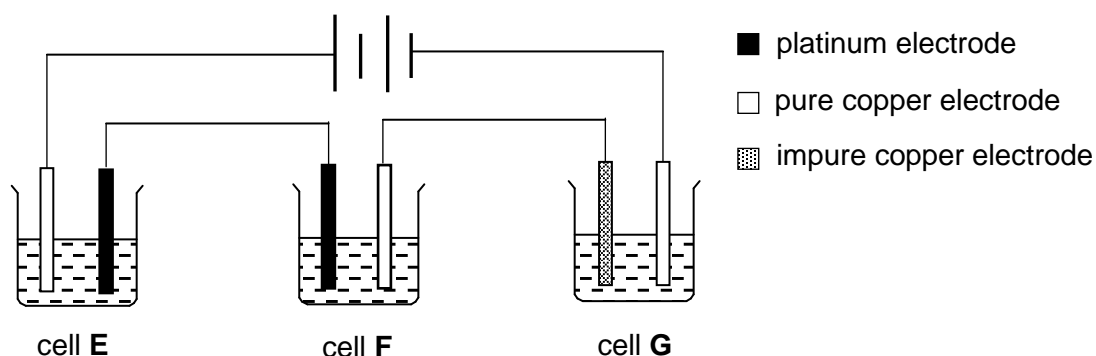

In which cell(s) will a change in the colour intensity of the electrolyte be observed?

- A cell F
B cells E and G
C cells F and G
D cells E, F and G
- 30 The diagram shows three different electrochemical cells, each containing two of the three metals, M, N and O, immersed in sodium nitrate solution. The voltage of each electrochemical cell is shown below each cell. The direction of electron flow in cell 1 is from right to left.

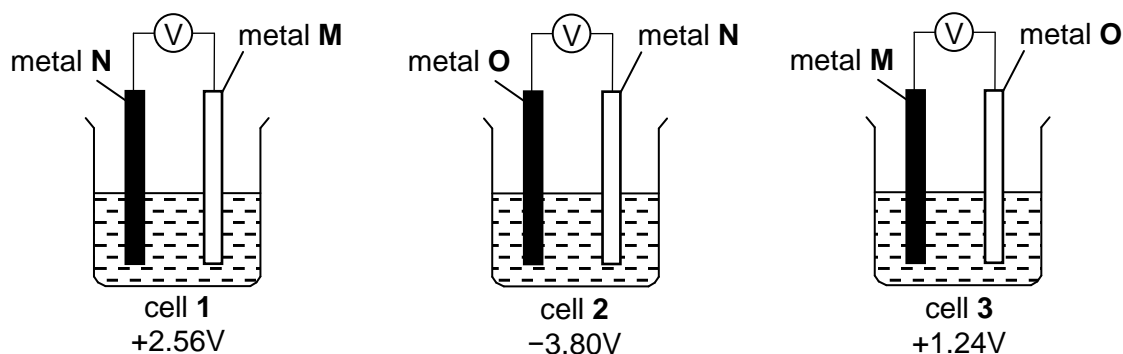

What is the ascending order of reactivity of the metals?

- A M, N, O
B N, M, O
C O, M, N
D O, N, M

- 31 A student carried out an electrolysis experiment using a battery, two electrodes and an electrolyte.

As the reaction proceeded, she recorded her observations and wrote down these two half-cell equations to represent the reactions that occurred.

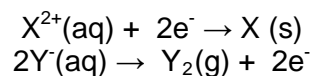

Which set of observations corresponds with the two half-cell equations she wrote?

	half-cell equation	electrode	mass of electrode after 15 min
A	$X^{2+}(\text{aq}) + 2e^{-} \rightarrow X(\text{s})$	anode	decreases
B	$X^{2+}(\text{aq}) + 2e^{-} \rightarrow X(\text{s})$	cathode	increases
C	$2Y^{-}(\text{aq}) \rightarrow Y_2(\text{g}) + 2e^{-}$	anode	increases
D	$2Y^{-}(\text{aq}) \rightarrow Y_2(\text{g}) + 2e^{-}$	cathode	decreases

- 32 A catalytic converter is used to convert pollutants into less harmful products in a car exhaust system.

Which change does **not** occur in a catalytic converter?

- A carbon dioxide \rightarrow carbon
- B carbon monoxide \rightarrow carbon dioxide
- C oxides of nitrogen \rightarrow nitrogen
- D unburnt hydrocarbons \rightarrow carbon dioxide and water

- 33 The atmosphere of a newly discovered planet contains the following gases.

carbon dioxide	20%
nitrogen	40%
noble gases	10%
oxygen	30%

The diagram shows the apparatus that was set up with a 100 cm³ sample of the atmosphere of the planet in the graduated tube. The volume of the sample was measured at intervals until no further change in volume took place.

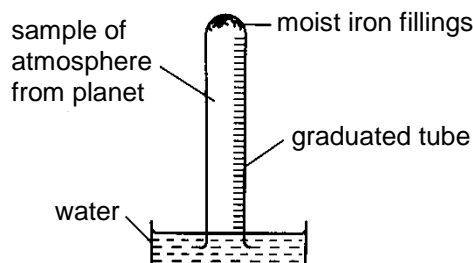

What volume of the sample would remain?

- A 10 cm³
- B 30 cm³
- C 40 cm³
- D 70 cm³

34 In what way do CFCs, methane and carbon dioxide affect the environment?

	CFCs	methane	carbon dioxide
A	depletion of ozone layer	global warming	greenhouse gas
B	depletion of ozone layer	greenhouse gas	acid rain
C	global warming	acid rain	depletion of ozone layer
D	global warming	greenhouse gas	acid rain

35 Thermal depolymerisation is a method of recycling waste polymers. Under high temperature and pressure, long chain polymers decompose to form a mixture of short chain petroleum hydrocarbons with a maximum chain length of around 18 carbon atoms. The mixture of hydrocarbons can be separated in a separating column as shown.

Which fraction consists of hydrocarbons with around 18 carbon atoms?

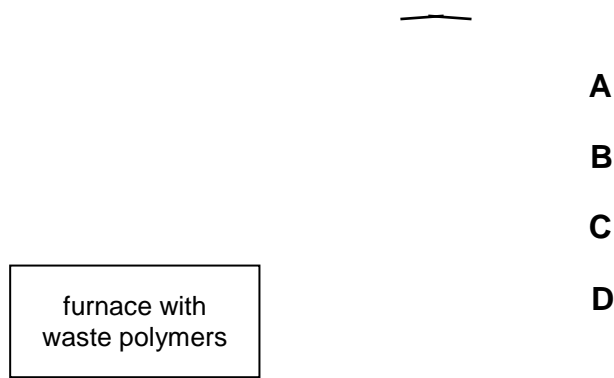

36 Glycerin, is commonly used in moisturizing skincare products to attract water from the environment to the skin.

The structure of glycerin is shown.

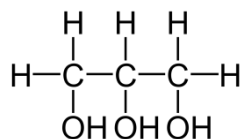

Which is not an isomer of glycerin?

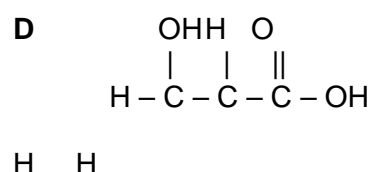
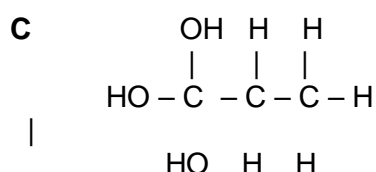
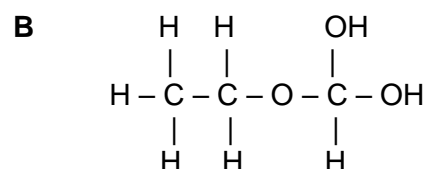
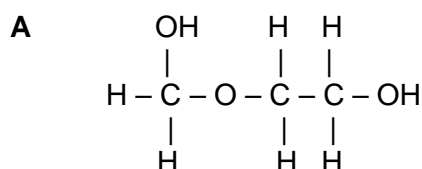

- 37 A hydrocarbon reacts with fluorine in the reaction shown.

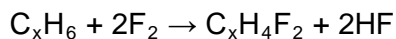

Which statement is correct?

- A It is an addition reaction.
 B The hydrocarbon is unsaturated.
 C The molecular formula of the hydrocarbon is C_3H_6 .
 D Ultraviolet light is required for the reaction to take place.
- 38 Which statement about the compound shown below, is incorrect?

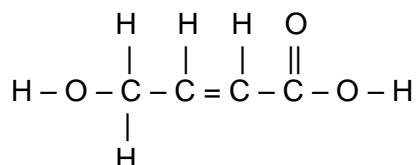

- A It decolourises aqueous bromine.
 B It decolourises acidified potassium manganate.
 C It forms an amide linkage when reacted with itself.
 D It reacts with magnesium to produce hydrogen gas.
- 39 Which reaction(s), **W**, **X**, **Y** and/or **Z** involve(s) oxidation?

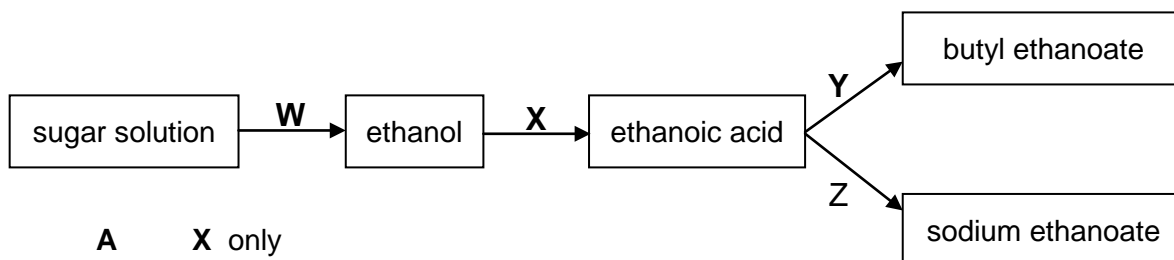

- A X only
 B W and X
 C X and Y
 D Y and Z
- 40 The repeating units of two polymers, **P** and **Q** are shown.

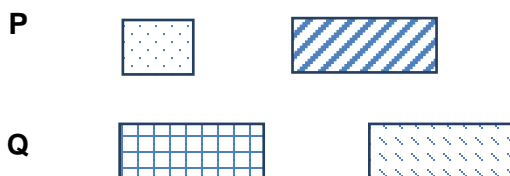

What are **P** and **Q**?

	P	Q
A	fats	starch
B	nylon	protein
C	starch	fats
D	terylene	nylon

END OF PAPER

FAIRFIELD METHODIST SCHOOL (SECONDARY)

PRELIMINARY EXAMINATION 2016 SECONDARY 4 EXPRESS

CHEMISTRY

5073 / 02

Paper 2

Date: 19 August 2016

Duration: 1h 45 min

READ THESE INSTRUCTIONS FIRST

Write your name, index number and class on all the work you hand in.

Write in dark blue or black pen.

You may use a pencil for any diagrams or graphs.

Do not use staples, paper clips, glue or correction fluid.

Section A

Answer **all** questions in the space provided.

Sections B

Answer **all** three questions, the last question is in the form either /or.

At the end of the examination, fasten all your work securely together.

The number of marks is given in bracket [] at the end of each question or part question.

The total number of marks for this paper is 80.

A copy of the Periodic Table is printed on page 20.

**Parent's/Guardian's
Signature:**

For Examiner's Use	
Section A	/ 50
Section B	
B7	/ 10
B8	/ 10
B9	/ 10
Total	/ 80

Setters: Ms C Koh and Ms K Chin

This document consists of **20** printed pages including the cover page.

Section A

Answer all questions in this section in the spaces provided.

The total marks for this section is 50.

A1 The diagram shows the percentages of some elements found in the earth's crust.

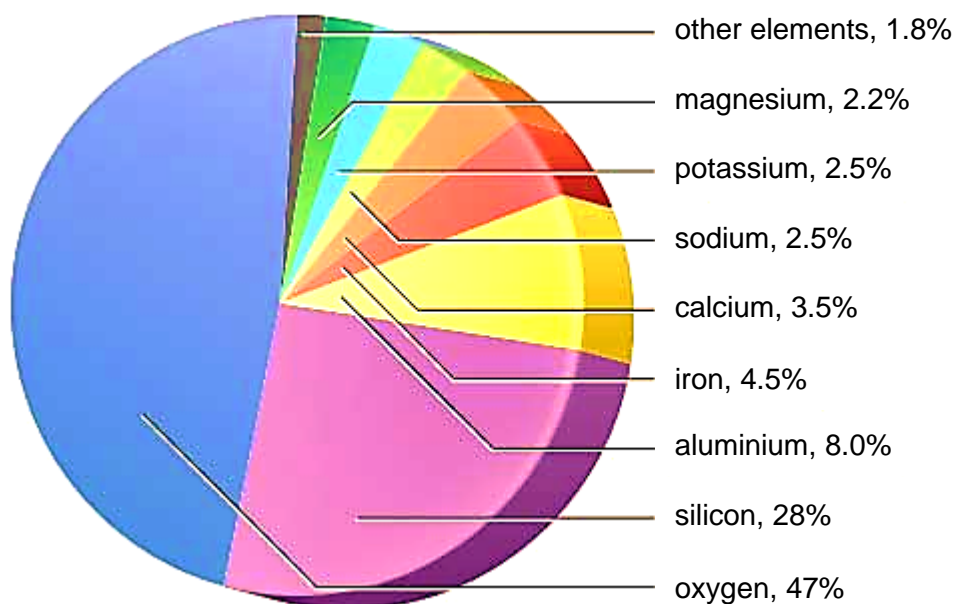

(a) State the chemical formula of the compound formed by the two most abundant elements found in the earth's crust.

.....[1]

(b) Which element forms an oxide that reacts with both acids and bases?

.....[1]

(c) Which element forms coloured compounds?

.....[1]

(d) Which element can only be extracted by electrolysis?

.....[1]

(e) Suggest why oxygen can be found in the earth's crust.

.....

.....[1]

A2 The table shows the concentration of different ions found in a sample of aqueous industrial waste from a chemical plant.

ion	concentration in mol/dm ³
H ⁺	3.30
K ⁺	0.42
Na ⁺	0.17
NO ₃ ⁻	1.55
Pb ²⁺	0.32
Zn ²⁺	0.23

(a) What would be observed when the aqueous industrial waste is tested with universal indicator? Explain your answer.

.....
[2]

(b) The aqueous industrial waste is treated with aqueous ammonia before it is disposed into the sea.

(i) Upon reaction with aqueous ammonia, some metal ions can be removed from the industrial waste.

Name the chemical method involved in this process.

.....[1]

(ii) The volume of aqueous ammonia added must be carefully calculated before adding to the sample.

Suggest why adding an excess volume of aqueous ammonia will be ineffective in removing Zn²⁺ ions.

.....

[2]

(iii) Identify two cations that cannot be removed by this method and state reason for it.

a

.....
[2]

- (c) Another bottled sample is obtained from the chemical plant as shown.

This aqueous sample contains Pb^{2+} and Al^{3+} ions

Describe how the highly toxic Pb^{2+} ions can be removed from the sample. Include a suitable reagent in your description.

.....
.....
.....[2]

- A3** The table shows how elements in Group II of the Periodic Table react with cold water.

element	reaction with cold water
magnesium	reacts slowly with cold water
calcium	reacts readily with cold water
strontium	reacts vigorously with cold water
barium	reacts very vigorously with cold water
radium	

- (a) Write the chemical formula of the products formed when magnesium reacts with cold water.

.....[2]

- (b) Radium is the last member in Group II.

- (i) Predict how radium reacts with cold water.

.....[1]

- (ii) Suggest how radium should be stored.

.....[1]

- (c) Describe the relationship between the reactivity and atomic size of the Group II elements. Suggest an explanation for the relationship.

.....
.....
.....[3]

(d) When strontium is heated in chlorine gas, they react to form a compound.

(i) Draw the electronic structure of the compound formed between strontium and chlorine. Show only the valence electrons.

[2]

(ii) Using ideas about bonding and structure, predict the physical state of the compound formed and explain why it is in that state.

.....
.....
.....
.....[3]

A4 Three experiments were carried out in order to determine the order of reactivity of three metals, **X**, **Y** and **Z**.

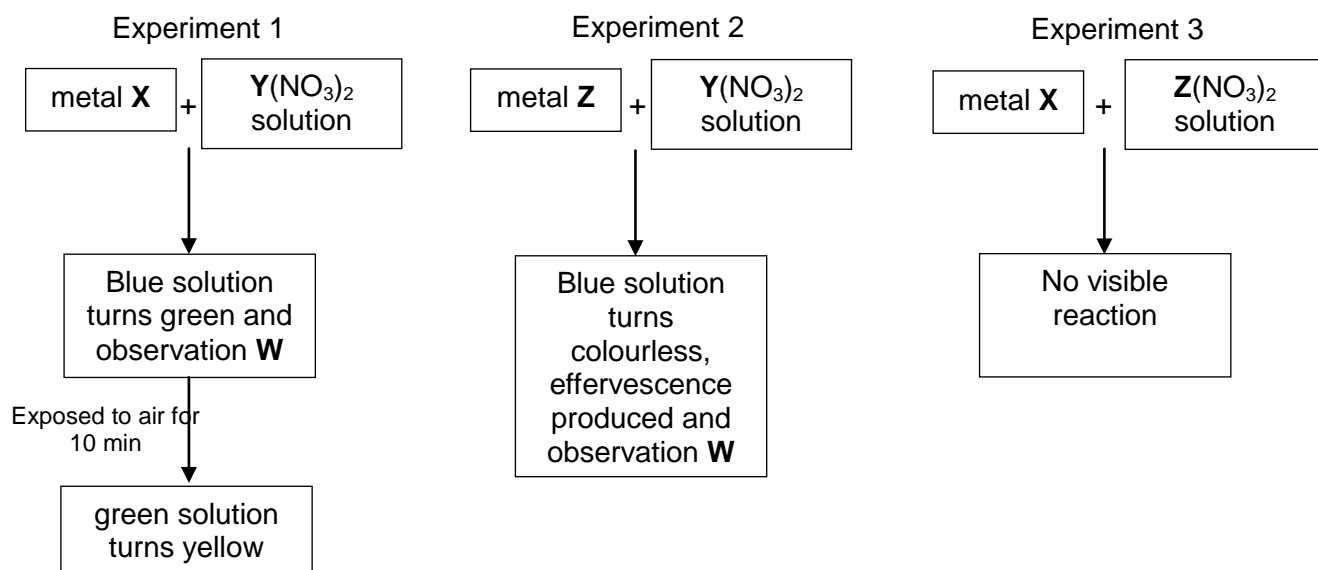

- (a) From Experiment 1,
- (i) Identify metal **X**.
[1]
- (ii) State observation **W**.
[1]
- (iii) Write an ionic equation for the reaction between metal **X** and $\text{Y}(\text{NO}_3)_2$.
[1]
- (b) Describe an experiment to test for the gas produced in Experiment 2.

[1]
- (c) Arrange metals **X**, **Y** and **Z** in order of descending reactivity.
[1]

A5 Vanadium is a transition metal.

(a) The vanadium(III) ion can behave as an oxidising or reducing agent.

The reaction of vanadium(III) ions with iron(III) ions is a redox reaction.

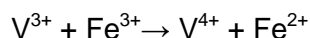

Explain in terms of electron transfer whether the vanadium(III) ion is acting as an oxidising or reducing agent in this reaction.

.....
.....
.....[2]

(b) Vanadium reacts with the polyatomic cyanide ion, CN^- , to form vanadium cyanide.

A compound of vanadium cyanide has the following composition:

element	percentage by mass
vanadium	28%
carbon	33%
nitrogen	39%

(i) Deduce the empirical formula of this compound.

[2]

(ii) State the oxidation state of vanadium in the compound.

.....[1]

(c) Iron is another transition metal that is more commonly used. It can be extracted in the blast furnace from its ore, haematite, by reduction.

(i) Write the chemical equation, including state symbols, to show how iron can be obtained in the blast furnace.

.....[2]

(ii) Limestone is added to the blast furnace to remove impurities. Explain how limestone is able to do so.

.....
.....[2]

A6 Ammonia is manufactured in the Haber Process with hydrogen and nitrogen gases as reactants.

A schematic diagram of the Haber Process is shown.

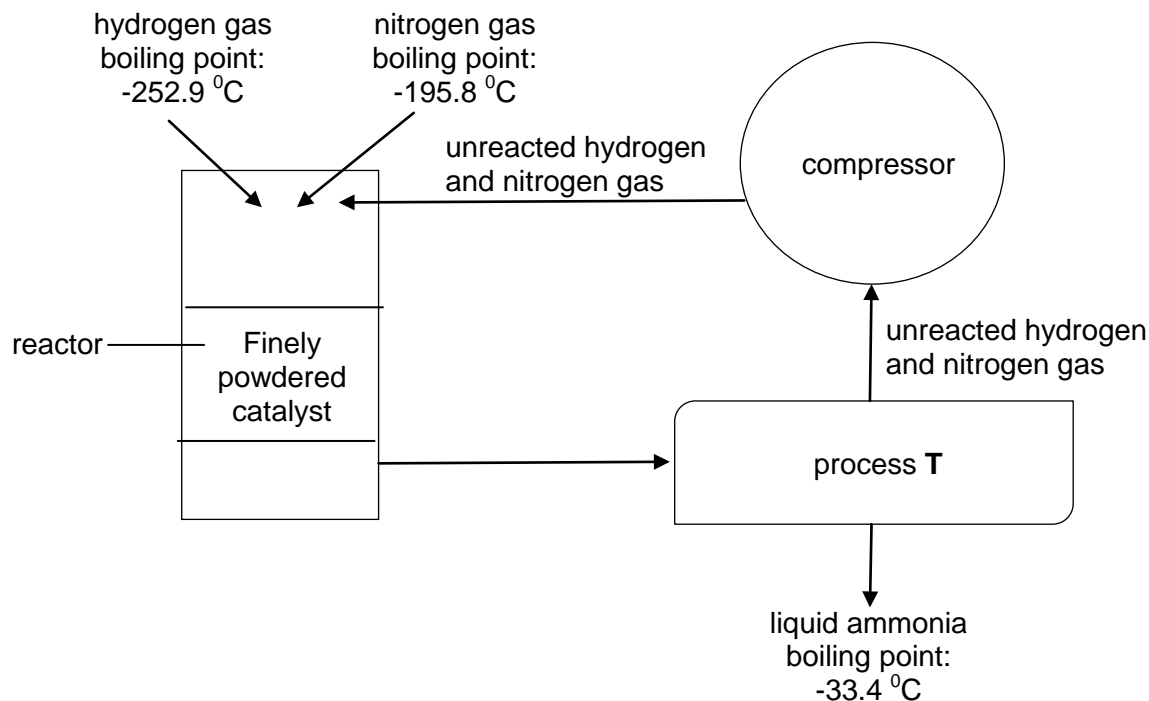

(a) State a source of hydrogen gas.
[1]

(b) Explain why it is important that no air is allowed into the reactor.

[1]

(c) Name process T and suggest why this process can be used to obtain ammonia from the mixture.

[2]

(d) The catalyst used in the reactor is iron. Suggest why finely powdered iron is used instead of a strip of iron.

[3]

- (e) The graph shows the percentage yield of ammonia in the equilibrium mixture under different temperature and pressure conditions.

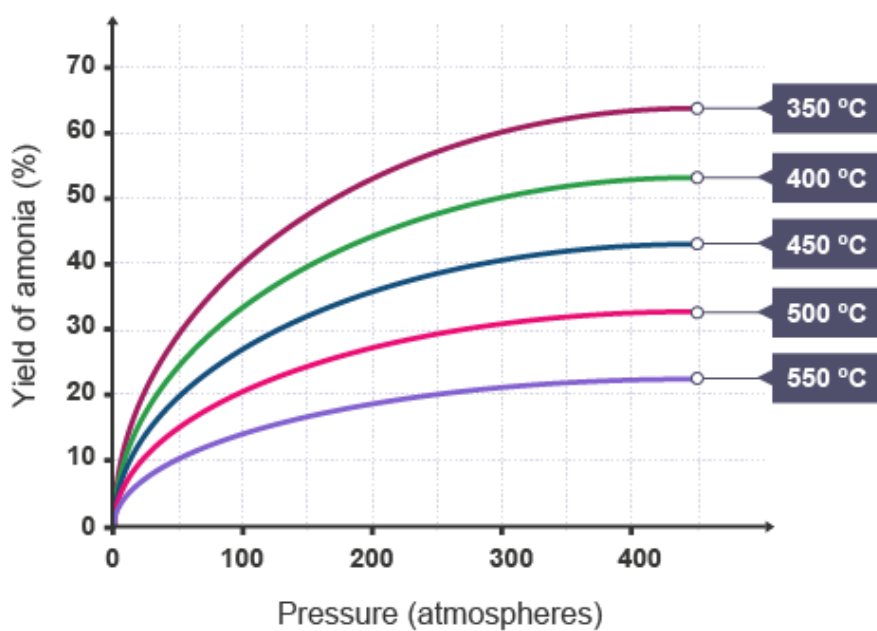

- (i) From the graph, state the conditions required to produce the greatest percentage yield of ammonia.

.....[1]

- (ii) Suggest two reasons why the conditions stated in part (e)(i) are not used commercially.

.....
.....
.....[2]

Section B [30 marks]

Answer all three questions in this section in the spaces provided.

The last question is in the form of either/or and only one of the alternatives should be attempted.

B7 The diagram shows the cross-section of a zinc-carbon battery.

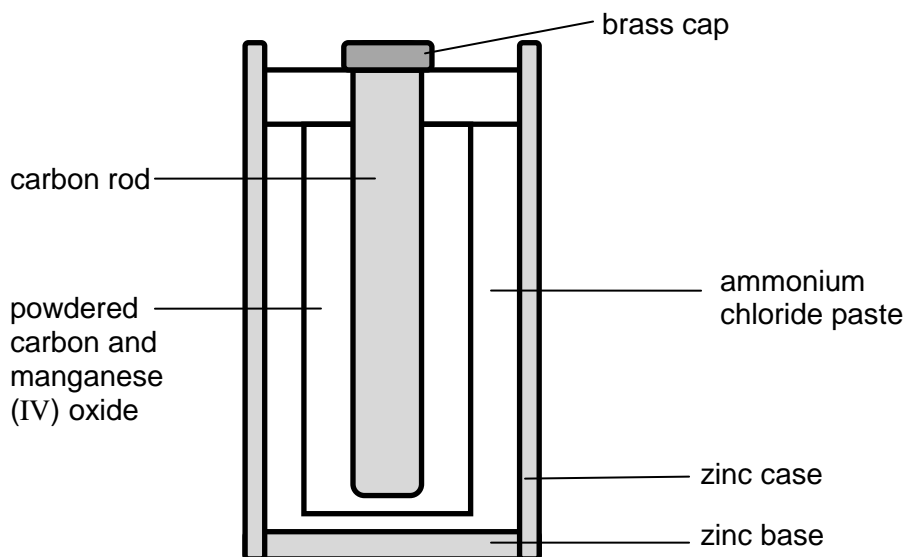

The equation represents the overall reaction in a battery.

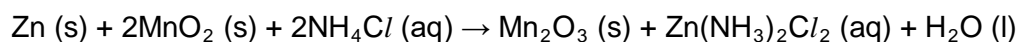

Ammonia gas and hydrogen gas are produced at the carbon electrode. Hydrogen gas reacts with manganese (IV)oxide, MnO_2 , to give water, while ammonia gas reacts with zinc chloride, ZnCl_2 , to give $\text{Zn(NH}_3)_2\text{Cl}_2$.

(a) State the electrolyte present in the battery.

.....[1]

(b) Write the ionic half-equations for the reactions occurring at the electrodes.

Cathode:

Anode:[2]

(c) After prolonged usage, explain why leaking of ammonium chloride paste will occur.

.....
[1]

(d) Two zinc-carbon batteries are used in the set up below for electroplating a metal ring with a thin layer of silver. 500 cm^3 of 0.05 mol/dm^3 of silver nitrate solution was used

as the electrolyte.

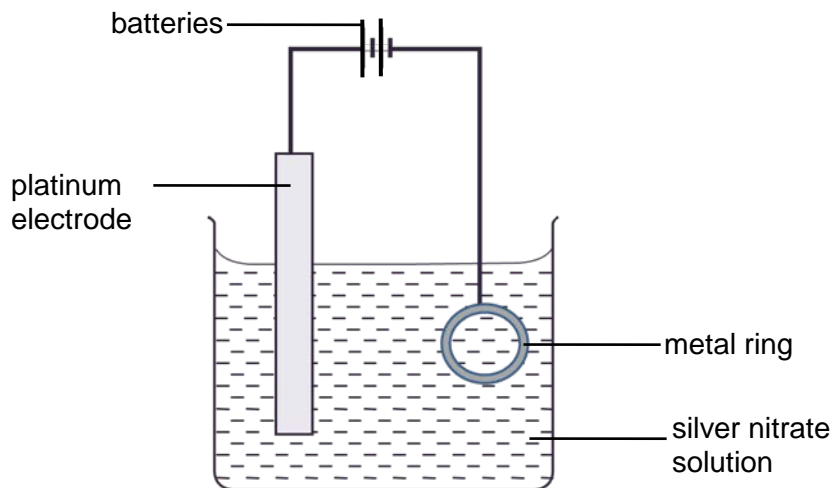

The graph shows the mass of silver deposited on the metal ring over time.

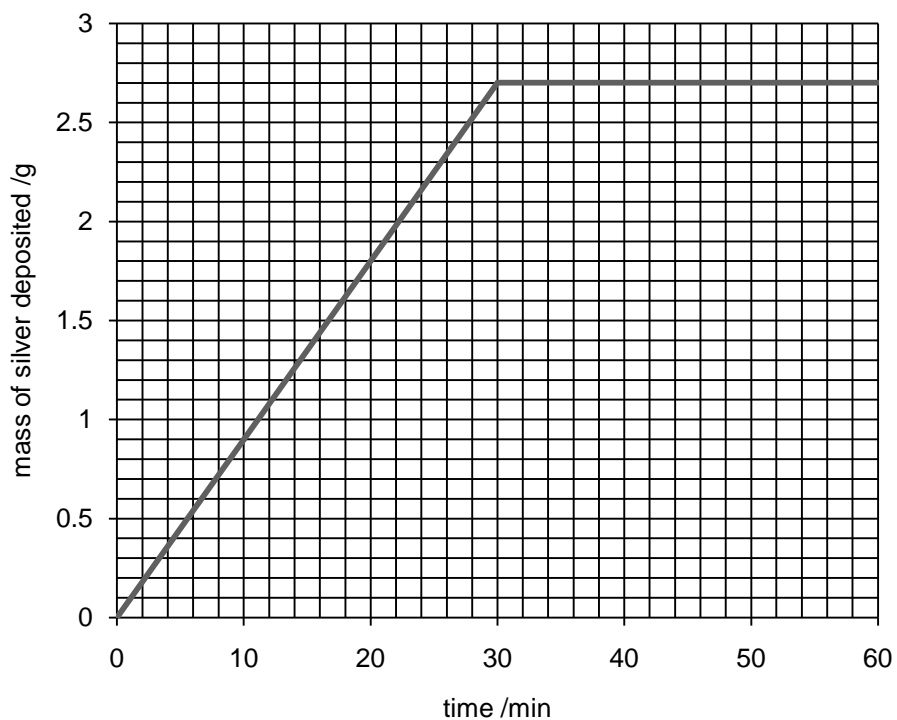

(i) Gas X was produced at the platinum electrode during the process of electroplating. Identify gas X.

.....[1]

(ii) Explain the shape of the graph after 30 minutes of electroplating.

.....
.....[1]

(iii) Calculate the concentration of silver nitrate solution, in mol/ dm³, at the 10th minute of electroplating. (assume change in volume of solvent to be negligible)

[3]

- (iv) Calculate the mass of zinc consumed from the battery, in g, at the 10th minute of electroplating.

[2]

- B8** A growing concern for the environment has promoted a shift towards the use of cleaner sources of energy such as hydrogen fuel. Currently, the dominant technology for the production of hydrogen is through steam reforming of hydrocarbons.

Steam-methane reforming is a method used for producing hydrogen from natural gas. In the process, methane reacts with steam to produce carbon monoxide and hydrogen.

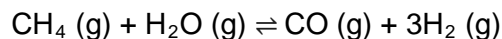

The carbon monoxide produced can be further reacted with steam to produce more hydrogen in the water-gas shift reaction.

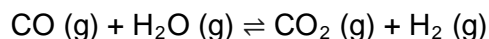

- (a) The bond energies of various bonds are shown in the table.

bond	bond energy (kJ/mol)
C=O	805
C-H	415
C≡O in CO	1080
O-H	464
H-H	436

Calculate the enthalpy change of the steam-methane reforming reaction.

[2]

- (b) Sketch the energy profile diagram of the steam-methane reforming reaction.



[2]

(c) What is the maximum mass of hydrogen that can be produced from 1 kg of methane?

[3]

(d) Write the chemical equation for the steam-propane reforming reaction.

.....[1]

(e) An advantage of using hydrogen as a fuel is that it does not cause pollution as water is the only product formed when hydrogen is combusted.

However, an environmentalist commented that using hydrogen as a fuel contributes to carbon dioxide emissions as well. Explain why.

.....
.....[1]

EITHER

B9 The table shows some information about the homologous series of organic compounds called aldehydes.

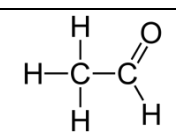
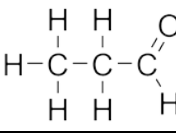
name	condensed formula	full structural formula
ethanal	CH ₃ CHO	
	C ₂ H ₅ CHO	
butanal		

(a) (i) Complete the table to show the name, condensed formula and structural formula of the aldehydes. [2]

(ii) Explain how you can tell that these molecules are from the same homologous series.

.....
.....[1]

(iii) Predict the condensed formula of the aldehyde containing 18 carbons.

.....[1]

(b) When an alcohol reacts with excess acidified potassium dichromate (VI), a carboxylic acid is formed. When excess alcohol is used instead, an aldehyde is formed as shown in the equation.



(i) Name the by-product formed in the reaction.

.....[1]

(ii) Explain, in terms of oxidation state, whether ethanol is oxidised or reduced to form ethanal.

.....
.....
.....[2]

(c) Aldehydes can undergo addition reaction in which a molecule of hydrogen cyanide is added to form a cyanohydrin.

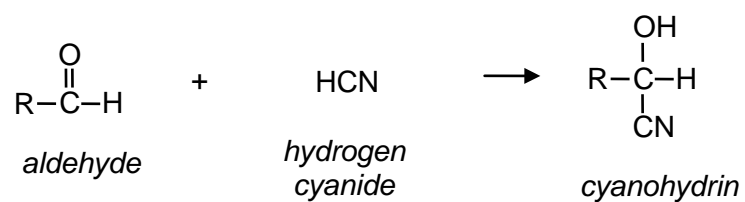

- (i) Draw the dot-and-cross diagram to represent a molecule of hydrogen cyanide. Show only valence electrons.

- (ii) Draw the full structural formula of the compound formed when ethanal reacts with hydrogen cyanide [2]

OR

B9 A soccer ball is typically made up of three parts: the outer covering, the inner lining and the bladder, which contains air.

Various polymers are used in the production of soccer balls. The diagram shows the different polymers which are used to form the different layers of a soccer ball.

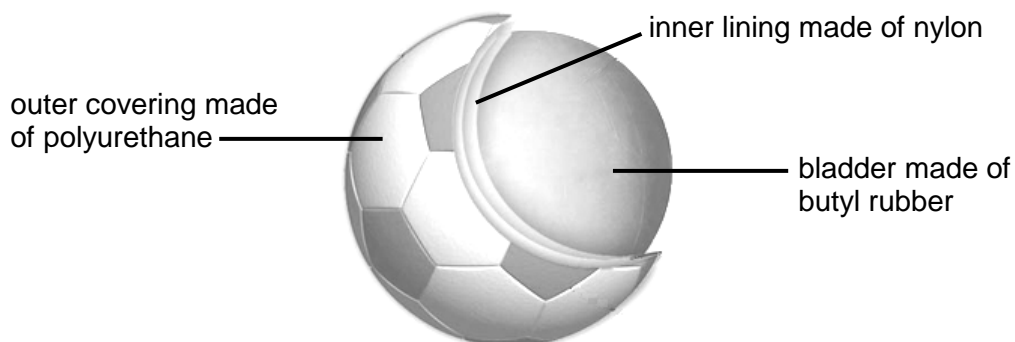

(a) Nylon is a condensation polymer. One type of nylon is nylon-6,6. This is the repeating unit of nylon-6,6.

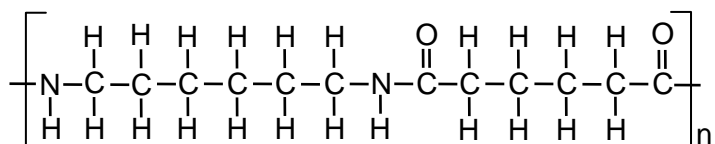

(i) What is meant by the term *condensation polymer*?

.....
.....[1]

(ii) Draw the structures of the two monomers that react to form nylon-6,6.

[2]

(iii) Name the linkage present in nylon-6,6.

.....[1]

- (b) Butyl rubber is a synthetic polymer which is produced by addition polymerisation of isobutylene. A section of the polymer is shown.

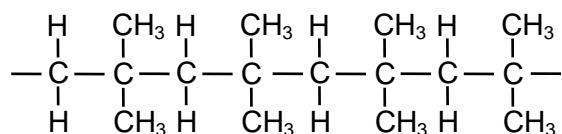

- (i) Draw the full structural formula of a molecule of isobutylene.

[1]

- (ii) Describe a test that can be used to differentiate isobutylene and butane.

.....

[2]

- (c) Polyurethanes are a group of compounds which contains the urethane linkage. The diagram shows the structure of the urethane linkage.

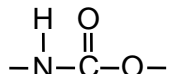

A urethane linkage is formed when a hydroxyl (alcohol) function group reacts with an isocyanate functional group shown in the diagram below.

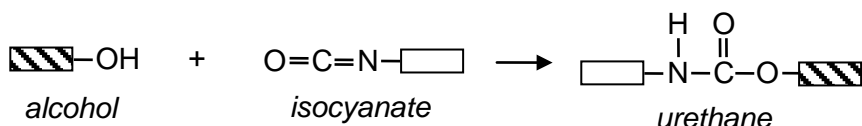

A type of polyurethane is formed by reacting these two monomers together in a ratio of 1:1.

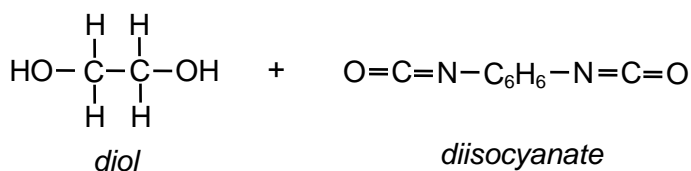

- (i) Draw a repeat unit of the polyurethane formed.

[1]

- (ii) A sample of the polyurethane was analysed and found to have an average relative molecular mass of 11 200.

How many carbon atoms are present in an average chain?

[2]

- END OF PAPER-

DATA SHEET
The Periodic Table of the Elements

		Group																	
I	II	III	IV	V	VI	VII	0												
7 Li Lithium 3	9 Be Beryllium 4	<table border="1" style="margin: auto; border-collapse: collapse;"> <tr> <td style="text-align: center;">1</td> <td style="text-align: center;">H Hydrogen 1</td> </tr> </table>										1	H Hydrogen 1	11 B Boron 5	12 C Carbon 6	14 N Nitrogen 7	16 O Oxygen 8	19 F Fluorine 9	20 Ne Neon 10
1	H Hydrogen 1																		
23 Na Sodium 11	24 Mg Magnesium 12	27 Al Aluminum 13	28 Si Silicon 14	31 P Phosphorus 15	32 S Sulfur 16	35.5 Cl Chlorine 17	40 Ar Argon 18												
39 K Potassium 19	40 Ca Calcium 20	45 Sc Scandium 21	48 Ti Titanium 22	51 V Vanadium 23	52 Cr Chromium 24	55 Mn Manganese 25	56 Fe Iron 26	59 Co Cobalt 27	59 Ni Nickel 28	64 Cu Copper 29	65 Zn Zinc 30	70 Ga Gallium 31	73 Ge Germanium 32	75 As Arsenic 33	79 Se Selenium 34	80 Br Bromine 35	84 Kr Krypton 36		
85 Rb Rubidium 37	88 Sr Strontium 38	89 Y Yttrium 39	91 Zr Zirconium 40	93 Nb Niobium 41	96 Mo Molybdenum 42	101 Ru Ruthenium 44	101 Rh Rhodium 45	103 Rh Rhodium 45	106 Pd Palladium 46	108 Ag Silver 47	112 Cd Cadmium 48	115 In Indium 49	119 Sn Tin 50	122 Sb Antimony 51	128 Te Tellurium 52	127 I Iodine 53	131 Xe Xenon 54		
133 Cs Cesium 55	137 Ba Barium 56	139 La Lanthanum 57	178 Hf Hafnium 72	181 Ta Tantalum 73	184 W Tungsten 74	190 Os Osmium 76	190 Ir Iridium 77	192 Ir Iridium 77	195 Pt Platinum 78	197 Au Gold 79	201 Hg Mercury 80	204 Tl Thallium 81	207 Pb Lead 82	209 Bi Bismuth 83	209 Po Polonium 84	209 At Astatine 85	210 Rn Radon 86		
226 Ra Radium 88	227 Ac Actinium 89																		

*58-71 Lanthanoid series
†90-103 Actinoid series

a	X
b	b

Key
 a = relative atomic mass
 X = atomic symbol
 b = proton (atomic) number

140 Ce Cerium 58	141 Pr Praseodymium 59	144 Nd Neodymium 60	146 Pm Promethium 61	150 Sm Samarium 62	152 Eu Europium 63	157 Gd Gadolinium 64	159 Tb Terbium 65	162 Dy Dysprosium 66	165 Ho Holmium 67	167 Er Erbium 68	169 Tm Thulium 69	173 Yb Ytterbium 70	175 Lu Lutetium 71
232 Th Thorium 90	232 Pa Protactinium 91	238 U Uranium 92	238 Np Neptunium 93	244 Pu Plutonium 94	244 Am Americium 95	247 Cm Curium 96	251 Bk Berkelium 97	259 Cf Californium 98	265 Es Einsteinium 99	267 Fm Fermium 100	269 Md Mendelevium 101	271 No Nobelium 102	277 Lr Lawrencium 103

The volume of one mole of any gas is 24 dm³ at room temperature and pressure (r.t.p.).

2016 Chem Prelims P1

1	2	3	4	5	6	7	8	9	10
B	C	C	D	A	B	C	D	C	D
11	12	13	14	15	16	17	18	19	20
D	A	C	C	D	D	D	A	C	C
21	22	23	24	25	26	27	28	29	30
B	D	C	B	B	B	C	A	A	B
31	32	33	34	35	36	37	38	39	40
B	A	D	A	D	D	D	C	A	D

Sec 4 Pure Chem Prelim 2016 Paper 2 mark scheme

Section A

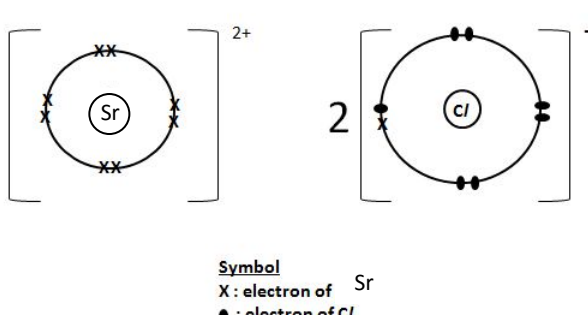
Qn	Answer	M
A1a	SiO ₂	1
A1b	Aluminium	1
A1c	Iron	1
A1d	Potassium/sodium/calcium/aluminium/magnesium	1
A1e	Oxygen is found in the earth's crust as it reacts with reactive metals to form solid compounds. [answers that refer to oxygen in the form of a gas are not accepted]	1
A2a	The colour of the solution changes from <u>green to red/orange</u> . There is a high concentration of <u>H⁺ ions</u> in the sample which makes the solution <u>acidic</u> .	1 1
A2bi	Precipitation/ filtration	1
A2bii	When aqueous ammonia is added to Zn ²⁺ ions, a white precipitate is formed and <u>can be removed by filtering</u> . However, if <u>excess aqueous ammonia</u> is added, the white precipitate will dissolve to form a colourless solution and cannot be removed. ["Zn ²⁺ ions are soluble in xs ammonia" were penalized as it is the precipitate that was soluble.]	1 1
A2biii	<u>Potassium ions (K⁺) and sodium ions (Na⁺)</u> cannot be removed As they form <u>soluble hydroxides</u> when reacted with aqueous ammonia.	1 1
A2c	Add <u>aqueous potassium iodide/chloride/sulfate</u> (any other possible reagents). Pb ²⁺ ions will react with aqueous potassium chloride to <u>form insoluble/solid lead(II) chloride</u> while can be <u>filtered away</u> . ["Aqueous chlorine" and "chlorine" was not accepted as there are no ions in it.]	1 1
A3a	Mg(OH) ₂ / MgO and H ₂ [No marks if equation was written instead.]	2
A3bi	Violently / Explosively ["Very explosively" is not accepted as this is a Group II metal.]	1
A3bii	Radium should be stored in oil/vacuum. ["inert environment" is not accepted unless candidates provide an example of what is meant by it.]	1
A3c	The <u>larger the atomic size, the more reactive</u> the element. (1) The <u>larger</u> the atom, the <u>further the valence electrons</u> from the nucleus. It is <u>easier to lose the valence electrons</u> (2) as the <u>attraction between negative electron and positive nucleus is weaker./ electrostatic forces of attraction is weaker.</u> (3)	1 1 1
A3di	 <p>Symbol X : electron of Sr ● : electron of Cl</p> <p>[candidates should either draw 2 chloride ions or ensure that the indication of the '2' cannot be ambiguous]</p>	2
A3dii	Strontium chloride has a <u>giant ionic lattice structure</u> (2) With strong electrostatic forces of attraction between ions that require a <u>large amount of energy to overcome</u> , (3) hence it is in the <u>solid state</u> . (1)	1 1 1
A4ai	Iron [note that iron metal should not have "(II)". Only ions or compounds will have it to show what	1

	is the oxidation state of iron, i.e. iron(II) ions or iron(II) oxide]																	
A4aii	Pink / brown / reddish-brown / pinkish-brown solid formed / metal decreases in size	1																
A4iii	$\text{Fe(s)} + \text{Cu}^{2+}(\text{aq}) \rightarrow \text{Fe}^{2+}(\text{aq}) + \text{Cu(s)}$ / $\text{M(s)} + \text{N}^{2+}(\text{aq}) \rightarrow \text{M}^{2+}(\text{aq}) + \text{N(s)}$ [State symbols are compulsory for all ionic equations]	1																
A4b	Insert burning splint into test tube. If burning splint extinguishes with " pop " sound, hydrogen gas is present.	1																
A4c	Z, X, Y	1																
A5a	V^{3+} acts as the <u>reducing agent</u> as causes Fe^{3+} to be <u>reduced</u> as Fe^{3+} <u>gains an electron to form Fe^{2+}</u> . [Answers that describe V^{3+} being oxidised to form V^{4+} are not accepted as it does not show how V^{3+} acts as a reducing agent]	1 1																
A5bi	<table border="1" style="width: 100%; border-collapse: collapse;"> <thead> <tr> <th></th> <th>V</th> <th>C</th> <th>N</th> </tr> </thead> <tbody> <tr> <td>%</td> <td>28</td> <td>33</td> <td>39</td> </tr> <tr> <td>No. of mol</td> <td>$28/51 = 0.549$</td> <td>$33/12 = 2.75$</td> <td>$39/14 = 2.78$</td> </tr> <tr> <td>Ratio</td> <td>$0.549/0.549 = 1$</td> <td>$2.75/0.549 = 5$</td> <td>$2.78/0.549 = 5$</td> </tr> </tbody> </table> Empirical formula of compound is V(CN)_5 . [" VC_5N_5 " is not accepted as the formula of polyatomic ion, CN^- is given.]		V	C	N	%	28	33	39	No. of mol	$28/51 = 0.549$	$33/12 = 2.75$	$39/14 = 2.78$	Ratio	$0.549/0.549 = 1$	$2.75/0.549 = 5$	$2.78/0.549 = 5$	1 1
	V	C	N															
%	28	33	39															
No. of mol	$28/51 = 0.549$	$33/12 = 2.75$	$39/14 = 2.78$															
Ratio	$0.549/0.549 = 1$	$2.75/0.549 = 5$	$2.78/0.549 = 5$															
A5bii	Oxidation state of vanadium is +5	1																
A5ci	$\text{Fe}_2\text{O}_3(\text{s}) + 3\text{CO}(\text{g}) \rightarrow 2\text{Fe(l)} + 3\text{CO}_2(\text{g})$ / $2\text{Fe}_2\text{O}_3(\text{s}) + 3\text{C}(\text{s}) \rightarrow 4\text{Fe(l)} + 3\text{CO}_2(\text{g})$ [1m for correct balanced equation; 1m for correct state symbols (after getting first mark)]	2																
A5cii	Limestone <u>decomposes</u> under high temperature to form <u>calcium oxide</u> . The <u>basic calcium oxide</u> reacts with the <u>acidic silicon dioxide</u> to form <u>calcium silicate / slag</u> <u>which is removed</u> . [Award only 1m if candidate provides both correct equations but not explanation.]	1 1																
A6a	From the <u>cracking</u> of hydrocarbons / <u>electrolysis</u> of water.	1																
A6b	Air contains oxygen which <u>may react with nitrogen or hydrogen gas to form oxides of nitrogen or water</u> in the hot reactor.	1																
A6c	<u>Condensation</u> can be used As ammonia has a <u>higher boiling point</u> than hydrogen and nitrogen. / As ammonia is able to remain as a liquid at -100°C^* while hydrogen and nitrogen are gases. (*use a reasonable temperature). [Fractional distillation is not accepted as the substances are all in the gaseous state.]	1 1																
A6d	Powdered iron is used as it has a <u>larger surface area</u> . The larger the <u>total exposed surface area</u> , (1)the higher the <u>frequency of effective collisions</u> <u>increase</u> (2) and <u>rate of reaction increases</u> . (3)	1 1 1																
A6ei	450atm, 350°C																	
A6eii	The process is <u>too dangerous/ costly</u> at 450atm and <u>too slow</u> at 350°C [No marks are awarded if candidates just state the ideal conditions or state facts like "at lower temperatures/when temperature is too low, the rate is too slow" without referencing the temperature.]	1 1																

Section B

Qn	Answer	M
B7a	ammonium chloride/ NH_4Cl	1
B7b	cathode: $2\text{NH}_4^+(\text{aq}) + 2\text{e}^- \rightarrow 2\text{NH}_3(\text{g}) + \text{H}_2(\text{g})$ anode: $\text{Zn}(\text{s}) \rightarrow \text{Zn}^{2+}(\text{aq}) + 2\text{e}^-$	1 1
B7c	<u>zinc case/base</u> is the anode which is <u>reacted</u> during the reaction. Hence, the thickness of the zinc case/base reduces, resulting in the leaking of the paste.	1
B7di	Oxygen	1
B7dii	silver is no longer deposited on the ring as	INCORRECT ANSWERS: 1

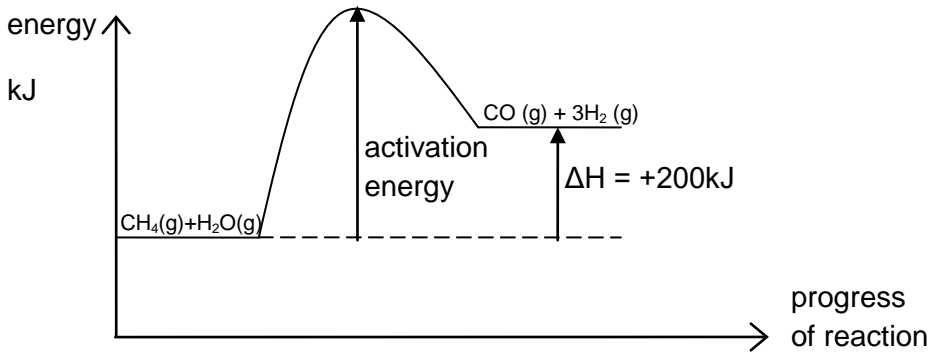
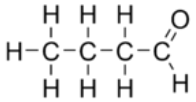
	the concentration of silver ions falls below the concentration in which it will be preferentially discharged/ all the silver ions are discharged/ There is no more silver ions in the solution	All silver ions are deposited All silver ions are displaced All the silver has reacted	
B7dii i	mass of silver deposited at the 10 th minute = 0.9 g no. of moles of silver deposited = 0.9/108 = 0.0083333 mol no. of moles of silver ions in the solution initially = 0.05 x 0.5 = 0.025 mol no. of moles of silver ions in the solution at the 10 th minute = 0.025 – 0.00833 = 0.016667 mol concentration of silver ions = 0.016667 /0.5 = 0.0333 mol/dm³		1 1 1
B7di v	$2\text{Ag}^+ \rightarrow 2\text{Ag} + 2\text{e}^-$ $\text{Zn} \rightarrow \text{Zn}^{2+} + 2\text{e}^-$ no. of moles of silver deposited = 0.0083333 mol no. of moles of zinc reacted = 0.0083333/2 = 0.0041667 mass of zinc reacted = 0.0041667 x 65 = 0.271g		1 1
B8a	enthalpy change = 4x415 + 2x464 – 1080 – 3x436 = +200kJ (must show positive sign)		1 1
B8b	 1 mark for shape of graph & labelling of reactants and products 1 mark for labelling of activation energy and ΔH (with one-sided arrow)		2
B8c	no. of moles of methane = 1000/16 = 62.5 no. of moles of hydrogen produced from SMR = 62.5 x 3 = 187.5 mol no. of moles of hydrogen produced from WGSR = 62.5 mol total no. of moles of hydrogen produced = 187.5 + 62.5 = 250 mol mass of hydrogen produced = 250 x 2 = 500g		1 1 1
B8d	$\text{C}_3\text{H}_8 + 3\text{H}_2\text{O} \rightarrow 3\text{CO} + 7\text{H}_2$ OR $\text{C}_3\text{H}_8 (\text{g}) + 3\text{H}_2\text{O} (\text{g}) \rightarrow 3\text{CO} (\text{g}) + 7\text{H}_2 (\text{g})$		1
B8e	<u>carbon dioxide is produced in the process of producing hydrogen during the water-gas shift reaction.</u>		1
EITHER			
B9ai	propanal $\text{C}_3\text{H}_7\text{CHO}$  3 correct – 2 marks 2 correct – 1 mark		2
B9aaii	They have the same <u>function group</u> " CHO " They have the same <u>general molecular formula</u> $\text{C}_n\text{H}_{2n+1}\text{CHO}$		1
B9aiii	$\text{C}_{17}\text{H}_{35}\text{CHO}$		1
B9bi	water		1
B9bii	ethanol is oxidised as the oxidation state of carbon increases from –2 in ethanol to –1 in ethanal		1 1

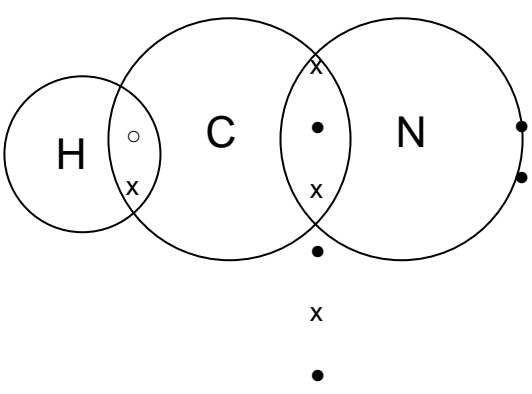
B9ci	 <p>lengend</p> <ul style="list-style-type: none"> • – electron of nitrogen ○ – electron of hydrogen x – electron of carbon <p>1 mark for diagram 1 mark for key (no marks if diagram is wrong)</p>	2
B9cii	$ \begin{array}{c} \text{H} \quad \text{O}-\text{H} \\ \quad \\ \text{H}-\text{C}-\text{C}-\text{H} \\ \quad \\ \text{H} \quad \text{C}\equiv\text{N} \end{array} $	1
OR		
B9ai	condensation polymer are <u>large molecules</u> formed when monomers combine <u>with the removal of a small molecule.</u>	1
B9aii	$ \begin{array}{cccccccc} & \text{H} & \text{H} & \text{H} & \text{H} & \text{H} & \text{H} & \\ & & & & & & & \\ \text{H} & -\text{N} & -\text{C} & -\text{C} & -\text{C} & -\text{C} & -\text{C} & -\text{N} & -\text{H} \\ & & & & & & & \\ & \text{H} & \text{H} & \text{H} & \text{H} & \text{H} & \text{H} & \text{H} \end{array} $	1
	$ \begin{array}{cccccccc} & \text{O} & \text{H} & \text{H} & \text{H} & \text{H} & \text{O} & \\ & & & & & & & \\ \text{HO} & -\text{C} & -\text{C} & -\text{C} & -\text{C} & -\text{C} & -\text{C} & -\text{OH} \\ & & & & & & & \\ & & \text{H} & \text{H} & \text{H} & \text{H} & & \end{array} $	1
B9aiii	amide linkage	1
B9bi	$ \begin{array}{c} \text{H} \\ \\ \text{H}-\text{C}-\text{H} \\ \\ \text{C}=\text{C} \\ \\ \text{H}-\text{C}-\text{H} \\ \\ \text{H} \end{array} $	1
B9bii	add aqueous bromine to a sample of isobutylene and butane separately. if aqueous bromine decolourises/turn from reddish-brown to colourless , the sample is isobutylene. if aqueous bromine remains reddish-brown , the sample is butane .	1 1
B9ci	$ \begin{array}{cccccccc} \text{O} & \text{H} & & \text{H} & \text{O} & & & \\ & & & & & & & \\ -\text{C} & -\text{N} & -\text{C}_6\text{H}_6 & -\text{N} & -\text{C} & -\text{O} & -\text{C} & -\text{C} & -\text{O}- \end{array} $	1
B9cii	no. of diol/diisocyanate molecules which reacted = $11200 / (62+162) = 50$ no. of carbon atoms in an average chain = $50 \times (2+8) = 500$	1 1