

*Visit*

**FREETESTPAPER.com**

*for more papers*



Website: [freetestpaper.com](http://www.freetestpaper.com)



[Facebook.com/freetestpaper](https://www.facebook.com/freetestpaper)



[Twitter.com/freetestpaper](https://www.twitter.com/freetestpaper)



CHIJ ST. THERESA'S CONVENT  
PRELIMINARY EXAMINATION 2017  
SECONDARY FOUR EXPRESS

CANDIDATE  
NAME

CLASS

INDEX  
NUMBER

**CHEMISTRY**

**5073/01**

Paper 1 Multiple Choice

18 September 2017

1 hour

Additional Materials: Multiple Choice Answer Sheet

**READ THESE INSTRUCTIONS FIRST**

Write in soft pencil.

Do not use staples, paper clips, glue or correction fluid.

Write your name, class and index number on the Answer Sheet in the spaces provided unless this has been done for you.

There are **forty** questions on this paper. Answer **all** questions. For each question, there are four possible answers **A, B, C** and **D**.

Choose the **one** you consider correct and record your choice in **soft pencil** on the separate Answer Sheet.

**Read the instructions on the Answer Sheet very carefully.**

Each correct answer will score one mark. A mark will not be deducted for a wrong answer.

Any rough working should be done in this booklet.

A copy of the Periodic Table is printed on page 16.

The use of an approved scientific calculator is expected, where appropriate.

This question paper consists of 16 printed pages.

2

- 1 The diagram below shows the distillation of a mixture of two liquids A and B.  
The liquid A has a boiling point of  $80^{\circ}\text{C}$  and the liquid B has a boiling point of  $110^{\circ}\text{C}$ .

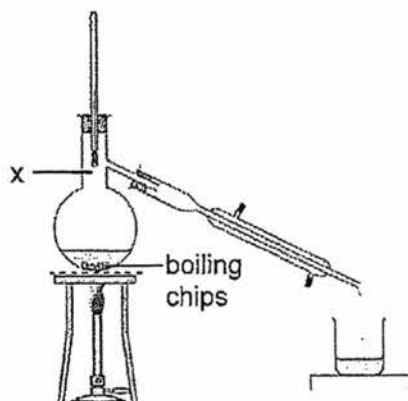

Which statement about the experiment is correct?

- A The boiling chips are added to increase the rate of reaction.  
B The liquid left in the flask contains more A than B.  
C The thermometer records a constant temperature as each liquid is collected.  
D The vapour at point X always contains more B than A.
- 2 The solubilities of three solids in water and tetrachloromethane are given in the table below.

solid	solubility in water	solubility in tetrachloromethane
sand	nil	nil
sodium chloride	good	nil
sulfur	nil	good

Which method would be suitable for obtaining pure sand from a mixture of sand, sodium chloride and sulfur?

- A Add tetrachloromethane and stir; then filter.  
B Add tetrachloromethane and stir; then filter, then add the residue to water and stir; and then filter this mixture and collect the residue.  
C Add water and stir; then filter; then evaporate the filtrate to dryness.  
D Add water and stir; then filter; then add tetrachloromethane to the filtrate and stir; then evaporate the solvent.

3

- 3 When a few drops of nitric acid and aqueous barium nitrate were added to a solution of substance C, a white precipitate was seen. When aqueous sodium hydroxide was added to solution of substance C, a white precipitate that was insoluble in excess sodium hydroxide was seen.

What could C be?

- A aluminium carbonate  
 B calcium sulfate  
 C lead(II) sulfate  
 D zinc chloride
- 4 An experiment was carried out on three gases, D, E and F, which have relative molecular masses of 17, 28 and 71 (not necessarily in the correct order).

gas	effect on damp litmus paper
D	no effect on blue and red litmus paper
E	turns damp blue litmus paper red, then white
F	turns damp red litmus paper blue

Which row correctly shows the order of the rates of diffusion of the three gases?

	slowest	→	fastest
A	D	E	F
B	E	D	F
C	E	F	D
D	F	D	E

- 5 Manganese sulfide, MnS is a pink solid that contains  ${}^{55}_{25}\text{Mn}^{2+}$  and  ${}^{32}_{16}\text{S}^{2-}$  ions.

How many **more** protons, neutrons and electrons are there in the  ${}^{55}_{25}\text{Mn}^{2+}$  ion as compared to the  ${}^{32}_{16}\text{S}^{2-}$  ion?

	protons	neutrons	electrons
A	9	14	5
B	9	14	9
C	9	23	9
D	11	23	9

4

- 6 Which statements correctly describe the properties of the compound copper(II) sulfide, CuS, and mixtures of copper and sulfur?

	compound copper(II) sulfide	mixtures of copper and sulfur
1	copper and sulfur react when heated to form copper(II) sulfide	copper and sulfur mix together without any heat energy absorbed or released
2	the ratio of copper to sulfur is always 1 : 1	the ratio of copper to sulfur in mixtures can vary
3	copper(II) sulfide has the same properties as copper and sulfur	the mixtures do not have the same properties as copper and sulfur

- A 1 only      B 1 and 2      C 2 and 3      D 1, 2, and 3
- 7 Which compound contains both ionic and covalent bonds?
- A ammonia  
B ethyl ethanoate  
C potassium nitrate  
D sodium chloride
- 8 The diagram below shows part of the structure of silicon carbide.

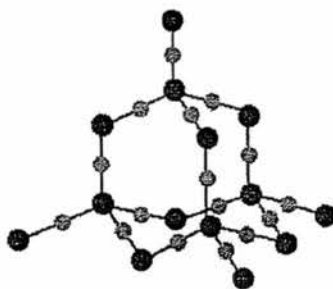

Which row correctly shows the properties of silicon carbide?

	electrical conductivity	when heated strongly in oxygen
A	good	burns, giving a solid residue only
B	good	burns, leaving no solid residue
C	poor	burns, giving a solid residue only
D	poor	burns, giving a solid residue and a colourless gas

5

- 9 Aluminium carbonate is an unstable compound, which decomposes readily to aluminium hydroxide and carbon dioxide.

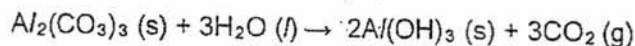

What is the percentage purity of a sample of impure aluminium carbonate if 351 g of the sample produces 36 dm<sup>3</sup> of carbon dioxide?

( $M_r$  of  $\text{Al}_2(\text{CO}_3)_3 = 234$ ,  $M_r$  of  $\text{CO}_2 = 44$ )

- A 13.6%  
 B 33.3%  
 C 54.5%  
 D 100.0%
- 10 Which of the information below is required to determine the empirical formula and molecular formula of a compound?
- 1 density of the compound
  - 2 percentage composition of the compound
  - 3 relative molecular mass of the compound
- A 1 only                      B 1 and 2                      C 2 and 3                      D 1, 2, and 3
- 11 Which substance has the highest percentage by mass of nitrogen?
- A  $\text{CO}(\text{NH}_2)_2$                        $M_r = 60$   
 B  $\text{NH}_4\text{NO}_3$                        $M_r = 80$   
 C  $(\text{NH}_4)_2\text{SO}_4$                        $M_r = 132$   
 D  $(\text{NH}_4)_3\text{PO}_4$                        $M_r = 149$

- 12 The diagram shows the results of an electrolysis experiment using graphite electrodes. Tubes A and B were filled with water at the start of the experiment.

Which could be substance X?

- A aqueous silver nitrate  
 B concentrated sodium chloride solution  
 C deionised water

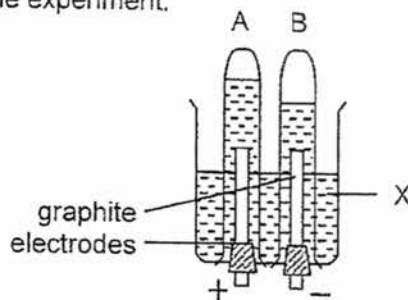

6

D dilute sulfuric acid

- 13 In an experiment, rods of copper and zinc are dipped into dilute sulfuric acid, with their top ends touching.

Hydrogen bubbles collect around the copper rod.

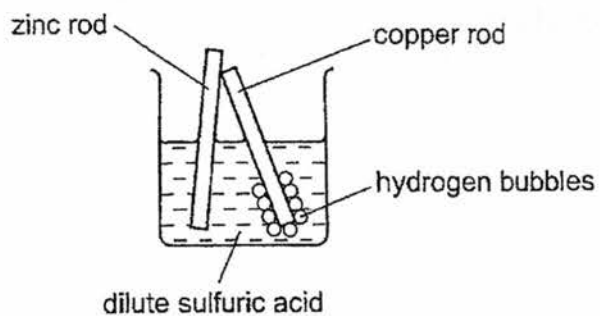

Which statement about the experiment is correct?

- A Copper reacts with the acid.  
 B Electrons flow from zinc to copper.  
 C The zinc becomes coated with copper.  
 D The zinc is less reactive than copper.
- 14 Which reaction profile shows the fastest exothermic reaction?

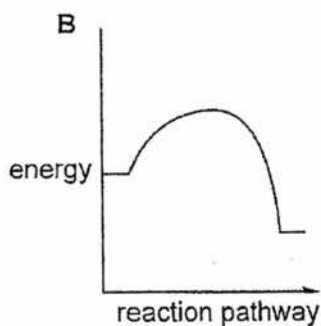
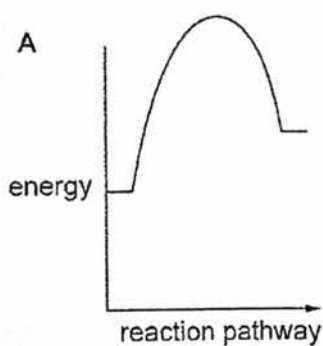

energy

7

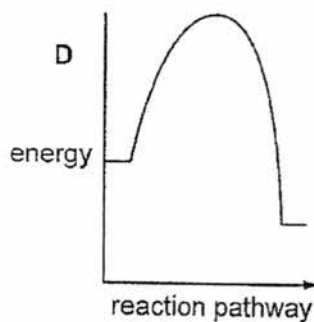
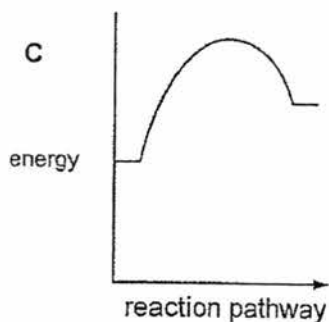

- 15 Which statement describes what happens when hydrogen and oxygen are used in a fuel cell?
- A Hydrogen is reduced.  
 B Electricity is generated directly.  
 C Hydrogen is burned to form steam.  
 D Hydrogen and oxygen react to produce hydrogen peroxide.

- 16 A student performs two reactions.

Reaction 1: 10 g of magnesium ribbon with excess 2.0 mol/dm<sup>3</sup> dilute hydrochloric acid

Reaction 2: 5 g of magnesium powder with excess 2.0 mol/dm<sup>3</sup> dilute hydrochloric acid

In both experiments, the volume of hydrogen produced,  $V$ , is measured against time,  $t$ .

Which set of graphs correctly shows the results obtained for the two experiments?

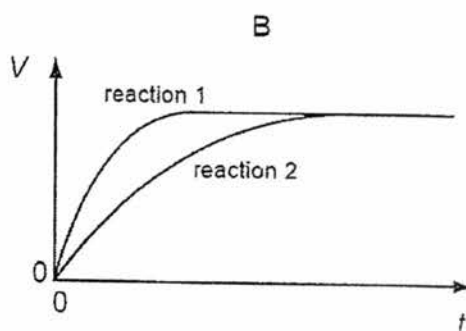
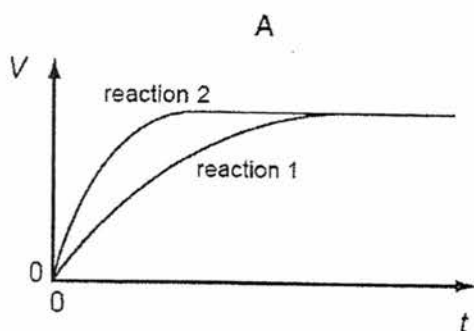

8

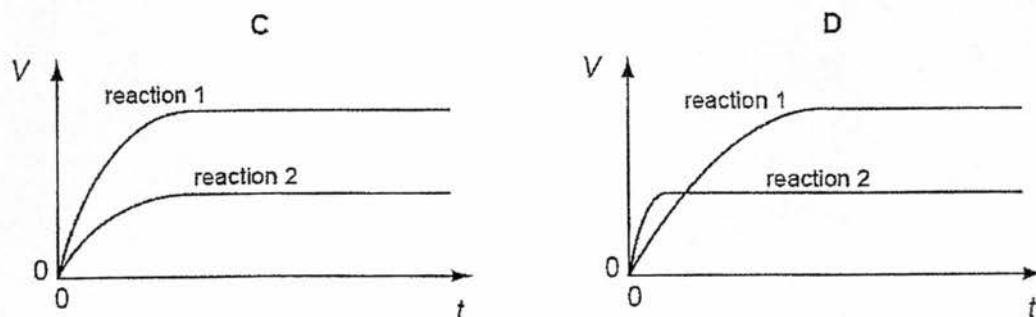

- 17 Which apparatus should the student use for the two experiments in Q16?
- P an electronic balance  
 Q a stopwatch  
 R a measuring cylinder  
 S a gas syringe
- A P, Q and R      B P, Q and S      C Q, R and S      D P, Q, R and S
- 18 Which reaction does not involve either oxidation or reduction?

- A  $\text{CH}_4(\text{g}) + 2\text{O}_2(\text{g}) \rightarrow \text{CO}_2(\text{g}) + 2\text{H}_2\text{O}(\text{g})$   
 B  $\text{Cu}^{2+}(\text{aq}) + \text{Zn}(\text{s}) \rightarrow \text{Cu}(\text{s}) + \text{Zn}^{2+}(\text{aq})$   
 C  $\text{CuO}(\text{s}) + \text{H}_2\text{SO}_4(\text{aq}) \rightarrow \text{CuSO}_4(\text{aq}) + \text{H}_2\text{O}(\text{l})$   
 D  $\text{Zn}(\text{s}) + \text{H}_2\text{SO}_4(\text{aq}) \rightarrow \text{ZnSO}_4(\text{aq}) + \text{H}_2(\text{g})$

- 19 Which statement correctly describes an acidic solution?
- A It contains hydrogen ions only.  
 B It contains more hydrogen ions than hydroxide ions.  
 C It turns blue cobalt chloride paper pink.  
 D It turns universal indicator blue.

- 20 Solid R is gradually added to aqueous solution S.  
 The changes in pH are shown on the graph below.

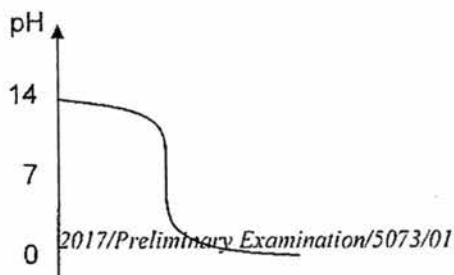

Setter: Mr Bryan Lim

9

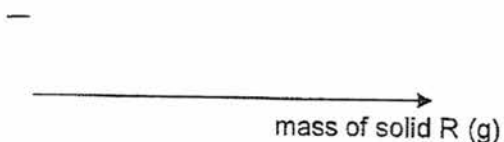

What are substances R and S?

	substance R	substance S
A	insoluble non-metal oxide	sodium hydroxide
B	soluble metal oxide	aqueous ammonia
C	soluble non-metal oxide	aqueous ammonia
D	soluble non-metal oxide	sodium hydroxide

- 21 Ammonia may be obtained from ammonium chloride by heating with
- A aqueous barium hydroxide.
  - B aqueous calcium chloride.
  - C dilute hydrochloric acid.
  - D water.
- 22 The diagram below shows apparatus used to measure the volume of hydrogen given off when an excess of dilute hydrochloric acid is added to powdered metal. The volume of gas is measured at room temperature and pressure.
-

10

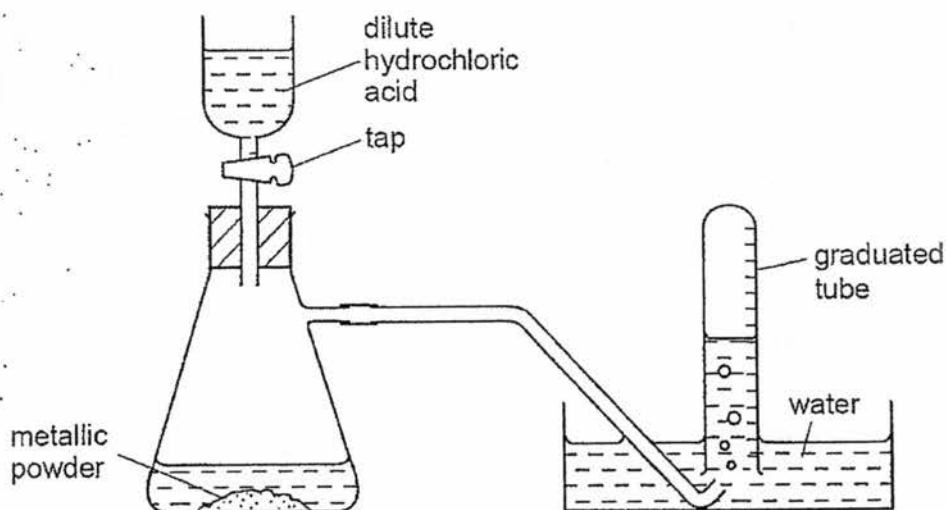

The experiment is carried out three times, using the same mass of powder each time but with different powders:

- pure calcium
- pure magnesium
- a mixture of calcium and magnesium

Which powder gives the greatest volume of hydrogen and which the least volume?

	greatest volume of $H_2$	least volume of $H_2$
A	pure calcium	pure magnesium
B	pure calcium	the mixture of calcium and magnesium
C	pure magnesium	pure calcium
D	pure magnesium	the mixture of calcium and magnesium

- 23 To reduce atmospheric pollution, the waste gases from a coal-burning power station are 'scrubbed' by passing them through a calcium compound.

Which calcium compound cannot be used?

- A calcium carbonate
- B calcium hydroxide
- C calcium oxide
- D calcium sulfate

- 24 Which element is likely to be sodium?
-

	melting point in °C	electrical conductivity	density in g / cm <sup>3</sup>
A	98	good	0.97
B	113	poor	2.07
C	1083	good	8.92
D	1535	good	7.86

- 25 The following report appeared in a newspaper.

Drums of bromine broke open after a vehicle crash on the motorway. Traffic was diverted as purple gaseous bromine drifted over the road (it is denser than air), causing irritation to drivers' eyes. Firemen sprayed water over the scene of the accident, dissolving the bromine and washing it away.

What is wrong with the report?

- A Bromine does not dissolve in water.  
 B Bromine does not vaporise easily.  
 C Bromine is less dense than air.  
 D Bromine is not purple in colour.
- 26 Which oxide is unlikely to dissolve in aqueous sodium hydroxide?
- A  $Al_2O_3$       B MgO      C  $P_4O_{10}$       D  $SO_2$
- 27 The exhaust systems of most cars are fitted with catalytic converters that contain transition metals as catalysts to decrease the emission of atmospheric pollutants. Platinum and palladium are the two most common elements used. They are found below nickel in the Periodic Table.
- Which properties are nickel, palladium and platinum likely to have in common?
- 1 variable oxidation states
  - 2 high melting points
  - 3 high density
- A 1 only      B 1 and 2      C 2 and 3      D 1, 2, and 3

28 Which statement correctly describes the elements in Group 0 of the Periodic Table?

- A All of their atoms have eight electrons in the outer shell.
- B They are colourful gases.
- C They are inert and unreactive.
- D They exist as diatomic molecules.

29 Some metals can be obtained by the reduction of their oxides with hydrogen.

Which line of the table is correct?

	aluminium	silver	copper	sodium
A	√	√	X	X
B	X	√	√	X
C	X	X	√	√
D	√	X	√	X

√ can be obtained by reduction of oxide with hydrogen

X cannot be obtained by reduction of oxide with hydrogen

30 In the extraction of iron, the role of carbon monoxide is

- A a catalyst.
- B a reducing agent.
- C an oxidising agent.
- D to remove impurities.

31 Oxygen was prepared from hydrogen peroxide and collected as shown in the diagram.

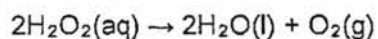

13

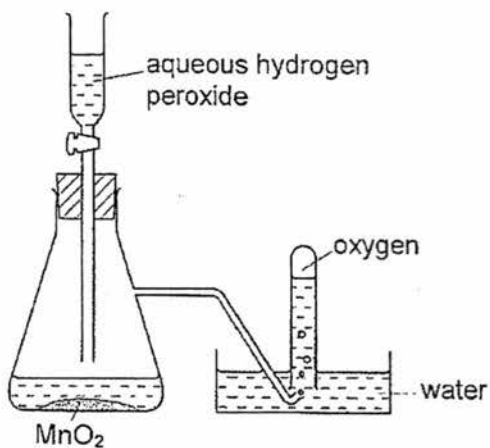

The first few tubes of gas were rejected because the gas was contaminated by

- A hydrogen.
- B hydrogen peroxide.
- C nitrogen.
- D water vapour.

32 The diagram shows the apparatus used for the fractional distillation of petroleum.

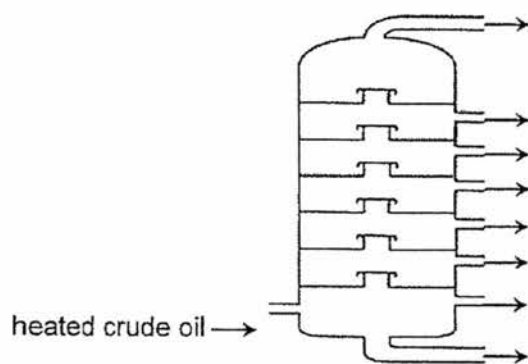

Which statement about the fractional distillation of petroleum is correct?

- A At each level, only one compound is collected.
  - B The higher up the column, the greater the temperature.
  - C The molecules collected at the bottom of the column are the least flammable.
  - D The molecules reaching the top of the column have the highest viscosity.
- 33 Linoleic acid,  $C_{17}H_{31}COOH$ , is the main fatty acid found in vegetable oils such as soybean oil and corn oil.

Which statement about linoleic acid is correct?

- A It burns in air with a non-smoky flame.
- B It is polyunsaturated as it contains many double bonds between carbon and hydrogen atoms.
- C It forms a solid compound on hydrogenation.
- D It produces margarine when it reacts with steam in the presence of nickel catalyst.

34 How many different alkenes have the molecular formula  $C_5H_{10}$ ?

- A 2                      B 3                      C 4                      D 5

35 The reaction between the hydrocarbon  $C_xH_6$  and hydrogen chloride can be represented by the equation below.

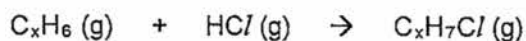

Which statement about the above reaction is true?

- A It is a substitution reaction.
  - B UV light is required for the reaction to take place.
  - C The molecular formula of the hydrocarbon is  $C_2H_6$ .
  - D The molecular formula of the hydrocarbon is  $C_3H_6$ .
- 36 An aqueous solution of a compound of formula,  $C_2H_4O_2$ , reacts with sodium carbonate liberating carbon dioxide.

What is the structural formula of the compound?

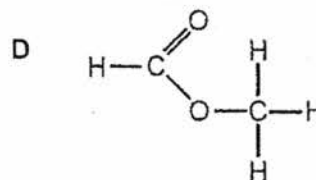
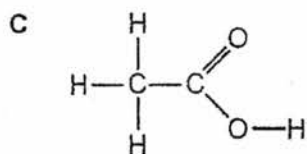
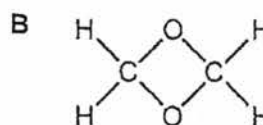
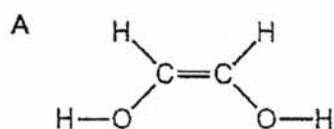

37 The following reaction scheme is carried out for the synthesis of a compound Z.

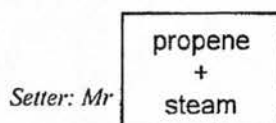

7023/2017/Preliminary Examination/5073/01

15

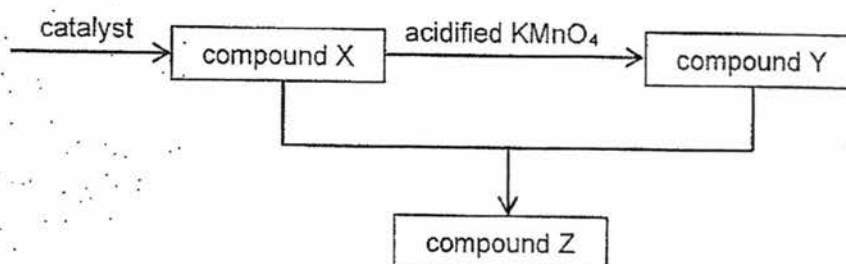

Which row correctly identifies compounds X, Y and Z?

	X	Y	Z
A	propanol	butanoic acid	propyl butanoate
B	propane	propanol	propanoic acid
C	propanoic acid	propanol	propyl propanoate
D	propanol	propanoic acid	propyl propanoate

- 38 Ethanoic acid containing a radioactive hydrogen atom ( $^3\text{H}$ ) was reacted with ethanol that contains a radioactive oxygen atom ( $^{18}\text{O}$ ) in the presence of concentrated sulfuric acid and heat.

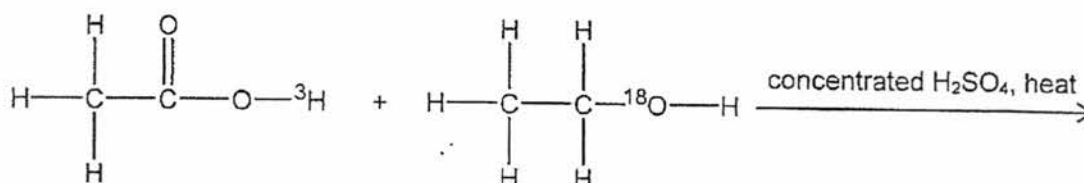

Which row correctly shows where the radioactive atoms will be found in the products?

	$^3\text{H}$	$^{18}\text{O}$
A	ester	ester
B	ester	water
C	water	ester
D	water	water

- 39 A polymer X is hydrolysed and the two products are

16

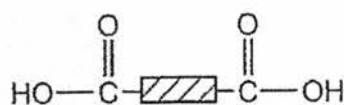

and

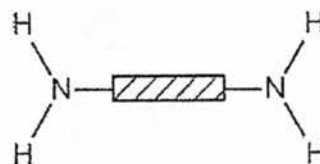

What can be deduced about X?

- A It is held by weak van der Waals forces of attraction.
  - B It is made by addition polymerisation.
  - C It is made by condensation polymerisation.
  - D It is *Terylene*.
- 40 In an artificial hip joint, bone cement is used to attach the poly(ethene) cup for the joint to the pelvic girdle.

Bone cement is formed by the polymerisation of 2-methylpropenoate and the process is highly exothermic.

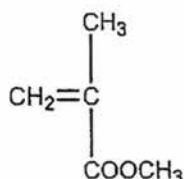

2-methylpropenoate

Which statements correctly describe this polymerisation?

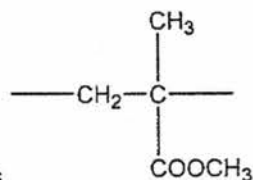

- I The repeat unit of the polymer is
  - II The formation of the cement occurs by addition polymerisation.
  - III The amount of energy released during bond making is less than the amount of energy absorbed during bond breaking.
- A I and II only
  - B I and III only
  - C II and III only
  - D I, II and III



**CHIJ ST. THERESA'S CONVENT  
PRELIMINARY EXAMINATION 2017  
SECONDARY FOUR EXPRESS**

CANDIDATE  
NAME

CLASS

INDEX  
NUMBER

**CHEMISTRY**

**5073/02**

Paper 2

13 September 2017

1 hour 45 minutes

Candidates answer on the Question Paper.

No Additional Materials are required.

**READ THESE INSTRUCTIONS FIRST**

Write your name, class and index number on all the work you hand in.

Write in dark blue or black pen.

You may use an HB pencil for any graphs.

Do not use staples, paper clips, glue or correction fluid.

**Section A**

Answer **all** questions in the spaces provided.

**Section B**

Answer **all** three questions, the last question is in the form either/or.

Answer **all** questions in the spaces provided.

At the end of the examination, fasten all your work securely together.

The number of marks is given in brackets [ ] at the end of each question or part question.

A copy of the Periodic Table is printed on page 20.

The use of an approved scientific calculator is expected, where appropriate.

For Examiner's Use	
Section A	
Section B	
Total	

This question paper consists of 20 printed pages.

## SECTION A

Answer all the questions in this paper in the spaces provided.  
The total mark for this section is 50.

A1 The Periodic Table shows trends down each group and across each period.

- (a) Which trends are only true down a group, which trends are only true across a period, which trends are true for both, and which trends are not true for both?

Put a tick (✓) in **one** box in each row.

trend	only true down a group	only true across a period	true for both	not true for both
The mass number increases.				
The atomic radius increases.				
The melting point increases.				
There is a change in the character of the oxides from basic to amphoteric to acidic.				

[2]

- (b) Group I and Group VII show different trends in their properties.

Group I	Group VII
Li	F
Na	Cl
K	Br
Rb	I

- (i) Explain the trend in reactivity down each group.

.....

.....

.....

..... [3]

- (ii) Hydrogen is not placed in any group of the Periodic Table though it shares some similar properties with the elements in Group I and the elements in Group VII.

Give reasons to explain why hydrogen can be placed in either Group I or Group VII of the Periodic Table.

Group I .....

.....

Group VII .....

.....

[2]

- (c) Persulfate ions,  $S_2O_8^{2-}$  oxidise iodide ions according to the following equation.

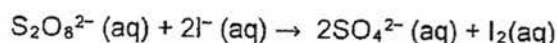

The reaction occurs very slowly at room temperature, so a catalyst of  $Fe^{2+}$  ions is used.

The reaction involving the  $Fe^{2+}$  catalyst takes place in two steps:

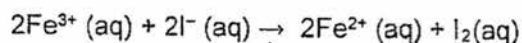
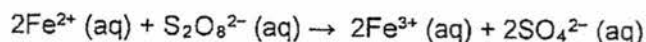

- (i) With reference to the collision of particles, suggest why the reaction between persulfate ions and iodide ions is very slow at room temperature.

.....

..... [1]

- (ii) Using the above equations, explain how the  $Fe^{2+}$  ion displays one of the characteristics of a catalyst.

.....

..... [1]

- (iii) Using information from the above equations, suggest the property of transition metals that allow  $Fe^{2+}$  to act as a catalyst in this reaction.

.....

..... [1]

[Total: 10]

- A2 (a) Iron is probably the most widely used and most important metal in the world today. One problem with using iron is that it rusts.

The diagram below shows an experiment carried out to investigate different rust prevention methods. An iron nail is placed in each of the four test tubes, A, B, C, and D. A ferroxyl indicator is used to indicate when rusting has taken place. When the colour of the ferroxyl indicator changes from yellow to blue, this indicates that rusting has taken place.

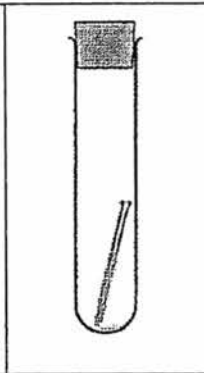
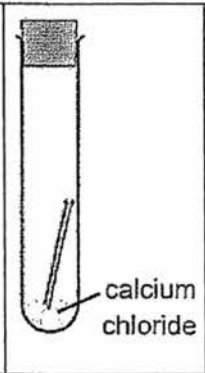
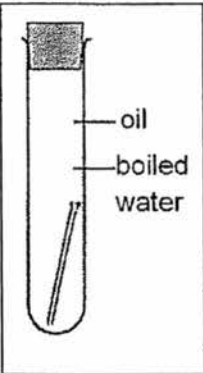
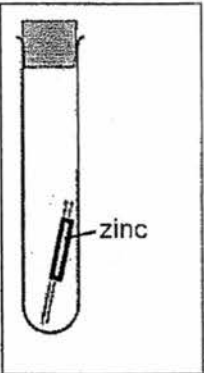
				
test tube	A	B	C	D
observation	indicator turns blue	indicator remains yellow	indicator remains yellow	

- (i) Explain the observations seen in test tubes A, B and C.

.....

.....

.....

..... [3]

- (ii) In test tube D, a piece of zinc metal is attached to the iron nail.

Suggest with a reason, the observation that would be made in the test tube after some time.

.....

.....

.....

..... [3]

(b) Iron alloys are widely used in the industry.

(i) Using a named example of an iron alloy, explain what is meant by the term *alloy*.

.....  
 .....  
 ..... [2]

(ii) Using your example named in (i), state and explain one advantage of the alloy over the pure metal(s).

.....  
 .....  
 ..... [2]

[Total: 10]

A3 Figure 1 shows the composition of elements in the Earth's crust.  
 Table 1 shows the year of discovery and cost per tonne of some metals.

Figure 1: Elemental composition of the Earth's crust by mass

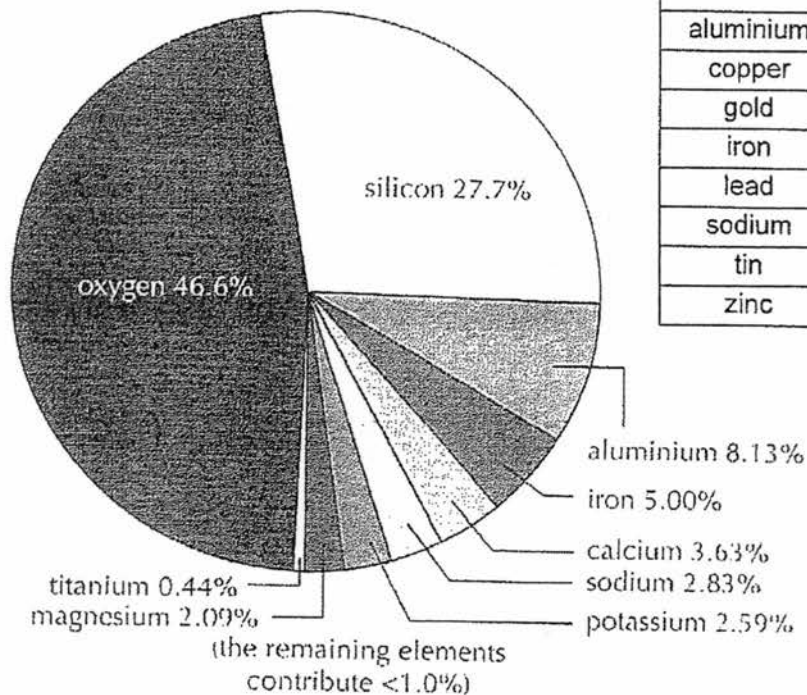

Table 1

Metal	Year of discovery	Cost per tonne / S\$
aluminium	1827	2,500
copper	4200 BC	10,000
gold	6000 BC	50,000,000
iron	1500 BC	5,500
lead	3500 BC	2,500
sodium	1807	3,500
tin	1750 BC	25,000
zinc	1400	2,400

6

- (a) Most metals are commonly found as ores. Using the information in Figure 1, which element is most likely to be found combined with metals?  
 ..... [1]
- (b) Using the information in Figure 1, suggest the most common compound found in the Earth's crust.  
 ..... [1]
- (c) Using your knowledge of the reactivity series, suggest the relationship between the year of discovery of the metals and the reactivity of the metals in Table 1.  
 ..... [1]
- (d) Using the information in Figure 1, suggest why it is costly to produce copper and tin.  
 ..... [1]
- (e) Which metals found in Table 1 were most likely isolated and discovered by electrolysis? Give a reason for your answer.  
 .....  
 ..... [2]
- (f) Suggest with a reason, why aluminium is discovered later than sodium despite sodium being more reactive than aluminium.  
 .....  
 ..... [1]

[Total: 7]

A4 PotashCorp is the world's largest producer of fertilisers, most of which are made from salts.

(a) The company reacts acids with other compounds to make the salts.

The table below shows the names of some salts used in fertilisers.

Salts can be prepared by either of the following methods:

- (i) titration
- (ii) reaction of acid with excess metal, base or metal carbonate
- (iii) precipitation

Complete the table by filling in the missing information.

name of salt	formula of salt	name of acid used to make salt	name of other compound used to make salt	method of preparation (i), (ii) or (iii)
potassium nitrate				
calcium phosphate (insoluble in water)				
ammonium chloride				

[6]

(b) Using your answers in (a), describe briefly how a pure dry sample of potassium nitrate can be obtained.

.....

.....

.....

.....

.....

.....

..... [4]

8

- (c) State one physical property of potassium nitrate.

Explain this property in terms of the structure and bonding of potassium nitrate.

.....

.....

..... [2]

- (d) Each bag of fertiliser has a label which gives the N : P : K ratio.

The N : P : K ratio shows the ratio by mass of nitrogen, phosphorus and potassium in the fertiliser, and is always quoted as whole numbers.

Determine the N : P : K ratio for each of the salts in the table below.

name of salt	N : P : K ratio
potassium nitrate	
calcium phosphate	
ammonium chloride	

[2]

[Total: 12]

- A5 (a) Ketones are a homologous series of organic compounds.

The table shows the names, formulae and boiling points of some ketones.

name	structural formula	boiling point / °C
2-propanone	$\begin{array}{c} \text{O} \\    \\ \text{CH}_3 - \text{C} - \text{CH}_3 \end{array}$	56
2-butanone	$\begin{array}{c} \text{O} \\    \\ \text{CH}_3 - \text{C} - \text{CH}_2 - \text{CH}_3 \end{array}$	80
3-pentanone	$\begin{array}{c} \text{O} \\    \\ \text{CH}_3 - \text{CH}_2 - \text{C} - \text{CH}_2 - \text{CH}_3 \end{array}$	
3-hexanone	$\begin{array}{c} \text{O} \\    \\ \text{CH}_3\text{CH}_2 - \text{C} - \text{CH}_2\text{CH}_2\text{CH}_3 \end{array}$	123

- (i) Deduce the general formula and functional group of the ketone homologous series

general formula ..... functional group ..... [2]

- (ii) Predict the boiling point of 3-pentanone.

..... [1]

- (iii) Using the information above, deduce the significance of the number "3" in the name "3-hexanone".

..... [1]

- (iv) 2-propanone, propanal (an aldehyde) and 2-propanol are all compounds of carbon, hydrogen and oxygen.

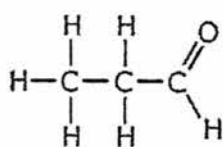

propanal

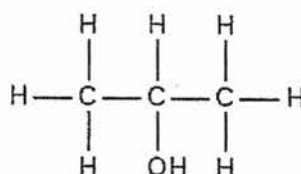

2-propanol

State with reasons, which of these three compounds are isomers of each other.

.....  
 .....  
 ..... [2]

- (b) Ketones can be made by the oxidation of some alcohols.  
 For example, 2-propanone can be formed from the oxidation of 2-propanol.

- (i) State a suitable oxidising agent that can be used for the oxidation of 2-propanol to 2-propanone, and the observation that would be made during this reaction.

.....  
 ..... [2]

- (ii) Write an equation for the oxidation of 2-propanol to 2-propanone.  
 Show the organic compounds as displayed formulae.

[1]

[Total: 9]

## SECTION B (30 marks)

Answer all **three** questions from this section.

The last question is in the form of an either/or and only one of the alternatives should be attempted.

## B6 Chemical Kinetics

Chemical kinetics is the study of the rate (or speed) of reactions and the factors that affect them.

In general, when the concentration of a reactant increases, the rate of the reaction increases. However, the rate of the reaction may not always be directly proportional to the concentration of each of the reactants in the reaction.

The rate of a reaction can be defined as the rate of increase in concentration of a product with time or the rate of decrease in concentration of a reactant with time.

## Rate Law

The rate law or rate equation provides information on how the rate of a reaction depends on the concentration of all the reactants.

Consider the reaction:  $a A + b B \rightarrow \text{products}$

where  $a$  and  $b$  are the stoichiometric coefficients and  $A$  and  $B$  are the reactants.

The rate equation or rate law can be expressed as:

$$\text{Rate} = k [A]^m [B]^n$$

where  $k$  is a constant of proportionality in the rate equation.

$m$  is the order of reaction with respect to reactant A

$n$  is order of reaction with respect to reactant B

## Order of reaction

The order of reaction with respect to a given reactant is defined as the power to which the concentration of that reactant is raised to in the rate equation.

A reaction is said to be zero order with respect to a particular reactant, e.g. A, if the rate of reaction does not depend on the concentration of A.

$$\text{rate} \propto [A]^0 \quad \text{where } [A] \text{ represents the concentration of A}$$

Hence,  $\text{rate} = k [A]^0 = k$  where  $k$  is the proportionality constant

A reaction is said to be first order with respect to a particular reactant, e.g. B, if the rate of reaction is directly proportional to the concentration of B.

$$\text{rate} \propto [\text{B}]^1 \quad \text{where } [\text{B}] \text{ represents the concentration of B}$$

Hence,  $\text{rate} = k [\text{B}]^1 = k [\text{B}]$  where  $k$  is the proportionality constant

A reaction is said to be second order with respect to a particular reactant, e.g. C, if the rate of reaction is directly proportional to the square of the concentration of C.

$$\text{rate} \propto [\text{C}]^2 \quad \text{where } [\text{C}] \text{ represents the concentration of C}$$

Hence,  $\text{rate} = k [\text{C}]^2 = k [\text{C}]^2$  where  $k$  is the proportionality constant

### Overall Order of a Reaction

The overall order of a reaction is the sum of the orders of reaction of all the reactants.

For example, if the rate equation for a reaction is

$$\text{Rate} = k [\text{A}]^m [\text{B}]^n$$

The overall order of the reaction is  $(m + n)$ .

### Hydrolysis of halogenoalkanes

Halogenoalkanes can react with aqueous sodium hydroxide upon warming to produce alcohols and the respective hydrogen halides. This is known as a hydrolysis reaction.

For example,  $\text{CH}_3\text{Br} (\text{aq}) + \text{NaOH} (\text{aq}) \rightarrow \text{CH}_3\text{OH} (\text{aq}) + \text{HBr} (\text{aq})$

The results of an investigation into the kinetics of this reaction are given below:

experiment number	$[\text{CH}_3\text{Br}] / \text{mol dm}^{-3}$	$[\text{NaOH}] / \text{mol dm}^{-3}$	initial rate of reaction / $\text{mol dm}^{-3} \text{s}^{-1}$
1	0.10	0.20	0.001
2	0.20	0.10	0.001
3	0.20	0.20	0.002
4	0.30	0.20	0.003
5	0.60	0.40	0.012

The data collected in the table can then be analysed and processed to give information about the kinetics of the hydrolysis reaction between bromomethane and aqueous sodium hydroxide.

- (a) Use the information in the table to deduce the order of reaction with respect to  $\text{CH}_3\text{Br}$ . Explain your reasoning.

[1]

- (b) Use the information in the table to deduce the order of reaction with respect to  $\text{NaOH}$ . Explain your reasoning.

[1]

- (c) What is the overall order of the reaction between bromomethane and aqueous sodium hydroxide?

.....[1]

- (d) Write an overall rate equation for the reaction between bromomethane and aqueous sodium hydroxide.

.....[1]

- (e) Determine the value and unit for the rate constant,  $k$ , in your rate equation in (d).

.....

.....[1]

- (f) The reactants and products for the reaction between bromomethane and aqueous sodium hydroxide are all colourless.

Describe a chemical test that can be carried out on the product(s) to confirm that the reaction has occurred. Include the observation(s) that would be made for a positive test.

.....

.....

.....[2]

- (g) A dibromoalkane W ( $M_r = 188$ ), is warmed with excess aqueous sodium hydroxide to produce a diol X. The diol is then oxidised fully to a dicarboxylic acid Y. Under suitable conditions, diol X and dicarboxylic acid Y can react to form a polymer Z.

Deduce the identities of W, X, Y and Z.

[4]

[Total: 11]

- B7 Hydrazine is a compound often used in rocket fuels as it can be stored conveniently in liquid form, reacts exothermically with oxygen, and produces only gaseous products in the process.

The reaction of hydrazine with oxygen (Reaction I) can be expressed as follows:

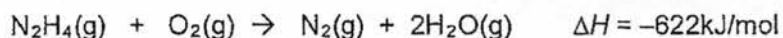

It has been suggested that the reaction between hydrazine and fluorine (Reaction II) is more exothermic than that between hydrazine and oxygen.

#### Reaction II

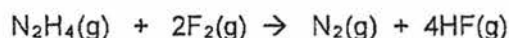

Bond energy is the energy released when a bond is formed between two atoms or the energy required to break a bond between two atoms.

The following table shows the bond energies of selected covalent bonds, measured in kilojoules per mole.

bond	bond energy in kJ/mol
F – F	158
N – N	160
N – H	390
H – F	565
N = N	418
N ≡ N	945

- (a) Draw a dot-and-cross diagram to show the covalent bonding in hydrazine. Show outer shell electrons only.

[2]

- (b) Using the bond energies given above,

- (i) calculate the amount of energy (kJ) required to break all the bonds in the reactants in Reaction II;

[1]

15

- (ii) calculate the amount of energy (kJ) released when all the bonds are formed in the products in Reaction II;

[1]

- (iii) calculate  $\Delta H$  for Reaction II.

[1]

- (c) Which gas, oxygen or fluorine, would be a better oxidant for the hydrazine in rocket fuel? Give a reason for your answer.

.....  
 ..... [1]

- (d) Draw an energy profile diagram for the reaction between hydrazine and oxygen. On your diagram label the product(s), activation energy,  $E_a$ , and enthalpy change for the reaction,  $\Delta H$ .

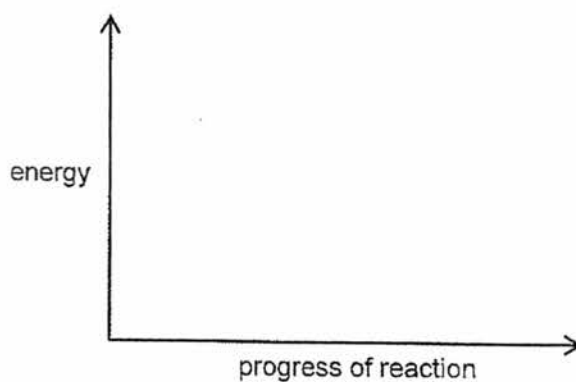

[2]

- (e) Dinitrogen tetroxide ( $N_2O_4$ ) is sometimes added to hydrazine in rocket fuels. Oxides of nitrogen are obtained as waste products.

Explain why this can be harmful to the environment.

.....  
 ..... [1]

[Total: 9]

## EITHER

B8 The Haber process for making ammonia can be represented by the flow diagram below.

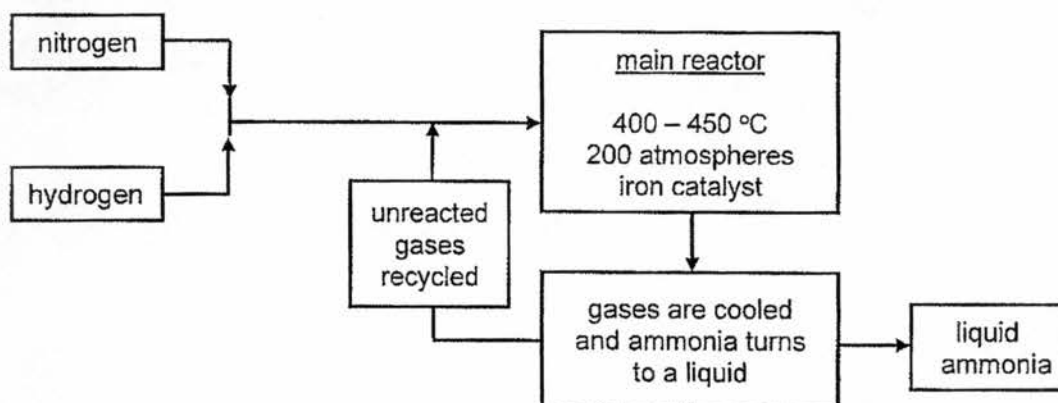

(a) State how nitrogen and hydrogen can be obtained for the making of ammonia.

nitrogen ..... hydrogen .....

[2]

(b) Which element is reduced in the reaction?

Use ideas about changes in oxidation state to explain your answer.

.....

.....[1]

(c) The graph shows the yield of ammonia that is made under different conditions.

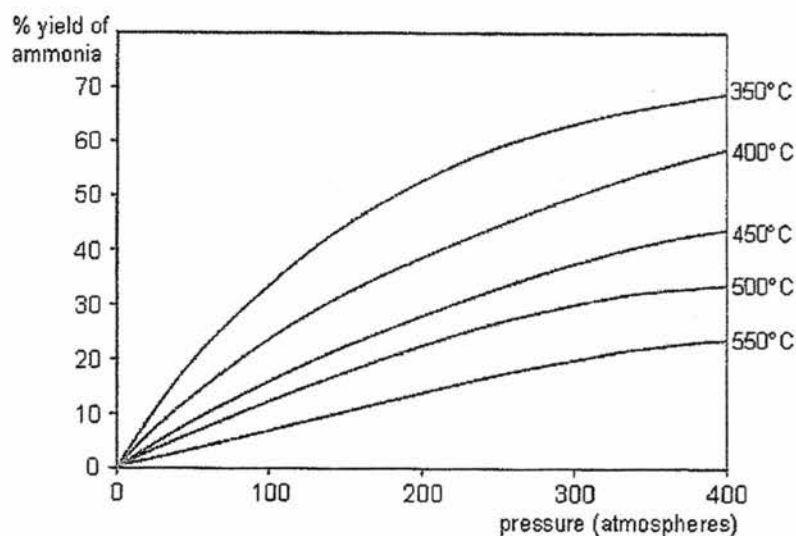

- (i) Explain, in terms of collisions between (reacting) particles, how a higher temperature affects the rate of reaction in the reactor.
- .....
- .....
- .....
- .....[2]
- (ii) Using the information in the graph, state the conditions that would produce the highest yield of ammonia.
- .....[1]
- (iii) What effect does the iron catalyst have on the yield of ammonia obtained? Explain your reasoning.
- .....
- .....
- .....[2]
- (iv) Explain why the unreacted gases obtained from the main reactor are recycled.
- .....
- .....[1]
- (v) In practice, it is not possible to obtain 100% yield of ammonia in the Haber process. Explain why this is so.
- .....
- .....[1]

[Total: 10]

OR

B8 Lead(II) nitrate and copper(II) chloride are both soluble salts.

The diagram shows the apparatus that a student used to electrolyse aqueous solutions of the salts.

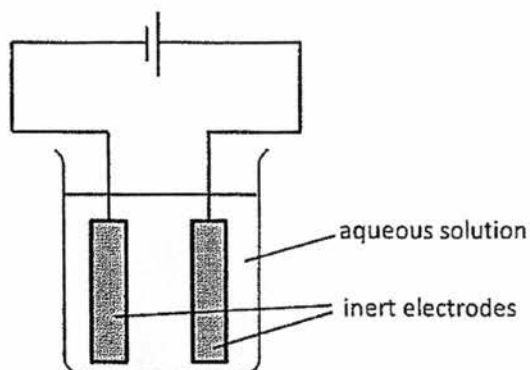

(a) Complete the table of information about the electrolysis.

solution	name of products of electrolysis		ionic equation for reaction at each electrode
dilute aqueous lead(II) nitrate	at negative electrode		
	at positive electrode		
concentrated aqueous copper(II) chloride	at negative electrode		
	at positive electrode		

[4]

(b) Complete the table below to show the observations that would be made during the electrolysis.

solution	observations	
dilute aqueous lead(II) nitrate	at negative electrode	
	at positive electrode	
	in electrolyte	
concentrated aqueous copper(II) chloride	at negative electrode	
	at positive electrode	
	in electrolyte	

[3]

- (c) 20 cm<sup>3</sup> of 0.5 mol dm<sup>-3</sup> aqueous lead(II) nitrate was mixed with 15 cm<sup>3</sup> of 0.8 mol dm<sup>-3</sup> aqueous copper(II) chloride.

Calculate the maximum mass of precipitate that can be obtained.

[3]

[Total: 10]

**DATA SHEET**  
**The Periodic Table of the Elements**

I	II	III	
3 <b>Li</b> lithium 7	4 <b>Be</b> beryllium 9	5 <b>B</b> boron 11	6 <b>C</b> carbon 12
11 <b>Na</b> sodium 23	12 <b>Mg</b> magnesium 24	13 <b>Al</b> aluminium 27	14 <b>Si</b> silicon 28
19 <b>K</b> potassium 39	20 <b>Ca</b> calcium 40	21 <b>Sc</b> scandium 45	22 <b>Ti</b> titanium 48
37 <b>Rb</b> rubidium 85	38 <b>Sr</b> strontium 88	39-71 <b>Y</b> yttrium 89	40 <b>Zr</b> zirconium 91
55 <b>Cs</b> caesium 133	56 <b>Ba</b> barium 137	57-71 lanthanoids	72 <b>Hf</b> hafnium 178
87 <b>Fr</b> francium -	88 <b>Ra</b> radium -	89-103 actinoids	104 <b>Rf</b> Rutherfordium -
			23 <b>V</b> vanadium 51
			24 <b>Cr</b> chromium 52
			25 <b>Mn</b> manganese 55
			26 <b>Fe</b> iron 56
			27 <b>Co</b> cobalt 59
			28 <b>Ni</b> nickel 59
			29 <b>Cu</b> copper 64
			30 <b>Zn</b> zinc 65
			31 <b>Ga</b> gallium 70
			41 <b>Nb</b> niobium 93
			42 <b>Mo</b> molybdenum 96
			43 <b>Tc</b> technetium -
			44 <b>Ru</b> ruthenium 101
			45 <b>Rh</b> rhodium 103
			46 <b>Pd</b> palladium 106
			47 <b>Ag</b> silver 108
			48 <b>Cd</b> cadmium 112
			49 <b>In</b> indium 115
			50 <b>Sn</b> tin 119
			51 <b>Sb</b> antimony 122
			52 <b>Te</b> tellurium 128
			53 <b>I</b> iodine 127
			54 <b>Xe</b> xenon 136
			55 <b>Ba</b> barium 137
			56 <b>La</b> lanthanum 139
			57 <b>Ce</b> cerium 140
			58 <b>Pr</b> praseodymium 141
			59 <b>Nd</b> neodymium 144
			60 <b>Pm</b> promethium -
			61 <b>Sm</b> samarium 150
			62 <b>Eu</b> europium 152
			63 <b>Gd</b> gadolinium 157
			64 <b>Tb</b> terbium 159
			65 <b>Dy</b> dysprosium 162
			66 <b>Ho</b> holmium 165
			67 <b>Er</b> erbium 167
			68 <b>Tm</b> thulium 169
			69 <b>Yb</b> ytterbium 173
			70 <b>Lu</b> lutetium 175
			71 <b>Hf</b> hafnium 178
			72 <b>Ta</b> tantalum 181
			73 <b>W</b> tungsten 184
			74 <b>Re</b> rhenium 186
			75 <b>Os</b> osmium 190
			76 <b>Ir</b> iridium 192
			77 <b>Pt</b> platinum 195
			78 <b>Au</b> gold 197
			79 <b>Hg</b> mercury 201
			80 <b>Tl</b> thallium 204
			81 <b>Pb</b> lead 207
			82 <b>Bi</b> bismuth 209
			83 <b>Po</b> polonium -
			84 <b>At</b> astatine -
			85 <b>Rn</b> radon -
			86 <b>Ra</b> radium -
			87 <b>Fr</b> francium -
			88 <b>Ra</b> radium -
			89 <b>Ac</b> actinium -
			90 <b>Th</b> thorium 232
			91 <b>Pa</b> protactinium -
			92 <b>U</b> uranium 238
			93 <b>Np</b> neptunium -
			94 <b>Pu</b> plutonium -
			95 <b>Am</b> americium -
			96 <b>Cm</b> curium -
			97 <b>Bk</b> berkelium -
			98 <b>Cf</b> californium -
			99 <b>Es</b> einsteinium -
			100 <b>Fm</b> fermium -
			101 <b>Mn</b> manganese -
			102 <b>Fe</b> iron -
			103 <b>Co</b> cobalt -
			104 <b>Ni</b> nickel -
			105 <b>Cu</b> copper -
			106 <b>Zn</b> zinc -
			107 <b>Ga</b> gallium -
			108 <b>Ge</b> germanium -
			109 <b>As</b> arsenic -
			110 <b>Se</b> selenium -
			111 <b>Br</b> bromine -
			112 <b>Kr</b> krypton -
			113 <b>Rb</b> rubidium -
			114 <b>Sr</b> strontium -
			115 <b>Y</b> yttrium -
			116 <b>Zr</b> zirconium -
			117 <b>Nb</b> niobium -
			118 <b>Mo</b> molybdenum -
			119 <b>Tc</b> technetium -
			120 <b>Ru</b> ruthenium -
			121 <b>Rh</b> rhodium -
			122 <b>Pd</b> palladium -
			123 <b>Ag</b> silver -
			124 <b>Cd</b> cadmium -
			125 <b>In</b> indium -
			126 <b>Sn</b> tin -
			127 <b>Sb</b> antimony -
			128 <b>Te</b> tellurium -
			129 <b>I</b> iodine -
			130 <b>Xe</b> xenon -
			131 <b>Ba</b> barium -
			132 <b>La</b> lanthanum -
			133 <b>Ce</b> cerium -
			134 <b>Pr</b> praseodymium -
			135 <b>Nd</b> neodymium -
			136 <b>Pm</b> promethium -
			137 <b>Sm</b> samarium -
			138 <b>Eu</b> europium -
			139 <b>Gd</b> gadolinium -
			140 <b>Tb</b> terbium -
			141 <b>Dy</b> dysprosium -
			142 <b>Ho</b> holmium -
			143 <b>Er</b> erbium -
			144 <b>Tm</b> thulium -
			145 <b>Yb</b> ytterbium -
			146 <b>Lu</b> lutetium -
			147 <b>Hf</b> hafnium -
			148 <b>Ta</b> tantalum -
			149 <b>W</b> tungsten -
			150 <b>Re</b> rhenium -
			151 <b>Os</b> osmium -
			152 <b>Ir</b> iridium -
			153 <b>Pt</b> platinum -
			154 <b>Au</b> gold -
			155 <b>Hg</b> mercury -
			156 <b>Tl</b> thallium -
			157 <b>Pb</b> lead -
			158 <b>Bi</b> bismuth -
			159 <b>Po</b> polonium -
			160 <b>At</b> astatine -
			161 <b>Rn</b> radon -
			162 <b>Fr</b> francium -
			163 <b>Ra</b> radium -
			164 <b>Ac</b> actinium -
			165 <b>Th</b> thorium -
			166 <b>Pa</b> protactinium -
			167 <b>U</b> uranium -
			168 <b>Np</b> neptunium -
			169 <b>Pu</b> plutonium -
			170 <b>Am</b> americium -
			171 <b>Cm</b> curium -
			172 <b>Bk</b> berkelium -
			173 <b>Cf</b> californium -
			174 <b>Es</b> einsteinium -
			175 <b>Fm</b> fermium -
			176 <b>Mn</b> manganese -
			177 <b>Fe</b> iron -
			178 <b>Co</b> cobalt -
			179 <b>Ni</b> nickel -
			180 <b>Cu</b> copper -
			181 <b>Zn</b> zinc -
			182 <b>Ga</b> gallium -
			183 <b>Ge</b> germanium -
			184 <b>As</b> arsenic -
			185 <b>Se</b> selenium -
			186 <b>Br</b> bromine -
			187 <b>Kr</b> krypton -
			188 <b>Rb</b> rubidium -
			189 <b>Sr</b> strontium -
			190 <b>Y</b> yttrium -
			191 <b>Zr</b> zirconium -
			192 <b>Nb</b> niobium -
			193 <b>Mo</b> molybdenum -
			194 <b>Tc</b> technetium -
			195 <b>Ru</b> ruthenium -
			196 <b>Rh</b> rhodium -
			197 <b>Pd</b> palladium -
			198 <b>Ag</b> silver -
			199 <b>Cd</b> cadmium -
			200 <b>In</b> indium -
			201 <b>Sn</b> tin -
			202 <b>Sb</b> antimony -
			203 <b>Te</b> tellurium -
			204 <b>I</b> iodine -
			205 <b>Xe</b> xenon -
			206 <b>Ba</b> barium -
			207 <b>La</b> lanthanum -
			208 <b>Ce</b> cerium -
			209 <b>Pr</b> praseodymium -
			210 <b>Nd</b> neodymium -
			211 <b>Pm</b> promethium -
			212 <b>Sm</b> samarium -
			213 <b>Eu</b> europium -
			214 <b>Gd</b> gadolinium -
			215 <b>Tb</b> terbium -
			216 <b>Dy</b> dysprosium -
			217 <b>Ho</b> holmium -
			218 <b>Er</b> erbium -
			219 <b>Tm</b> thulium -
			220 <b>Yb</b> ytterbium -
			221 <b>Lu</b> lutetium -
			222 <b>Hf</b> hafnium -
			223 <b>Ta</b> tantalum -
			224 <b>W</b> tungsten -
			225 <b>Re</b> rhenium -
			226 <b>Os</b> osmium -
			227 <b>Ir</b> iridium -
			228 <b>Pt</b> platinum -
			229 <b>Au</b> gold -
			230 <b>Hg</b> mercury -
			231 <b>Tl</b> thallium -
			232 <b>Pb</b> lead -
			233 <b>Bi</b> bismuth -
			234 <b>Po</b> polonium -
			235 <b>At</b> astatine -
			236 <b>Rn</b> radon -
			237 <b>Fr</b> francium -
			238 <b>Ra</b> radium -
			239 <b>Ac</b> actinium -
			240 <b>Th</b> thorium -
			241 <b>Pa</b> protactinium -
			242 <b>U</b> uranium -
			243 <b>Np</b> neptunium -
			244 <b>Pu</b> plutonium -
			245 <b>Am</b> americium -
			246 <b>Cm</b> curium -
			247 <b>Bk</b> berkelium -
			248 <b>Cf</b> californium -
			249 <b>Es</b> einsteinium -
			250 <b>Fm</b> fermium -
			251 <b>Mn</b> manganese -

## Mark Scheme for 2017 Chemistry Preliminary Examination Paper 1

Qn	Answer	LO	Type A/B
1	C	Methods of purification and analysis 1.2(a)	A
2	B	Methods of purification and analysis 1.2(b)	B
3	B	Identification of ions and gases 1.3(a), (b)	A
4	B	Identification of ions and gases 1.3(c), Kinetic particle theory 2.1(d)	B
5	A	Atomic structure 2.2(d), (f)	B
6	B	Structure and properties of materials 2.3(a)	A
7	C	Ionic bonding 2.4; Covalent Bonding 2.5	A
8	D	Covalent bonding 2.5(d)	B
9	B	Formulae, Stoichiometry and the Mole Concept 3(j), (l)	B
10	C	Formulae, Stoichiometry and the Mole Concept 3(i)	A
11	A	Formulae, Stoichiometry and the Mole Concept 3(h)	B
12	D	Electrolysis 4(f)	B
13	B	Electrolysis 4(j)	B
14	B	Energy from Chemicals 5(a), (b); Speed of reaction 6.1(c)	A
15	B	Energy from Chemicals 5(e)	A
16	D	Speed of reaction 6.1(a)	B
17	D	Experimental design 1.1(b)	B
18	C	Redox 6.2(c)	A
19	B	Acids and bases 7.1(a), (b)	A
20	D	Acids and bases 7.1(d), (h)	B
21	A	Ammonia 7.3(d)	A
22	C	Formulae, Stoichiometry and the Mole Concept 3(f), (j)	B
23	D	Acids and bases 7.1(g), (h); Air 10(d)(ii)	A
24	A	Group properties 8.2(a)	B
25	D	Group properties 8.2(b)	B
26	B	Acids and bases 7.1(i)	A
27	D	Transition elements 8.3(a)	A
28	C	Group properties 8.2(c)	A
29	B	Metals 9.2(a)(ii)	B
30	B	Iron 9.5(a)	A
31	C	Air 10(a)	A
32	C	Fuels & Crude Oil 11.1(b); Alkanes 11.2(a)	B
33	C	Alkenes 11.3(e), (f), (g)	B
34	D	Alkanes 11.2(d)	B
35	D	Alkenes 11.3(e)	B
36	C	Carboxylic acids 11.5(c)	A
37	D	Alkenes 11.3(e), Alcohols 11.4(c), Carboxylic acids 11.5(e)	B
38	C	Carboxylic acids 11.5(e)	B
39	C	Macromolecules 11.6(e)	A
40	A	Macromolecules 11.6(b), (d); Energy from Chemicals 5(c), (d)	B

Overview for Paper 1 & Paper 2

Topic	Paper 1		Paper 2		Overall
	Type A	Type B	Type A	Type B	Total marks
Experimental Chemistry	2	2	0	2	6
The Particulate Nature of Matter	2	3	2	2	9
Formulae, Stoichiometry and the Mole Concept	1	3	0	3	7
Electrolysis	0	2	7	0	9
Energy from Chemicals	2	0	5	0	7
Chemical Reactions	1	1	4	11	17
Acids, Bases and Salts	4	1	12	0	17
The Periodic Table	2	2	7	1	12
Metals	1	1	4	10	16
Air	1	0	1	0	2
Organic Chemistry	2	7	2	8	19
Data-based Questions	-	-	0	9	9
<b>Total</b>	<b>18</b>	<b>22</b>	<b>44</b>	<b>46</b>	<b>130</b>

% type A =  $(18 + 44) / 130 = 47.7\%$  (recommended 45%)

% type B =  $(22 + 46) / 130 = 52.3\%$  (recommended 55%)

Page 1	Mark Scheme	Syllabus	Paper
	CHIJ St. Theresa's Convent Preliminary Examination 2017	5073	2

Qn.	Part	Answer					LO	Type A/ B	Marks
		trend	only true down a group	only true across a period	true for both	not true for both			
	(a)	The mass number increases.			✓		Periodic Table 8.1	A	[2]
		The atomic radius increases.	✓						
		The melting point increases.				✓			
		There is a change in the character of the oxides from basic to amphoteric to acidic.		✓					
A1	(b)	(i) Reactivity increases down Group I and decreases down Group VII [1] For Group I: easier to remove valence electrons as they are further away from the nucleus/there are more electron shells [1] For Group VII: more difficult to accept/attract one electron as incoming electron is further away from the nucleus/there are more electron shells [1]  (ii) Group I: H atom has one valence electron / able to form singly positively charged ion ( $H^+$ ) [1] Group VII: H atom able to gain one electron to form a singly negatively charged ion ( $H^-$ ) / forms diatomic molecules ( $H_2$ ) [1]					Group Properties 8.2(a), (b)	A	[5]
	(c)	(i) The two ions are of the same charge and repel, hence they are not able to collide with each other (frequently) [1]  (ii) It is not (chemically) used up in the reaction / It is regenerated during the reaction [1]  (iii) It exhibits variable oxidation states. [1]					Speed of Reaction 6.1(b)  Transition Elements 8.3(a)	B	[3]
A2	(a)	(i) test tube A – rusting takes place due to presence of oxygen (air) and water [1] test tube B – rusting does not take place due to absence of water (absorbed by calcium chloride) [1] test tube C – rusting does not take place due to absence of oxygen (air) in boiled water [1]  (ii) indicator remains yellow [1] Zinc is more reactive than iron [1] and corrodes / reacts with oxygen (air) and water instead of iron [1]					Iron 9.5(d), (e)	B	[6]

Page 2	Mark Scheme	Syllabus	Paper
	CHIJ St. Theresa's Convent Preliminary Examination 2017	5073	2

	(b)	(i) steel / stainless steel [1] mixture of iron with one or more other elements (carbon / carbon and chromium) [1]  (ii) for steel: harder/stronger [1] than (pure) iron as the presence of atoms of different sizes make it more difficult for the layers of atoms to slide over one another [1]  for stainless steel: more resistant to corrosion [1] than (pure) iron [1] due to the presence of more reactive metals (e.g. chromium) that react with oxygen and water instead of iron to form a protective layer [1]	Properties of Metals 9.1(b), (d)	A	[4]																				
A3	(a)	oxygen [1]	Data-based questions	B	[1]																				
	(b)	Silicon dioxide / silica / SiO <sub>2</sub>		B	[1]																				
	(c)	The more reactive the metal is, the later the year of discovery. [1]	Metals 9.2(a), 9.3(a)	B	[1]																				
	(d)	Both copper and tin are scarce (less than 1%) so the cost of production is higher.	Data-based questions	B	[1]																				
	(e)	Aluminium and sodium [1] Isolation of metals by electrolysis was only possible after 1800 when the voltaic cell was invented/ the two metals are too high in the reactivity series to be isolated by reduction with carbon or hydrogen. [1]	Metals 9.2(a), 9.3(a)	B	[2]																				
	(f)	Aluminium requires a higher temperature to be melted / aluminium ores have a higher lattice energy due to the higher ionic charge, hence it is harder to be isolated.	Periodic Table, Metals 8, 9	B	[1]																				
A4	(a)	<table border="1"> <thead> <tr> <th>name of salt</th> <th>formula of salt</th> <th>name of acid used to make salt</th> <th>name of other compound used to make salt</th> <th>method of preparation (i), (ii) or (iii)</th> </tr> </thead> <tbody> <tr> <td>potassium nitrate</td> <td>KNO<sub>3</sub></td> <td>nitric acid</td> <td>potassium hydroxide / potassium carbonate</td> <td>(i)</td> </tr> <tr> <td>calcium phosphate</td> <td>Ca<sub>3</sub>(PO<sub>4</sub>)<sub>2</sub></td> <td>phosphoric acid</td> <td>calcium hydroxide / nitrate / chloride</td> <td>(iii)</td> </tr> <tr> <td>ammonium chloride</td> <td>NH<sub>4</sub>Cl</td> <td>hydrochloric acid</td> <td>aqueous ammonia / ammonium carbonate</td> <td>(i)</td> </tr> </tbody> </table> <p>1 mark for any 2 correct answers (max. 6)</p>	name of salt	formula of salt	name of acid used to make salt	name of other compound used to make salt	method of preparation (i), (ii) or (iii)	potassium nitrate	KNO <sub>3</sub>	nitric acid	potassium hydroxide / potassium carbonate	(i)	calcium phosphate	Ca <sub>3</sub> (PO <sub>4</sub> ) <sub>2</sub>	phosphoric acid	calcium hydroxide / nitrate / chloride	(iii)	ammonium chloride	NH <sub>4</sub> Cl	hydrochloric acid	aqueous ammonia / ammonium carbonate	(i)	Acids & Bases 7.1(d), (e), (h)  Salts 7.2(c)	A	[6]
	name of salt	formula of salt	name of acid used to make salt	name of other compound used to make salt	method of preparation (i), (ii) or (iii)																				
potassium nitrate	KNO <sub>3</sub>	nitric acid	potassium hydroxide / potassium carbonate	(i)																					
calcium phosphate	Ca <sub>3</sub> (PO <sub>4</sub> ) <sub>2</sub>	phosphoric acid	calcium hydroxide / nitrate / chloride	(iii)																					
ammonium chloride	NH <sub>4</sub> Cl	hydrochloric acid	aqueous ammonia / ammonium carbonate	(i)																					
(b)	<p>Titrate nitric acid (in burette) with potassium hydroxide / potassium carbonate (in pipette) using a suitable indicator (e.g. methyl orange). [1]</p> <p>Repeat titration using the same volume of nitric acid obtained earlier but without adding the indicator. [1]</p> <p>Heat the salt solution obtained to obtain a saturated solution (using evaporating dish). Leave the solution to cool for crystallisation to take place. [1]</p> <p>Filter the solution, and collect the crystals from the filter paper onto a paper towel, and allow to dry. [1]</p>	Salts 7.2(a), (c)	A	[4]																					

Page 3	Mark Scheme	Syllabus	Paper
	CHIJ St. Theresa's Convent Preliminary Examination 2017	5073	2

	(c)	<p>High m.p./b.p / hard [1] due to giant ionic lattice structure with strong electrostatic forces of attraction between oppositely charged <math>K^+</math> and <math>NO_3^-</math> ions that require a lot of energy to break/overcome [1] OR Good conductor of electricity in molten or aqueous state [1] due to presence of mobile <math>K^+</math> and <math>NO_3^-</math> ions that can move to conduct electricity when a potential difference is applied [1] OR Brittle [1] ions of the same charge are brought close together and repel each other when a stress/force is applied to the ionic lattice [1] OR Soluble in water [1] <math>K^+</math> and <math>NO_3^-</math> ions are able to form strong ion-solvent interactions with water that releases sufficient energy to cause the detachment of ions from the giant ionic lattice</p>	<p>Structure and properties of materials 2.3(d)</p> <p>Ionic Bonding 2.4(e)</p>	A	[2]								
	(d)	<table border="1"> <thead> <tr> <th>name of salt</th> <th>N : P : K ratio</th> </tr> </thead> <tbody> <tr> <td>potassium nitrate</td> <td>14 : 0 : 39</td> </tr> <tr> <td>calcium phosphate</td> <td>0 : 31 : 0 or 0 : 62 : 0</td> </tr> <tr> <td>ammonium chloride</td> <td>14 : 0 : 0</td> </tr> </tbody> </table> <p>1 mark for 2 correct answers 2 marks for 3 correct answers</p>	name of salt	N : P : K ratio	potassium nitrate	14 : 0 : 39	calcium phosphate	0 : 31 : 0 or 0 : 62 : 0	ammonium chloride	14 : 0 : 0	Data-based questions	B	[2]
name of salt	N : P : K ratio												
potassium nitrate	14 : 0 : 39												
calcium phosphate	0 : 31 : 0 or 0 : 62 : 0												
ammonium chloride	14 : 0 : 0												
A5	(a)	<p>(i) general formula: <math>C_nH_{2n}O</math> [1] functional group: <math>\begin{array}{c} O \\    \\ -C- \end{array}</math> [1] (ii) accept 101 – 104 °C [1] (iii) indicates position of C=O functional group (on the main hydrocarbon chain / backbone) [1] (iv) 2-propanone and propanal are isomers [1] They have the same molecular formula (of <math>C_3H_6O</math>) but different structural formula [1]</p>	Alkanes 11.2(a), (d)	B	[4]								
				A	[2]								

Page 4	Mark Scheme	Syllabus	Paper
	CHIJ St. Theresa's Convent Preliminary Examination 2017	5073	2

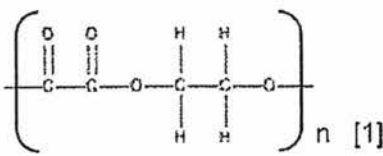
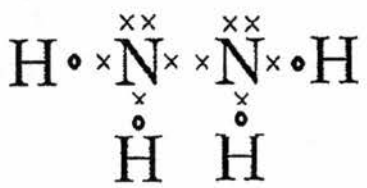
	(b)	(i) potassium manganate (VII) or potassium permanganate / $\text{KMnO}_4$ [1] colour change from purple to colourless [1] OR potassium dichromate (VI) / $\text{K}_2\text{Cr}_2\text{O}_7$ [1] colour change from orange to green [1]  (ii) $\text{C}_3\text{H}_7\text{OH} + [\text{O}] \rightarrow \text{C}_3\text{H}_6\text{O} + \text{H}_2\text{O}$ [1] All bonds must be shown.	Redox 6.2 (d)	A  B	[2]  [1]
B6	(a)	Comparing experiments 1 and 3, when the concentration of $\text{CH}_3\text{Br}$ is doubled, the rate of reaction is also doubled, hence the rate of reaction is directly proportional to $[\text{CH}_3\text{Br}]$ . OR Comparing experiments 1 and 4, when the concentration of $\text{CH}_3\text{Br}$ is tripled, the rate of reaction is also tripled, hence the rate of reaction is directly proportional to $[\text{CH}_3\text{Br}]$ . Order of reaction w.r.t $\text{CH}_3\text{Br} = 1$ [1] <i>reject order of reaction without logical reasoning.</i>	Speed of Reaction 6.1(f)	B	[1]
	(b)	Comparing experiments 2 and 3, when the concentration of $\text{NaOH}$ is doubled, the rate of reaction is also doubled, hence the rate of reaction is directly proportional to $[\text{NaOH}]$ . Order of reaction w.r.t $\text{NaOH} = 1$ [1] <i>reject order of reaction without logical reasoning.</i>	Speed of Reaction 6.1(f)	B	[1]
	(c)	Overall order = $1 + 1 = 2$ [1]	Data-based questions	B	[1]
	(d)	Rate = $k [\text{CH}_3\text{Br}][\text{NaOH}]$ [1]	Data-based questions	B	[1]
	(e)	$k = 0.05 \text{ mol}^{-1}\text{dm}^3\text{s}^{-1}$ 1 mark for both correct value and unit	Data-based questions	B	[1]
	(f)	Add a few drops of <u>acidified</u> aqueous silver nitrate [1] to the test solution. White precipitate formed [1]	Identification of ions and gases 1.3(b)	B	[2]
	(g)	W: dibromoethane / $\text{Br}(\text{CH}_2)_2\text{Br}$ [1] X: 1,2-ethane-diol / $\text{OH}(\text{CH}_2)_2\text{OH}$ [1] Y: ethanedioic acid / $(\text{COOH})_2$ [1] Z: 	Alcohols 11.4(c)  Macromolecules 11.6(d)	B	[4]
B7	(a)	 correct number of electrons for each atom [1] correct number of electrons shared for each bond [1]	Covalent Bonding 2.5(c)	B	[2]

Page 5	Mark Scheme	Syllabus	Paper
	CHIJ St. Theresa's Convent Preliminary Examination 2017	5073	2

	(b)	(i) Amount of energy required = 163 + 4(390) + 2(158) = 2036 kJ [1] (ii) Amount of energy released = 945 + 4(565) = 3205 kJ [1] (iii) $\Delta H$ for Reaction II = 2039 – 3205 = –1169 kJ [1]	Energy from Chemicals 5(c), (d)	A	[3]																		
	(c)	Fluorine, because the reaction is more exothermic / more energy is released. [1] OR Oxygen, because no pollutants are produced/released [1]	Data-based Questions	B	[1]																		
	(d)	Correct shape of graph and labelled reactants and products [1] Correct labelled activation energy for the forward reaction + Correct labelled enthalpy change [1] Do not allow double headed arrow head / arrow in wrong direction Note – arrows do not have to start exactly at reactant level and finish exactly at product or maximum of curve Maximum of one mark for an error carried forward for a reaction that is endothermic i.e. enthalpy change mark and activation energy	Energy from Chemicals 5(b)	A	[2]																		
	(e)	Oxides of nitrogen dissolve in rainwater forming acid rain that corrodes limestone structures and building and causes harm to aquatic plants/animals [1]	Air 10(e)(ii)	A	[1]																		
EITHER B8	(a)	nitrogen – fractional distillation of liquid air [1] hydrogen – cracking of petroleum / crude oil [1]	Ammonia 7.3(a)	A	[2]																		
	(b)	Nitrogen as the oxidation state <u>decreases</u> from 0 in $N_2$ to –3 in $NH_3$ . [1]	Redox	B	[1]																		
	(c)	(i) Higher temperature ⇒ increase in kinetic energy & speed of particles [1] ⇒ increase in frequency of effective collisions [1] ⇒ increase in rate of reaction (ii) 350 °C and 400 atmospheres [1] (iii) no effect on yield of ammonia [1] increases the speed of both the forward and reverse reactions to the same extent [1] (iv) to increase yield of ammonia / reduce cost/ reduce waste / save materials or resources [1] (v) reversible reaction [1]	Speed of Reaction 6.1(a), 6.1(b)  Ammonia 7.3(b), (c)	A	[2]																		
				B	[1]																		
				B	[2]																		
B				[1]																			
B	[1]																						
OR B8	(a)	<table border="1"> <thead> <tr> <th>solution</th> <th colspan="2">name of products of electrolysis</th> <th>ionic equation for reaction at each electrode</th> </tr> </thead> <tbody> <tr> <td rowspan="2">dilute aqueous lead(II) nitrate</td> <td>at negative electrode</td> <td>hydrogen (gas)</td> <td><math>2H^+ + 2e^- \rightarrow H_2(g)</math></td> </tr> <tr> <td>at positive electrode</td> <td>oxygen (gas) and water</td> <td><math>4OH^-(aq) \rightarrow 2H_2O(aq) + O_2(g) + 4e^-</math></td> </tr> <tr> <td rowspan="2">concentrated aqueous copper(II) chloride</td> <td>at negative electrode</td> <td>copper (solid)</td> <td><math>Cu^{2+}(aq) + 2e^- \rightarrow Cu(s)</math></td> </tr> <tr> <td>at positive electrode</td> <td>chlorine (gas)</td> <td><math>2Cl^-(aq) \rightarrow Cl_2(g) + 2e^-</math></td> </tr> </tbody> </table>	solution	name of products of electrolysis		ionic equation for reaction at each electrode	dilute aqueous lead(II) nitrate	at negative electrode	hydrogen (gas)	$2H^+ + 2e^- \rightarrow H_2(g)$	at positive electrode	oxygen (gas) and water	$4OH^-(aq) \rightarrow 2H_2O(aq) + O_2(g) + 4e^-$	concentrated aqueous copper(II) chloride	at negative electrode	copper (solid)	$Cu^{2+}(aq) + 2e^- \rightarrow Cu(s)$	at positive electrode	chlorine (gas)	$2Cl^-(aq) \rightarrow Cl_2(g) + 2e^-$	Electrolysis 4(e), (f), (g)	A	[4]
		solution	name of products of electrolysis		ionic equation for reaction at each electrode																		
		dilute aqueous lead(II) nitrate	at negative electrode	hydrogen (gas)	$2H^+ + 2e^- \rightarrow H_2(g)$																		
			at positive electrode	oxygen (gas) and water	$4OH^-(aq) \rightarrow 2H_2O(aq) + O_2(g) + 4e^-$																		
concentrated aqueous copper(II) chloride	at negative electrode	copper (solid)	$Cu^{2+}(aq) + 2e^- \rightarrow Cu(s)$																				
	at positive electrode	chlorine (gas)	$2Cl^-(aq) \rightarrow Cl_2(g) + 2e^-$																				
1 mark for each correct row																							

Page 6	Mark Scheme	Syllabus	Paper
	CHIJ St. Theresa's Convent Preliminary Examination 2017	5073	2

	solution	observations				
(b)	dilute aqueous lead(II) nitrate	at negative electrode	Effervescence / bubbles	Electrolysis 4(e), (f), (g)	A	[3]
		at positive electrode	Effervescence / bubbles			
		in electrolyte	No change observed			
	concentrated aqueous copper(II) chloride	at negative electrode	Pink / reddish brown deposit			
		at positive electrode	Effervescence / bubbles			
		in electrolyte	Blue colour fades/ becomes lighter lighter			
1 mark for every 2 correct answers						
(c)	$n[\text{Pb}(\text{NO}_3)_2] = 0.5 \times (20/1000) = 0.01 \text{ mol}$ $n[\text{CuCl}_2] = 0.8 \times (15/1000) = 0.012 \text{ mol}$ [1]		Formulae, Stoichiometry and the Mole Concept 3(g), (k)	B	[3]	
Mole ratio of $\text{Pb}(\text{NO}_3)_2 : \text{CuCl}_2 = 1 : 1$						
$n(\text{PbCl}_2) = 0.01 \text{ mol}$ [1]						
$m(\text{PbCl}_2) = 0.01 \times (207 + 71) = 2.78 \text{ g}$ [1]						