

Visit

FREETESTPAPER.com

for more papers



Website: [freetestpaper.com](http://www.freetestpaper.com)



[Facebook.com/freetestpaper](https://www.facebook.com/freetestpaper)



[Twitter.com/freetestpaper](https://www.twitter.com/freetestpaper)

NAME: _____ () CLASS: _____



ST JOSEPH'S INSTITUTION

PRELIMINARY EXAMINATION 2017
SECONDARY 4 ('O' Level Programme)

CHEMISTRY

5073 / 01

Paper 1 Multiple Choice

23 August 2017

1 hour

Additional materials: Multiple Choice Answer Sheet

1045 – 1145 h

READ THESE INSTRUCTIONS FIRST

Write in soft pencil.

Do not use staples, paper clips, highlighters, glue or correction fluid.

Write your name, class and index number on the Answer Sheet in the spaces provided.

There are **forty** questions on this paper. Answer **all** questions. For each question, there are four possible answers **A, B, C and D**.

Choose the **one** you consider correct and record your choice in **soft pencil** on the separate Answer Sheet.

Read the instructions on the Answer Sheet very carefully.

Each correct answer will score one mark. A mark will not be deducted for a wrong answer.

Any rough working should be done in the question paper.

The use of an approved scientific calculator is expected, where appropriate.

A copy of the Periodic Table is printed on page 2.

This question paper consists of **24 printed pages** including the Cover Sheet.

[Turn over]

DATA SHEET
The Periodic Table of the Elements

I		II		Group										III	IV	V	VI	VII	0																																																																																																																																																																																																																																																																																																																																																																																																																																																																																																																																																																																																																																																																																																																																																																																																																																																																																																																																																																																																																				
1	2	3	4	5	6	7	8	9	10	11	12	13	14	15	16	17	18	19	20	21	22	23	24	25	26	27	28	29	30	31	32	33	34	35	36	37	38	39	40	41	42	43	44	45	46	47	48	49	50	51	52	53	54	55	56	57	58	59	60	61	62	63	64	65	66	67	68	69	70	71	72	73	74	75	76	77	78	79	80	81	82	83	84	85	86	87	88	89	90	91	92	93	94	95	96	97	98	99	100	101	102	103	104	105	106	107	108	109	110	111	112	113	114	115	116	117	118	119	120	121	122	123	124	125	126	127	128	129	130	131	132	133	134	135	136	137	138	139	140	141	142	143	144	145	146	147	148	149	150	151	152	153	154	155	156	157	158	159	160	161	162	163	164	165	166	167	168	169	170	171	172	173	174	175	176	177	178	179	180	181	182	183	184	185	186	187	188	189	190	191	192	193	194	195	196	197	198	199	200	201	202	203	204	205	206	207	208	209	210	211	212	213	214	215	216	217	218	219	220	221	222	223	224	225	226	227	228	229	230	231	232	233	234	235	236	237	238	239	240	241	242	243	244	245	246	247	248	249	250	251	252	253	254	255	256	257	258	259	260	261	262	263	264	265	266	267	268	269	270	271	272	273	274	275	276	277	278	279	280	281	282	283	284	285	286	287	288	289	290	291	292	293	294	295	296	297	298	299	300	301	302	303	304	305	306	307	308	309	310	311	312	313	314	315	316	317	318	319	320	321	322	323	324	325	326	327	328	329	330	331	332	333	334	335	336	337	338	339	340	341	342	343	344	345	346	347	348	349	350	351	352	353	354	355	356	357	358	359	360	361	362	363	364	365	366	367	368	369	370	371	372	373	374	375	376	377	378	379	380	381	382	383	384	385	386	387	388	389	390	391	392	393	394	395	396	397	398	399	400	401	402	403	404	405	406	407	408	409	410	411	412	413	414	415	416	417	418	419	420	421	422	423	424	425	426	427	428	429	430	431	432	433	434	435	436	437	438	439	440	441	442	443	444	445	446	447	448	449	450	451	452	453	454	455	456	457	458	459	460	461	462	463	464	465	466	467	468	469	470	471	472	473	474	475	476	477	478	479	480	481	482	483	484	485	486	487	488	489	490	491	492	493	494	495	496	497	498	499	500	501	502	503	504	505	506	507	508	509	510	511	512	513	514	515	516	517	518	519	520	521	522	523	524	525	526	527	528	529	530	531	532	533	534	535	536	537	538	539	540	541	542	543	544	545	546	547	548	549	550	551	552	553	554	555	556	557	558	559	560	561	562	563	564	565	566	567	568	569	570	571	572	573	574	575	576	577	578	579	580	581	582	583	584	585	586	587	588	589	590	591	592	593	594	595	596	597	598	599	600	601	602	603	604	605	606	607	608	609	610	611	612	613	614	615	616	617	618	619	620	621	622	623	624	625	626	627	628	629	630	631	632	633	634	635	636	637	638	639	640	641	642	643	644	645	646	647	648	649	650	651	652	653	654	655	656	657	658	659	660	661	662	663	664	665	666	667	668	669	670	671	672	673	674	675	676	677	678	679	680	681	682	683	684	685	686	687	688	689	690	691	692	693	694	695	696	697	698	699	700	701	702	703	704	705	706	707	708	709	710	711	712	713	714	715	716	717	718	719	720	721	722	723	724	725	726	727	728	729	730	731	732	733	734	735	736	737	738	739	740	741	742	743	744	745	746	747	748	749	750	751	752	753	754	755	756	757	758	759	760	761	762	763	764	765	766	767	768	769	770	771	772	773	774	775	776	777	778	779	780	781	782	783	784	785	786	787	788	789	790	791	792	793	794	795	796	797	798	799	800	801	802	803	804	805	806	807	808	809	810	811	812	813	814	815	816	817	818	819	820	821	822	823	824	825	826	827	828	829	830	831	832	833	834	835	836	837	838	839	840	841	842	843	844	845	846	847	848	849	850	851	852	853	854	855	856	857	858	859	860	861	862	863	864	865	866	867	868	869	870	871	872	873	874	875	876	877	878	879	880	881	882	883	884	885	886	887	888	889	890	891	892	893	894	895	896	897	898	899	900	901	902	903	904	905	906	907	908	909	910	911	912	913	914	915	916	917	918	919	920	921	922	923	924	925	926	927	928	929	930	931	932	933	934	935	936	937	938	939	940	941	942	943	944	945	946	947	948	949	950	951	952	953	954	955	956	957	958	959	960	961	962	963	964	965	966	967	968	969	970	971	972	973	974	975	976	977	978	979	980	981	982	983	984	985	986	987	988	989	990	991	992	993	994	995	996	997	998	999	1000

The volume of one mole of any gas is 24 dm³ at room temperature and pressure (r.t.p.).

*58-71 Lanthanoid series
190-103 Actinoid series

Key

a	X
b	X

 a = relative atomic mass
 X = atomic symbol
 b = proton (atomic) number

- 1 The apparatus shown in the diagram below was set up by Peter to measure the volume of carbon dioxide gas made when different masses of marble chips were added to 25 cm³ of dilute hydrochloric acid.

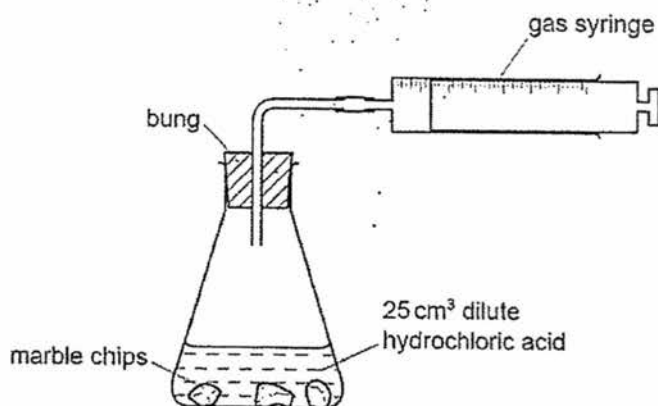

Which other apparatus did he use for his experiment?

- A Filter funnel and mass balance
 B Filter funnel and stopwatch
 C Measuring cylinder and mass balance
 D Measuring cylinder and stopwatch
- 2 The table gives data about four substances.
 In which substance are the particles closely packed and arranged randomly at room temperature?

Substance	Melting point / °C	Boiling point / °C
A	15	145
B	40	1407
C	-114	-30
D	-20	10

- 3 The nucleon number and number of electrons of an atom of X and an atom of Y are shown.

Atom	X	Y
Nucleon number	51	51
Number of electrons	23	27

Which statement about X and Y is incorrect?

- A An atom of X has fewer protons than an atom of Y.
 B An atom of Y has fewer neutrons than an atom of X.
 C X is above Y in the same group of the Periodic Table.
 D X is in the same period in the Periodic Table as Y.
- 4 Which of the following statements describes a particle with the following electronic structure?

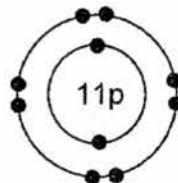

- A an anion with an oxidation state of -1
 B a cation with an oxidation state of $+1$
 C an atom in the second period
 D an inert gas atom

- 5 The dot-cross diagram (with only the outer electrons) of the compound formed between element X and Z is shown.

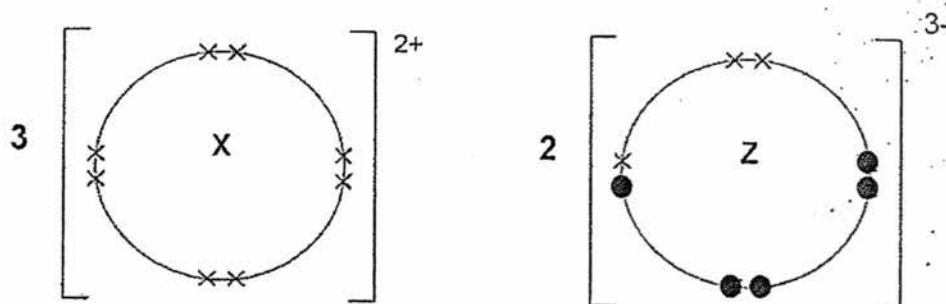

Which of the following is the correct set of formula of the chloride of X and Z?

- A XCl, Z_3Cl
- B XCl, ZCl_3
- C XCl_2, Z_3Cl
- D XCl_2, ZCl_3

- 6 The diagram shows the molecule propyl ethanoate.

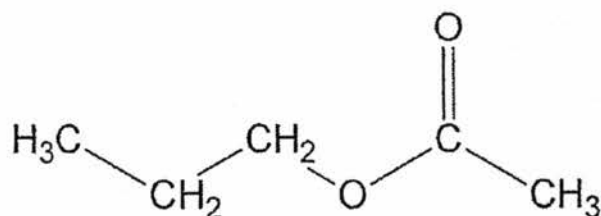

How many pairs of electrons are used in bonding in the molecule?

- A 1
 B 7
 C 14
 D 17
- 7 The table below shows the physical properties of substances P, Q, R and S.

Substance	Melting point /°C	Electrical Conductivity	
		in solid state	in molten state
P	High	Poor	Good
Q	High	Good	Good
R	High	Poor	Poor
S	Low	Poor	Poor

Using the information from the table, which statement is true about substances P, Q, R and S?

- A Substance R consists of weak bonds between the atoms.
 B Substance S exists in a simple molecular structure.
 C Substance P contains mobile electrons to conduct electricity when in molten state.
 D Substance Q consists of strong electrostatic attractions between oppositely charged particles.

- 8 Chlorine gas is a severe irritant to the eyes and respiratory system. The maximum safe toleration level of chlorine gas in air is 0.005 mg dm^{-3} .

How many molecules of chlorine gas are present in 1 dm^3 of air at the toleration level? (Note: $1 \text{ g} = 1000 \text{ mg}$)

- A $\frac{0.005}{6 \times 10^{23}} \times 71$
- B $\frac{0.005}{71} \times 6 \times 10^{23}$
- C $\frac{0.005}{1000} \times \frac{1}{71} \times 6 \times 10^{23}$
- D $\frac{0.005}{1000} \times 71 \times 6 \times 10^{23}$
- 9 Dinitrogen tetroxide, N_2O_4 is a poisonous gas. It can be disposed of safely by reaction with sodium hydroxide. In the experiment, the concentration of aqueous sodium hydroxide used is 1.5 mol/dm^3 .



Which of the following is the least volume of aqueous sodium hydroxide required to dispose of 300 cm^3 of N_2O_4 at room temperature and pressure?

- A 10 cm^3
- B 20 cm^3
- C 200 cm^3
- D 600 cm^3

- 10 Sulfuric acid and nitric acid are both strong acids.
Ethanoic acid is a weak acid.

20.00 cm³ solutions of 0.10 mol/dm³ concentration of each of these three acids were separately titrated with a 0.10 mol/dm³ solution of sodium hydroxide.

In order to react completely

- A all three acids would require the same volume of sodium hydroxide solution.
- B ethanoic acid and nitric acid would require the same volume of sodium hydroxide solution but sulfuric acid would require more.
- C nitric acid would require more sodium hydroxide solution than ethanoic acid but less than sulfuric acid.
- D sulfuric acid and nitric acid would require the same volume of sodium hydroxide solution but ethanoic acid would require less.
- 11 Solution X and solid Y are mixed in a beaker. After mixing, the final mass of the substances and the beaker is lesser than the initial mass.

What could solution X and solid Y be?

	solution X	solid Y
A	hydrochloric acid	iron(III) hydroxide
B	nitric acid	magnesium oxide
C	potassium hydroxide	ammonium carbonate
D	sulfuric acid	copper

- 12 The graph below shows the change in pH of a reaction solution during a titration of 0.10 mol/dm^3 sodium hydroxide solution with 0.10 mol/dm^3 ethanoic acid.

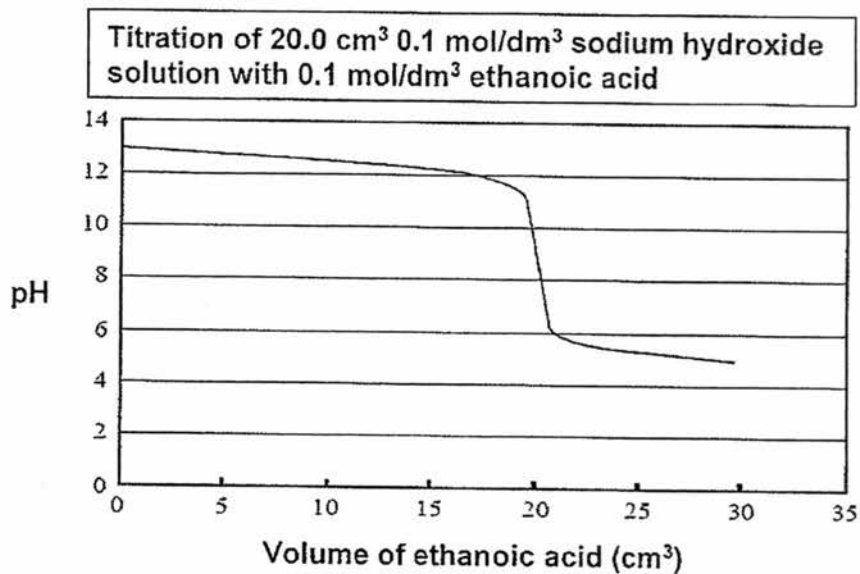

Below are the approximate pH changes for a few indicators.

Indicator	Approximate pH range for colour change
Methyl orange	3.2-4.4
Phenolphthalein	8.2-10
Litmus solution	5.5-8.2
Bromocresol green	3.8-5.4

Which indicator is the *most suitable* to identify the end point of this titration?

- A Bromocresol green
- B Litmus solution
- C Methyl orange
- D Phenolphthalein

- 13 An excess of sodium hydroxide is added to an aqueous solution of salt L and boiled. Ammonia gas is only given off after aluminium foil is added to the hot solution. What could be salt L?
- A Ammonium chloride
- B Ammonium nitrate
- C Sodium chloride
- D Sodium nitrate
- 14 Excess dilute sulfuric acid was added to a fixed volume of aqueous barium hydroxide.

Which graph best represents the variation in the total number of mobile ions present in the solution?

A

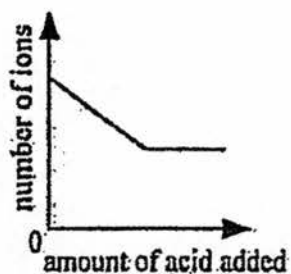

B

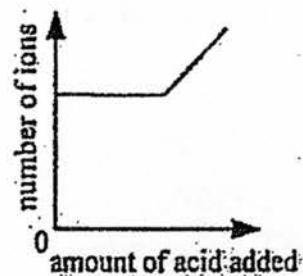

C

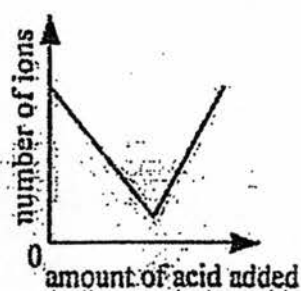

D

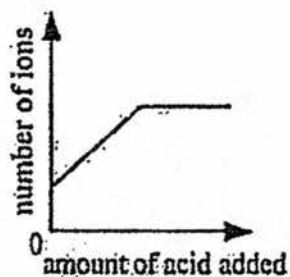

- 15 Elements Q, X, Y and Z are found in consecutive groups of the Periodic Table starting from group IV. They also belong to the same period. In which molecule are all the outer electrons of the atoms involved in bonding?
- A QH₄
- B XH₃
- C YH₂
- D ZH
- 16 X is a Group I element while Y is a transition element. Which of the following states the correct similarity and difference in their properties?

	Similarity	Difference
A	X and Y have high melting point.	Y has higher density than X.
B	X and Y have high melting point.	Y is harder than X.
C	X and Y conduct electricity.	X is soluble in water while Y is insoluble in water.
D	X and Y form coloured compounds.	X does not conduct electricity while Y conducts electricity.

- 17 Adrian carried out four experiments to arrange metals X, Y and Z in order of decreasing reactivity.

The table shows the results of his experiments:

Experiment	X	Y	Z
Does the metal react with dilute hydrochloric acid?	yes	no	yes
Is the oxide of the metal reduced by heating with carbon?	yes	yes	no

What is the order of reactivity of the metals?

	Most reactive	→	Least reactive
A	X		Y
B	Y		Z
C	Z		Y
D	Z		X

- 18 Joseph performed four experiments on rusting as shown below.

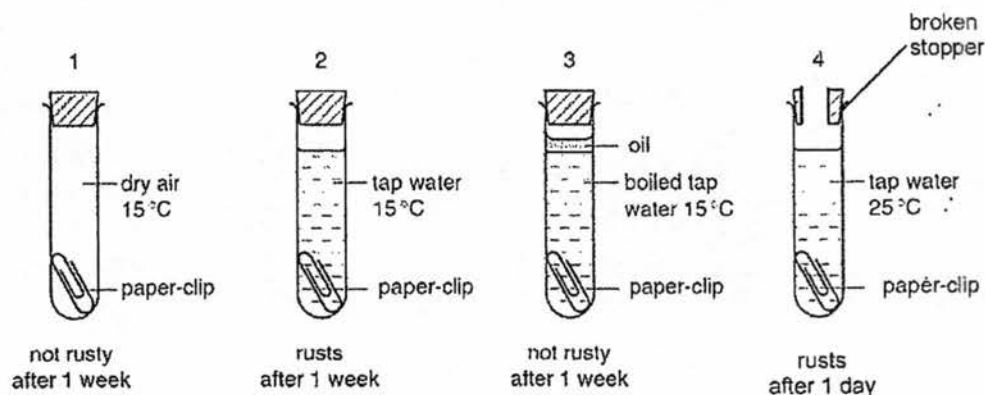

Which two of these experiments can Joseph use to show that air is needed for iron to rust?

- A 1 and 2
- B 1 and 3
- C 2 and 3
- D 2 and 4

19 Which of the following is a redox reaction?

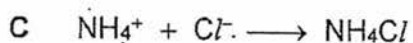
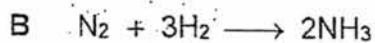
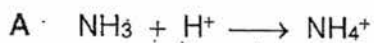

20 A piece of clean copper wire is suspended in a beaker of aqueous silver nitrate. Crystals of silver are deposited on the copper wire and the solution in the beaker gradually turns blue.

Which deduction is **not** correct?

A Copper is oxidised.

B Silver nitrate is reduced.

C The total number of negative ions in the solution is unchanged.

D The total number of positive ions in the solution is unchanged.

- 21 Aqueous potassium iodide and acidified potassium manganate (VII) were added to separate samples of hydrogen peroxide.

The observations are summarised in the table.

Reagent added to hydrogen peroxide	Observations
Aqueous potassium iodide	Aqueous potassium iodide turns from colourless to brown
Acidified potassium manganate (VII)	Acidified potassium manganate (VII) turns from purple to colourless.

Which of the following set of properties is correct for the above observations?

	Aqueous potassium iodide	Acidified potassium manganate(VII)
A	Oxidising agent	Reducing agent
B	Oxidising agent	Oxidising agent
C	Reducing agent	Oxidising agent
D	Reducing agent	Reducing agent

- 22 In the electrolysis of molten aluminium oxide, 4 moles of aluminium ions (Al^{3+}) were discharged at the cathode.

Which one of the following would be discharged by the same amount of electricity?

- A 4 moles copper(II) ions (Cu^{2+}) in the electrolysis of aqueous copper (II) sulfate
- B 6 moles of lead ions (Pb^{2+}) in the electrolysis of molten lead(II) bromide
- C 6 moles of silver ions (Ag^+) in the electrolysis of aqueous silver nitrate
- D 12 moles of zinc ions (Zn^{2+}) in the electrolysis of molten zinc sulfate

- 23 A current is passed through two electrolytic cells, R and T, for some time. The electrolyte in both cells is green nickel(II) sulfate solution of the same concentration. Cell R has two nickel electrodes, while Cell T has a nickel and a platinum electrode.

The results are summarised in the table below.

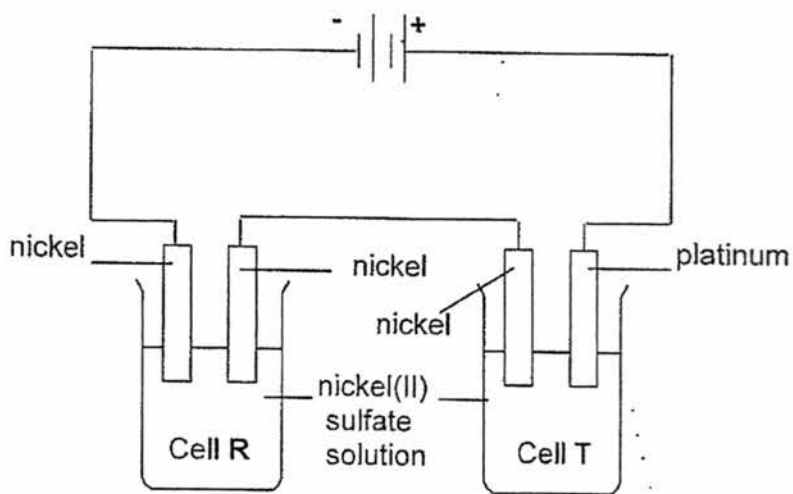

Cell	Cathode	Anode
R	4.0 g of nickel is deposited.	Nickel dissolves.
T	Nickel is deposited.	Oxygen evolved.

Which statement about the reactions above is **not** true?

- A The oxygen evolved at the anode of Cell T burns the platinum.
- B The cathode in Cell R increases in mass by 4.0 g.
- C The concentration of the nickel(II) sulfate solution in Cell R remains the same.
- D The green colour of the nickel(II) sulfate solution in Cell T fades slowly and eventually disappears.

- 24 Four metals tin, x, y and z were connected in pairs and the voltages were recorded.

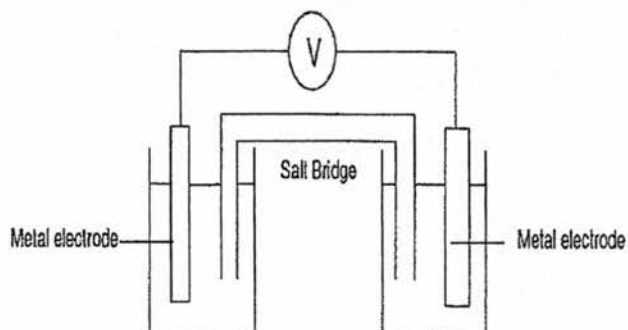

The results obtained are shown in the table below:

negative terminal	positive terminal	Voltage (V)
tin	y	+ 1.10
x	tin	+ 0.90
z	tin	+ 2.50

What is the order of reactivity of the four metals with the most reactive first?

- A x, tin, y, z
 B y, tin, x, z
 C z, tin, y, x
 D z, x, tin, y

- 25 The table below shows the differences in the composition of the mixtures of exhaust gases from two cars, one fitted with a catalytic converter and one without.

	% by volume of nitrogen monoxide	% by volume of carbon dioxide	% by volume of water vapour
Car without catalytic converter	67.60	12.00	11.00
Car with catalytic converter	23.60	32.25	41.10

Which statement does **not** explain the differences in the data above?

- A The percentage of nitrogen monoxide decreases as it is oxidised to form nitrogen in the catalytic converter.
 - B The percentage of nitrogen monoxide decreases as it is reduced to form nitrogen in the catalytic converter.
 - C The percentage of carbon dioxide increases as unburnt hydrocarbons undergo complete combustion in the catalytic converter.
 - D The percentage of water vapour increases as unburnt hydrocarbons undergo complete combustion in the catalytic converter.
- 26 To reduce atmospheric pollution, the following waste gases from a coal burning power station are passed through wet powdered calcium carbonate.

How many of the following waste gases will **not** be removed by the wet powdered calcium carbonate?

carbon monoxide	carbon dioxide
nitrogen monoxide	nitrogen dioxide
sulfur dioxide	phosphorus(V) oxide

- A 1
- B 2
- C 3
- D 4

27 The enthalpy of vaporization, (ΔH_{vap}) is the amount of energy absorbed to convert one mole of a liquid substance into a gas. The ΔH_{vap} for water is +40.7 kJ/mol at 100°C and 1 atm.

Which of the following statements is true?

- A The ΔH_{vap} for water is positive as energy is absorbed to break O-H bonds.
- B 226 kJ of heat is absorbed to convert 100g of water into steam at 100°C and 1 atm
- C Less than 226 kJ of heat is absorbed to convert 100g of water at 25°C into steam at 1 atm.
- D Energy is absorbed to transform water molecules vibrating in fixed positions into molecules moving randomly at high speeds.

28 Which of the following processes are exothermic in nature?

- I. Rusting of iron metal
- II. Neutralisation of butanoic acid with alkali
- III. Thermal decomposition of calcium carbonates
- IV. Breaking down of hydrogen chloride into its constituent atoms
- V. Combustion of sulfur to form an acidic gas

- A I, II and III
- B I, II and V
- C I, II, III, IV
- D All of the above

- 29 A piece of zinc foil dissolved completely in 20 cm^3 of a dilute sulfuric acid solution, and the volume of hydrogen evolved was noted at equal, short time intervals.

Another piece of zinc foil of the same surface area and mass was added to 40 cm^3 of the same solution of dilute sulfuric acid.

How will the initial rate of reaction and the total volume of hydrogen evolved in this second experiment compare to the first experiment?

- | | initial rate of reaction | total volume of hydrogen evolved |
|---|--------------------------|----------------------------------|
| A | no change | Increase |
| B | no change | no change |
| C | increase | no change |
| D | increase | increase |
- 30 When sodium thiosulfate reacts with dilute hydrochloric acid, a fine suspension of sulfur is formed.

An experiment was carried out at various temperatures and the time taken for the suspension to appear was recorded in the table below.

Temperature / °C	Time taken / s
30	97
35	52
40	42
50	24

Which one of the following conclusions about the experiment can be drawn from the above table?

- A The shorter the time taken, the higher the temperature rise of the reaction.
- B The longer the time taken, the lower the temperature rise of the reaction.
- C The higher the temperature, the lower the rate of formation of sulfur.
- D The higher the temperature, the higher the rate of formation of sulfur.

- 31 In the graph shown below, curve X represents the result of the reaction between 2.5g of magnesium ribbon and 50 cm³ of 1 mol/dm³ sulfuric acid at 50°C.

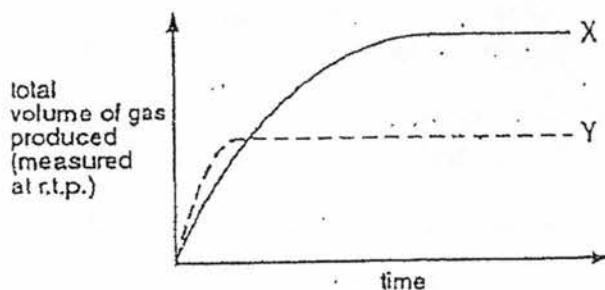

Which reaction could produce curve Y?

- A 2.5g of magnesium powder at 50°C
- B 2.5g of magnesium ribbon at 60°C
- C 12.5 cm³ of 2 mol/dm³ sulfuric acid at 60°C
- D 25 cm³ of 2 mol/dm³ sulfuric acid at 50°C
- 32 Which statement about speed of reaction is correct?
- A Increasing the concentration of a reactant increases the speed because there are more rapidly moving particles.
- B Increasing the size of particles of a solid increases the speed because there are more particles.
- C Increasing temperature increases the speed because it increases the number of particles.
- D Increasing temperature increases the speed because there are more collisions.

- 33 Why is it wasteful to add ammonium nitrate fertiliser to soil which has recently been treated with slaked lime?
- Ammonium nitrate can be easily decomposed.
 - Ammonium nitrate will react with slaked lime and ammonia is released into the air.
 - Slaked lime has made the soil too basic for ammonium nitrate to be useful.
 - The percentage by mass of nitrogen in ammonium nitrate is low.
- 34 Which of the following statements about alkanes and alkenes is true?
- Alkanes are unsaturated but alkenes are saturated.
 - Alkanes undergo substitution while alkenes undergo addition.
 - Alkanes and alkenes belong to the same homologous series.
 - Alkanes have a higher percentage composition of carbon than the corresponding alkene.
- 35 The structure of but-2-ene is as shown. But-2-ene undergoes an addition reaction with hydrobromic acid, HBr in a similar way that it reacts with bromine.

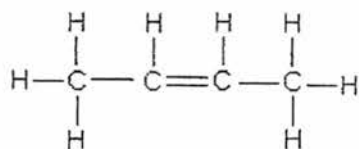

Which of the following statements is true about the reaction between but-2-ene and HBr?

- The product is a mixture of two structural isomers
- Both the reactants and products are unsaturated.
- The product has a higher boiling point than the reactant.
- The product can undergo addition reaction with hydrogen.

- 36 An open can of beer is left exposed to the air for several days and was found to acquire a sour taste. Which of the following statements best explains this phenomenon?
- A The fermentation of glucose takes place in the can of beer.
- B The oxidation of ethanol occurs to form ethanoic acid.
- C The decomposition of carbohydrates in the beer occurs to form ethanoic acid.
- D Carbon dioxide from the fermentation reacts with water to form carbonic acid.
- 37 The smell in citrus fruits is due to an organic compound, limonene, found in them. Which of the following statements apply to limonene?

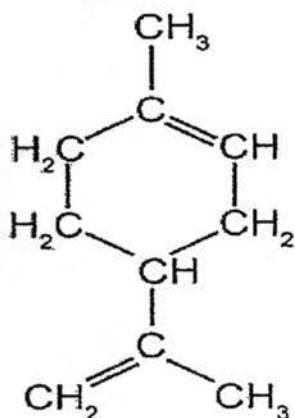

- I. Limonene undergoes addition polymerisation.
- II. Limonene decolourises brown bromine water.
- III. Limonene is saturated hydrocarbon.
- IV. Limonene reacts with excess hydrogen gas to form a saturated product.
- V. Limonene reacts with steam under suitable conditions to form an acid.
- A I, II, IV
- B II, IV, V
- C I, II, III, V
- D All of the above.

- 38 Ethane undergoes substitution reaction with bromine gas under certain conditions to form bromoethane.

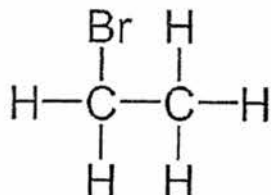

Which of the following statements about the above reaction is true?

- A The reaction should be carried out at room temperature in darkness.
 - B The side product of this reaction is hydrogen bromide, HBr.
 - C There are two possible isomers of bromoethane.
 - D A suitable solvent for the reactant mixture is water.
- 39 Which of the following physical property of the alcohols increases when the number of carbon atoms increases?
- A Boiling Point
 - B Fluidity
 - C Flammability
 - D Water solubility

- 40 The structure shown below is maleic acid. It can be used as a monomer to make polymers. Which of the following statements is true?

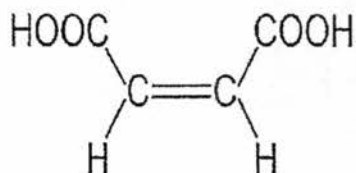

- A It can undergo addition polymerisation with $\text{HN}_2\text{CH}_2\text{CH}_2\text{NH}_2$.
- B It can undergo condensation polymerisation with $\text{HOCH}_2\text{CH}_2\text{OH}$.
- C When maleic acid undergoes addition polymerisation, it loses water molecules.
- D When maleic acid undergoes condensation polymerisation, polymaleic acid is formed.

NAME: _____ () CLASS: _____



ST JOSEPH'S INSTITUTION

PRELIMINARY EXAMINATION 2017
SECONDARY 4 ('O' Level Programme)

CHEMISTRY

5073 / 02

Paper 2

15 Aug 2017

Candidates answer on the Question Paper.

1 hour 45 minutes

Additional materials: NIL

1100 – 1245h

READ THESE INSTRUCTIONS FIRST

Write your name, index number and class on all the work you hand in.
Write in dark blue or black pen on both sides of the paper.

You may use a soft pencil for any diagrams, graphs or rough working.
Do not use staples, paper clips, highlighters, glue or correction fluid.

Section A

Answer **all** questions in the spaces provided.

Section B

Answer **all three** questions, the last question is in the form either / or.

Answer **all** questions in the spaces provided.

At the end of the examination, hand in
Sections A and B SEPARATELY.

The number of marks is given in brackets [] at the end of each question or part question.
Electronic calculators may be used in this paper.
A copy of the Periodic Table is found on page 2.

This question paper consists of 23 printed pages including the Cover Sheet.

[Turn over]

DATA SHEET
The Periodic Table of the Elements

		Group																																																																																																				
I	II	III	IV	V	VI	VII	0																																																																																															
7 Li Lithium 3	9 Be Beryllium 4	1 H Hydrogen 1	11 B Boron 5	12 C Carbon 6	14 N Nitrogen 7	16 O Oxygen 8	19 F Fluorine 9	20 Ne Neon 10	23 Va Vanadium 23	24 Cr Chromium 24	25 Mn Manganese 25	26 Fe Iron 26	27 Co Cobalt 27	28 Ni Nickel 28	29 Cu Copper 29	30 Zn Zinc 30	31 Ga Gallium 31	32 Ge Germanium 32	33 As Arsenic 33	34 Se Selenium 34	35 Br Bromine 35	36 Kr Krypton 36	39 K Potassium 19	40 Ca Calcium 20	41 Sc Scandium 21	42 Ti Titanium 22	43 V Vanadium 23	44 Cr Chromium 24	45 Mn Manganese 25	46 Fe Iron 26	47 Co Cobalt 27	48 Ni Nickel 28	49 Cu Copper 29	50 Zn Zinc 30	51 Ga Gallium 31	52 Ge Germanium 32	53 As Arsenic 33	54 Se Selenium 34	55 Br Bromine 35	56 Kr Krypton 36	57 La Lanthanum 57	58 Ce Cerium 58	59 Pr Praseodymium 59	60 Nd Neodymium 60	61 Pm Promethium 61	62 Sm Samarium 62	63 Eu Europium 63	64 Gd Gadolinium 64	65 Tb Terbium 65	66 Dy Dysprosium 66	67 Ho Holmium 67	68 Er Erbium 68	69 Tm Thulium 69	70 Yb Ytterbium 70	71 Lu Lutetium 71	72 Hf Hafnium 72	73 Ta Tantalum 73	74 W Tungsten 74	75 Re Rhenium 75	76 Os Osmium 76	77 Ir Iridium 77	78 Pt Platinum 78	79 Au Gold 79	80 Hg Mercury 80	81 Tl Thallium 81	82 Pb Lead 82	83 Bi Bismuth 83	84 Po Polonium 84	85 At Astatine 85	86 Rn Radon 86	87 Fr Francium 87	88 Ra Radium 88	89 Ac Actinium 89	90 Th Thorium 90	91 Pa Protactinium 91	92 U Uranium 92	93 Np Neptunium 93	94 Pu Plutonium 94	95 Am Americium 95	96 Cm Curium 96	97 Bk Berkelium 97	98 Cf Californium 98	99 Es Einsteinium 99	100 Fm Fermium 100	101 Md Mendelevium 101	102 No Nobelium 102	103 Lr Lawrencium 103	104 Rf Rutherfordium 104	105 Db Dubnium 105	106 Sg Seaborgium 106	107 Bh Bohrium 107	108 Hs Hassium 108	109 Mt Meitnerium 109	110 Ds Darmstadtium 110	111 Rg Roentgenium 111	112 Cn Copernicium 112	113 Nh Nihonium 113	114 Fl Flerovium 114	115 Mc Moscovium 115	116 Lv Livermorium 116	117 Ts Tennessine 117	118 Og Oganesson 118

140 Ce Cerium 58	141 Pr Praseodymium 59	142 Nd Neodymium 60	143 Pm Promethium 61	144 Sm Samarium 62	145 Eu Europium 63	146 Gd Gadolinium 64	147 Tb Terbium 65	148 Dy Dysprosium 66	149 Ho Holmium 67	150 Er Erbium 68	151 Tm Thulium 69	152 Yb Ytterbium 70	153 Lu Lutetium 71
---------------------------	---------------------------------	------------------------------	-------------------------------	-----------------------------	-----------------------------	-------------------------------	----------------------------	-------------------------------	----------------------------	---------------------------	----------------------------	------------------------------	-----------------------------

a	X	b
---	---	---

a = relative atomic mass
 X = atomic symbol
 b = proton (atomic) number

71 Lanthanoid series
 103 Actinoid series

The volume of one mole of any gas is 24 dm³ at room temperature and pressure (r.t.p.).

Section A (50 marks)

Answer ALL the questions in this section in the spaces provided.

- A1 10 cm³ of ethanoic acid of unknown concentration is titrated with 0.10 mol/dm³ of aqueous sodium hydroxide. It was found that 20 cm³ of the sodium hydroxide solution was required for the neutralisation to be completed.
- (a) (i) Write a balanced chemical equation for the reaction between ethanoic acid and sodium hydroxide.
[1]
- (ii) Calculate the concentration of the ethanoic acid used in the above titration.

[2]
- (iii) The formula to calculate the pH of a solution is:
 $\text{pH} = -\lg [\text{H}^+]$
- pH is the negative logarithm to base 10 of the concentration of hydrogen ions.
- For example, if the concentration of H⁺ ions is 0.1 mol/dm³,
 Then $\text{pH} = -\lg [0.1]$
 $= 1$
- It is found that the pH value of 0.1 mol/dm³ ethanoic acid solution is higher than 1.

Using the information above, suggest a reason why the pH is more than 1.

.....

.....

.....

.....[1]

- (b) The titration curves below show the changes in pH that occurs when a strong acid and a weak acid is titrated with sodium hydroxide respectively.

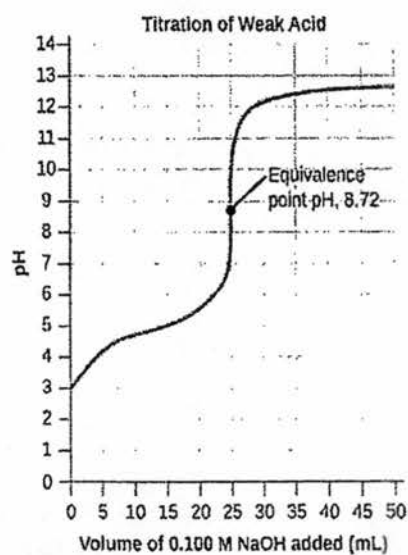
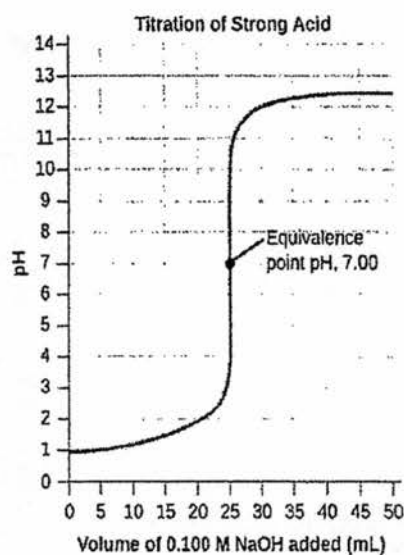

The **equivalence point** is the point where the acid is neutralised by the alkali.

- (i) Describe **two key differences** in the two titration curves illustrated above other than the difference in the pH values at the equivalence point.

.....

.....

.....

.....[2]

- (ii) What does the pH values at the equivalence points of the two titrations suggest about the nature of the salt formed in each of the two titrations?

.....

.....

.....[1]

[Total : 7m]

- A2 Michael read the following article featured in a newspaper recently. It is about increasing global temperatures due to global warming, grounding planes at the airport.

How higher temperatures affect flying

As temperatures increase, air density decreases, which reduces lift and makes it harder for airplanes to take off. To address this, airlines could reduce airplane weight (by loading fewer passengers and less fuel or cargo) or schedule departures for cooler periods of the day.

LOWER TEMPERATURES

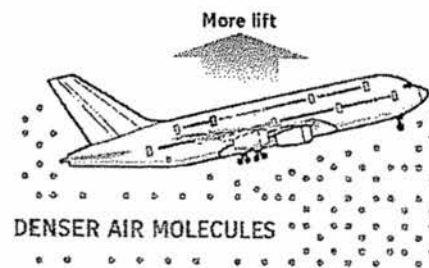

Shorter takeoff runs



HIGHER TEMPERATURES

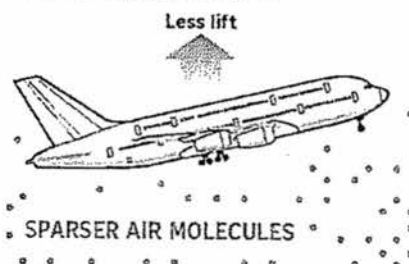

Longer takeoff runs

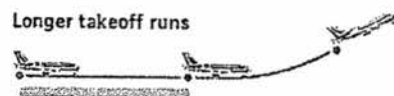

Source: NYTIMES STRAITS TIMES GRAPHICS

- (a) Michael explained that the increase in temperature caused the air molecules to disintegrate leading to fewer molecules per unit volume.

Explain, using Kinetic Particle Theory,

- (i) the correct reason for the sparser air molecules.

.....
.....
.....
.....[2]

- (ii) how cooler periods of the day allow more lift for the airplane to take off.

.....
.....
.....
.....[2]

- (b) One other way of reducing airplane weight is to use carbon fibre (or graphite fibre) to make the wings, as the material could be moulded into a desirable shape.

Explain, using bonding and structure, why graphite can be easily moulded.

.....
.....
.....
.....[2]

- (c) Environmental groups think that the shrinking of the ice caps is the result of global warming. Satellite images are used to show the area of Arctic sea ice as shown in the diagram below.

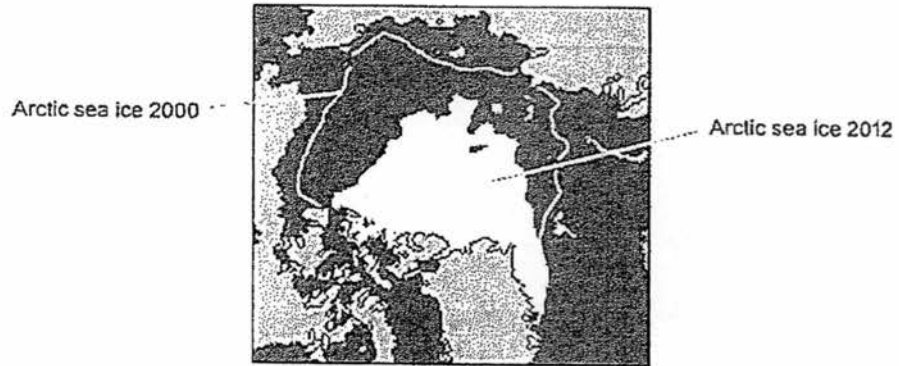

Photograph: National Snow and Ice Data Centre, Colorado.

- (i) Give **one** consequence of the reduction of Arctic sea ice.

.....
[1]

- (ii) Describe one possible source of global warming that has led to the reduction of Arctic ice.

.....

[1]

- (iii) Scientists are currently developing a process called **carbon capture and storage (CCS)**.

This will reduce the problem of global warming. There are three main steps to **CCS**. **Firstly**, carbon dioxide is trapped and separated from other gases produced in coal-powered electricity plants. The captured carbon dioxide is transported to a storage location. The carbon dioxide is then stored far away from the atmosphere (underground or deep in the ocean).

Suggest **one** reason why some scientists do not support the use of **CCS**. Use the information above to help you answer.

.....

[1]
 [Total : 9m]

- A3** The following equations show the reactions of some metals and aqueous metal ions.



- (a) Place the metals in the order of decreasing reactivity.

.....[1]

- (b) Identify the strongest oxidising agent among the metals and aqueous metal ions shown in the equations. Explain your answer in terms of electrons.

.....

[2]

- (c) Name the type of reaction shown by the equations. State one observation for the reaction between zinc and aqueous iron(II) ions.

.....
[2]

[Total : 5m]

- A4** Dilute hydrogen peroxide, H_2O_2 , decomposes to give oxygen and water when a catalyst is added.

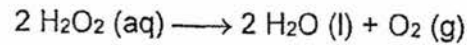
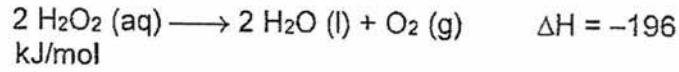

- (a) Which other method besides changing concentration, can increase the rate of decomposition of dilute hydrogen peroxide.

.....[1]

- (b) Explain, in terms of collision theory, how your answer in (a) increased the rate of decomposition of dilute hydrogen peroxide.

.....

[2]

- (c) Draw a fully labeled energy profile diagram to show the catalysed and uncatalysed decomposition of dilute hydrogen peroxide.

[3]

[Total : 6m]

- A5 The chemical compound, hydrazine (N_2H_4) is used as a rocket fuel propellant. When burned, nitrogen and water are produced as shown in the following equation:

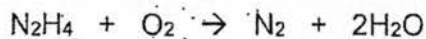

- (a) Draw a 'dot and cross' diagram for hydrazine, showing only the valence shell electrons.

[2]

- (b) Explain, using bonding and structure, why hydrazine exists as a liquid while water is in gaseous state at 100°C .

.....

 [2]

- (c) When 5 tonnes of hydrazine were burned in the rocket reaction chamber, 104000 kJ of energy were released. Calculate the enthalpy change per mole for this reaction.
 (1 tonne = 1000 kg)

[2]

[Total : 6m]

- A6 In the Haber process, the percentage of ammonia present at equilibrium at different temperatures and pressures is shown in the table below.

Ammonia present at equilibrium (%)

Temperature Pressure	100°C	200°C	300°C	400°C	500°C
10 atm	88.2	50.7	14.7	3.9	1.2
25 atm	91.7	63.6	27.4	8.7	2.9
50 atm	94.5	74.0	39.5	15.3	5.6
100 atm	96.7	81.7	52.5	25.2	10.6
200 atm	98.4	89.0	66.7	38.8	18.3
400 atm	99.4	94.6	79.7	55.4	31.9
1000 atm	99.9	98.3	92.6	79.8	57.5

Use information from the table to answer the following questions.

- (a) Describe how the composition of ammonia varies with the conditions of pressure and temperature.

.....
[2]

- (b) (i) State the temperature and pressure that will produce the highest percentage of ammonia at equilibrium.

.....[1]

- (ii) Explain why these conditions are not used commercially in industries.

.....

[2]

- (c) Calculate the mass of ammonia produced at equilibrium when 1 tonne of nitrogen was reacted with excess hydrogen at 200 atm and 400 °C.
[1tonne = 1000kg]

[3]

[Total : 8m]

- A7 (a) The flow chart below shows a series of reactions carried out to produce vinegar, ethanoic acid.

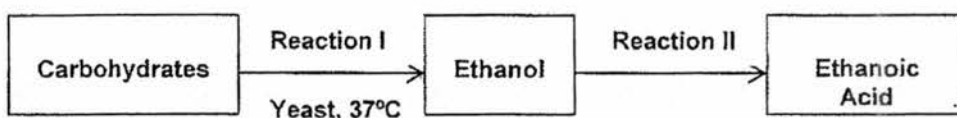

- (i) State the name of Reaction I.
.....[1]
- (ii) Write a balanced chemical equation for Reaction I.
.....[1]
- (iii) State the reagents and conditions required in Reaction II to react with ethanol to form ethanoic acid.
.....[1]

- (iv) Methanoic acid reacts with ethanol to form a sweet-smelling compound, compound Z, when heated with concentrated sulfuric acid. State the name of compound Z and draw its full structural formula in the table below. Circle the functional group of compound Z. [3]

Name of Compound Z:
Full structural formula:

- (b) Ethanol is being increasingly used in many areas such as for beverages, fuel and solvents. Describe **two** disadvantages and **one** advantage of the manufacturing process of ethanol by fermentation over the addition reaction of ethene with steam.

NAME: _____

() CLASS _____

Section B (30m)

Answer all **three** questions from this section. The last question is in the form of an either / or and only **one** of the alternatives should be attempted.

Write your answers in the space provided.

B8 Table 8.1 shows some information on the chlorides of elements in Period 3.

Proton number of element	Formula of the chloride	Melting point of the chloride/ °C	Type of bonding in the chloride
11	NaCl	801	Ionic
12	MgCl ₂	714	Ionic
13	AlCl ₃	193	Covalent
14	SiCl ₄	-69	Covalent
15	PCl ₃	-94	Covalent
16	S ₂ Cl ₂	-80	Covalent
17	Cl ₂	-102	Covalent

Table 8.1

- (a) State the relationship between the proton number of the elements and the melting point of their chlorides.

.....
[1]

- (i) Explain in terms of the number of protons and electrons, why the ionic radius of the metal ion is always smaller than its atomic radius.

.....
.....
.....[2]

- (ii) The high electrical conductivity of copper makes it a very useful element for making electrical components. Apart from its high cost, suggest why copper is **not** usually used for overhead electrical cables.

.....
.....[1]

- (iii) Give one reason why the following metals are unsuitable material for making electrical wires.

1. Calcium:
.....
2. Iron:
.....[2]

- (d) The apparatus shown was used to determine the mass of zinc in brass (an alloy of zinc and copper).

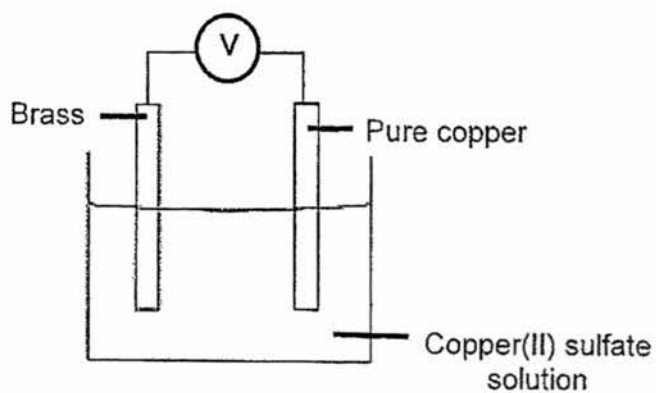

- (i) Use an arrow to show the direction of electron flow on the diagram. [1]
- (ii) Write ionic equations for the reaction occurring at the negative and positive terminals.

.....

.....[2]

[Total : 10m]

- B9 The follow apparatus can be used to carry out the electrolysis of dilute aqueous sulfuric acid.

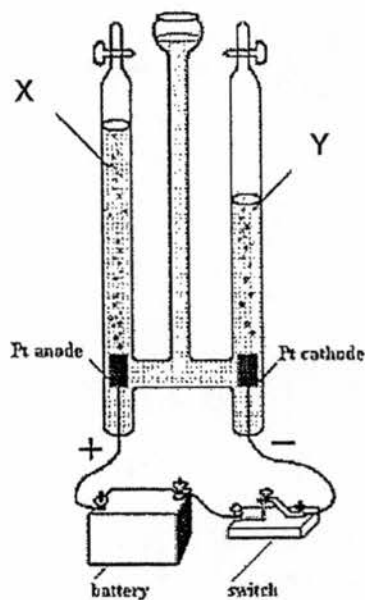

Experiment I

- (a) Write the balanced ionic equations for the anode and cathode reactions respectively.

.....
[2]

- (b) Suggest one reason why platinum electrodes are preferred over graphite electrodes in this electrolysis.

.....
[1]

- (c) Explain, with the help of the overall equation for this electrolysis, why the relative volumes of X:Y is approximately 1:2.

.....
.....
.....
.....[2]

- (d) In a separate experiment II, the same setup is used as experiment I, but concentrated hydrochloric acid is used as the electrolyte in place of dilute aqueous sulfuric acid.

State and explain **one similarity** and **two differences** in the observations made between experiments I and II.

.....
.....
.....
.....
.....
.....[3]

[Total : 8m]

Either

B10 Short sections of the structural formula of two polymers are shown below.

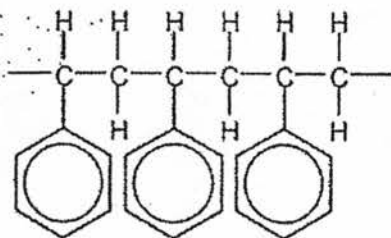

polymer A

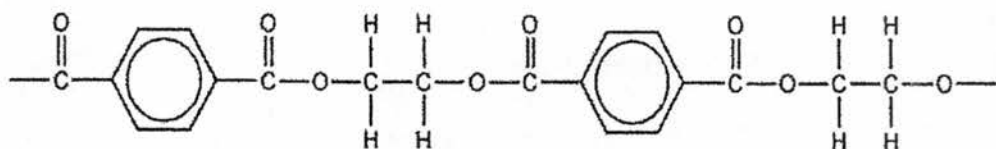

polymer B

- (a) Draw the structural formula of all the monomers that react to form the two polymers above and state the type of polymer that it is.

Monomer(s) from polymer A:

Type of polymer: _____

Monomer(s) from polymer B:

Type of polymer: _____

[4]

- (b) (i) Polymer B was broken down into its respective monomers, which are miscible liquids. Describe the technique that can be used to separate the monomers of Polymer B.

.....
.....
.....[2]

- (ii) Describe chemical tests to identify the monomers present in Polymer B.

.....
.....
.....
.....
.....
.....
.....
.....[2]

- (c) Describe a pollution problem that can be caused by the disposal of these polymers.

.....
.....
.....[2]

[Total: 10m]

OR

- B10** The table below gives values for the energy change of combustion (ΔH) for some common alkanes and alcohols used as fuels:

Substance (fuel)	Combustion Reaction	ΔH (kJ mol ⁻¹)
ethane	$2\text{C}_2\text{H}_6(\text{g}) + 7\text{O}_2(\text{g}) \rightarrow 4\text{CO}_2(\text{g}) + 6\text{H}_2\text{O}(\text{l})$	$\Delta H = -1560$
butane	$2\text{C}_4\text{H}_{10}(\text{g}) + 13\text{O}_2(\text{g}) \rightarrow 8\text{CO}_2(\text{g}) + 10\text{H}_2\text{O}(\text{l})$	$\Delta H = -2874$
octane	$2\text{C}_8\text{H}_{18}(\text{g}) + 25\text{O}_2(\text{g}) \rightarrow 16\text{CO}_2(\text{g}) + 18\text{H}_2\text{O}(\text{l})$	$\Delta H = -5460$
ethanol	$\text{C}_2\text{H}_5\text{OH}(\text{l}) + 3\text{O}_2(\text{g}) \rightarrow 2\text{CO}_2(\text{g}) + 3\text{H}_2\text{O}(\text{l})$	$\Delta H = -1368$
butan-1-ol (1-butanol)	$\text{C}_4\text{H}_9\text{OH}(\text{l}) + 6\text{O}_2(\text{g}) \rightarrow 4\text{CO}_2(\text{g}) + 5\text{H}_2\text{O}(\text{l})$	$\Delta H = -2671$

- (a) Using information from the table, describe the relationship between the number of carbon atoms in alkanes and enthalpy for the combustion.
-
-
-
-[2]
- (b) Based on the information given in the above table, what conclusions can you draw about the enthalpy change of combustion for the alkanes and alcohols?
-
-
-
-[2]

- (c) Explain, using bond breaking and bond formation, why the combustion of ethane is an exothermic reaction.

.....
.....
.....
.....[2]

- (d) Comparing butane and butan-1-ol, calculate which substance would give a better energy output when 10 kg of each fuel is used.

[3]

- (e) State a reason for butan-1-ol as being a preferred fuel compared to butane.

.....
.....
.....[1]

[Total : 10m]