

*Visit*

**FREETESTPAPER.com**

*for more papers*



Website: [freetestpaper.com](http://www.freetestpaper.com)



[Facebook.com/freetestpaper](https://www.facebook.com/freetestpaper)



[Twitter.com/freetestpaper](https://www.twitter.com/freetestpaper)

Name

Reg. No

Class



MAYFLOWER SECONDARY SCHOOL MAYFLOWER SECONDARY SCHOOL MAYFLOWER SECONDARY SCHOOL MAYFLOWER SECONDARY SCHOOL MAYFLOWER SECONDARY SCHOOL  
MAYFLOWER SECONDARY SCHOOL MAYFLOWER SECONDARY SCHOOL MAYFLOWER SECONDARY SCHOOL MAYFLOWER SECONDARY SCHOOL MAYFLOWER SECONDARY SCHOOL  
MAYFLOWER SECONDARY SCHOOL MAYFLOWER SECONDARY SCHOOL MAYFLOWER SECONDARY SCHOOL MAYFLOWER SECONDARY SCHOOL MAYFLOWER SECONDARY SCHOOL  
MAYFLOWER SECONDARY SCHOOL MAYFLOWER SECONDARY SCHOOL MAYFLOWER SECONDARY SCHOOL MAYFLOWER SECONDARY SCHOOL MAYFLOWER SECONDARY SCHOOL  
MAYFLOWER SECONDARY SCHOOL MAYFLOWER SECONDARY SCHOOL MAYFLOWER SECONDARY SCHOOL MAYFLOWER SECONDARY SCHOOL MAYFLOWER SECONDARY SCHOOL  
MAYFLOWER SECONDARY SCHOOL MAYFLOWER SECONDARY SCHOOL MAYFLOWER SECONDARY SCHOOL MAYFLOWER SECONDARY SCHOOL MAYFLOWER SECONDARY SCHOOL  
MAYFLOWER SECONDARY SCHOOL MAYFLOWER SECONDARY SCHOOL MAYFLOWER SECONDARY SCHOOL MAYFLOWER SECONDARY SCHOOL MAYFLOWER SECONDARY SCHOOL  
MAYFLOWER SECONDARY SCHOOL MAYFLOWER SECONDARY SCHOOL MAYFLOWER SECONDARY SCHOOL MAYFLOWER SECONDARY SCHOOL MAYFLOWER SECONDARY SCHOOL

# 4EX

## PURE CHEMISTRY

6092/01

Paper 1 [40 Marks]

PRELIMINARY EXAMINATION

September 2019

1 hour

Additional Materials

Approved Calculator

Multiple Choice Answer Sheet

Soft clean eraser

Soft pencil (type B or HB is recommended)

### INSTRUCTIONS TO CANDIDATES:

**Do not start reading the questions until you are told to do so.**

Do not use staples, paper clips, highlighters, glue or correction fluid.

Write your name, class, and index number on the OTAS provided.

### INFORMATION FOR CANDIDATES:

There are forty questions on this paper. Answer **all** questions.

For each question there are four possible answers **A, B, C** and **D**.

Choose the **one** you consider correct and record your choice in **soft pencil** on the **OTAS**.

**Read the instructions on the OTAS very carefully.**

Each correct answer will score one mark. A mark will not be deducted for a wrong answer.

Any rough working should be done in this booklet.

Page 18 is a blank page

A copy of the Periodic Table is printed on page 19

---

This question paper consists of **19** printed pages.

---

### Paper 1: Multiple Choice Questions (40 marks)

Answer **all** the questions in the OTAS provided.

- 1 Which of the following shows the most suitable set-up to purify gas X using liquid Y?

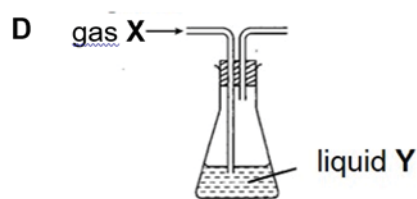
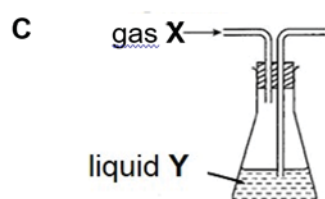
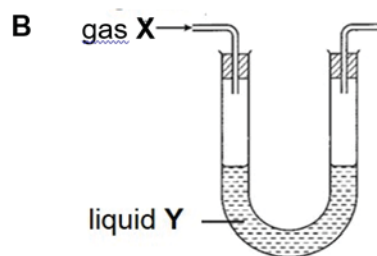
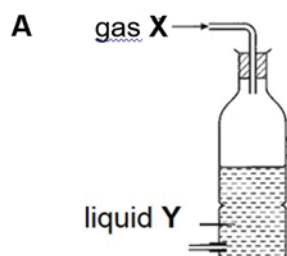

- 2 Two experiments were carried out.

In each experiment, the gas evolved was tested with damp blue litmus paper and damp red litmus paper.

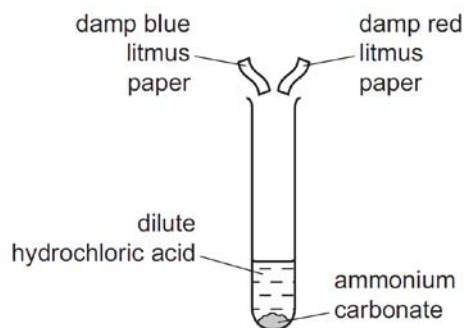

experiment 1

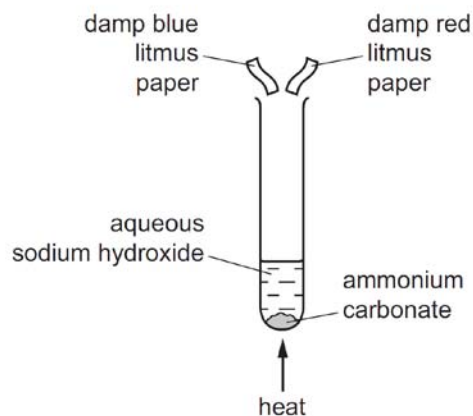

experiment 2

Which row correctly shows the colour of both the pieces of litmus paper at the end of each experiment?

	experiment 1	experiment 2
<b>A</b>	blue	blue
<b>B</b>	blue	red
<b>C</b>	red	blue
<b>D</b>	red	red

- 3 Which substance would diffuse most quickly?
- A carbon dioxide at 0 °C  
 B carbon dioxide at 25 °C  
 C neon at 0 °C  
 D neon at 25 °C
- 4 A paper chromatography experiment is carried out to find an  $R_f$  value for  $Fe^{3+}(aq)$ . The result is shown.

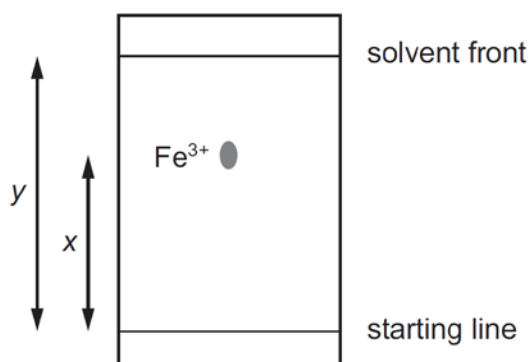

To make the spot containing  $Fe^{3+}(aq)$  more visible, the paper is sprayed with aqueous sodium hydroxide so that a precipitate of iron(III) hydroxide forms.

Under the conditions of the experiment, the  $R_f$  of  $Fe^{3+}(aq)$  is given by **(a)** and the colour of the precipitate is **(b)**.

	<b>(a)</b>	<b>(b)</b>
<b>A</b>	$x/y$	red-brown
<b>B</b>	$x/y$	green
<b>C</b>	$y/x$	red-brown
<b>D</b>	$y/x$	green

- 5 Which statement about chlorine atoms and chloride ions is correct?
- A They are both isotopes of chlorine.  
 B They have the same number of protons.  
 C They have the same physical properties.  
 D They undergo the same chemical reactions.

- 6 **X** represents the element of atomic number 8 and **Y** represents the element of atomic number 19.

The two elements react together to form a compound.

Which row is correct for the compound formed?

	formula	bonding
<b>A</b>	<b>X<sub>2</sub>Y</b>	covalent
<b>B</b>	<b>X<sub>2</sub>Y</b>	ionic
<b>C</b>	<b>Y<sub>2</sub>X</b>	covalent
<b>D</b>	<b>Y<sub>2</sub>X</b>	ionic

- 7 Some ionic compounds can have covalent character.

In general, the greater the positive charge of the cation, the more it causes the electron cloud of the anion to be distorted, causing covalent behavior.

In addition, if the size of the anion is larger, the electron cloud is more easily distorted compared to one that is smaller.

According to the information provided, which compound below exhibits the **greatest** covalent character?

- A** aluminum iodide
  - B** calcium chloride
  - C** lithium fluoride
  - D** sodium oxide
- 8 Solid copper metal, aqueous copper(II) sulfate, solid graphite and molten magnesium chloride will all conduct electricity.

Which pair will conduct electricity because they both contain mobile electrons?

- A** aqueous copper(II) sulfate and molten magnesium chloride
- B** aqueous copper(II) sulfate and solid copper metal
- C** molten magnesium chloride and solid graphite
- D** solid copper metal and solid graphite

9 Which ionic equation best represents the reaction between aqueous potassium hydroxide with dilute nitric acid?

- A  $\text{H}^+(\text{aq}) + \text{OH}^-(\text{aq}) \rightarrow \text{H}_2\text{O}(\text{l})$
- B  $\text{K}^+(\text{aq}) + \text{NO}_3^-(\text{aq}) \rightarrow \text{KNO}_3(\text{aq})$
- C  $\text{K}^+(\text{aq}) + \text{HNO}_3(\text{aq}) \rightarrow \text{KNO}_3(\text{aq}) + \text{H}^+(\text{aq})$
- D  $\text{KOH}(\text{aq}) + \text{H}^+(\text{aq}) \rightarrow \text{K}^+(\text{aq}) + \text{H}_2\text{O}(\text{l})$

10 The characteristics of a gas, **G**, are given.

- **G** reduces copper(II) oxide to a pink-brown solid.
- 1.4 g of **G** has a volume of  $1.2 \text{ dm}^3$  at room temperature and pressure.

What is **G**?

- A carbon monoxide
- B hydrogen gas
- C nitrogen gas
- D nitrogen monoxide

11 In an experiment,  $1 \text{ cm}^3$  of a gaseous hydrocarbon, **Z**, requires  $5 \text{ cm}^3$  of oxygen for complete combustion to give  $3 \text{ cm}^3$  of carbon dioxide. All gas volumes are measured at room temperature and pressure.

Which formula represents **Z**?

- A  $\text{C}_2\text{H}_2$       B  $\text{C}_2\text{H}_4$       C  $\text{C}_3\text{H}_6$       D  $\text{C}_3\text{H}_8$

12 Analysis of a sample of a substance has the following composition by mass.

- percentage by mass of carbon is 41.9%
- percentage by mass of hydrogen is 3.1%
- percentage by mass of chlorine is 55%

What is its molecular formula?

- A  $\text{C}_3\text{H}_6\text{Cl}_4$
- B  $\text{C}_4\text{H}_9\text{Cl}_4$
- C  $\text{C}_8\text{H}_4\text{Cl}_9$
- D  $\text{C}_9\text{H}_8\text{Cl}_4$

[Turn over

- 13 The diagrams show an electrolysis experiment using inert electrodes.

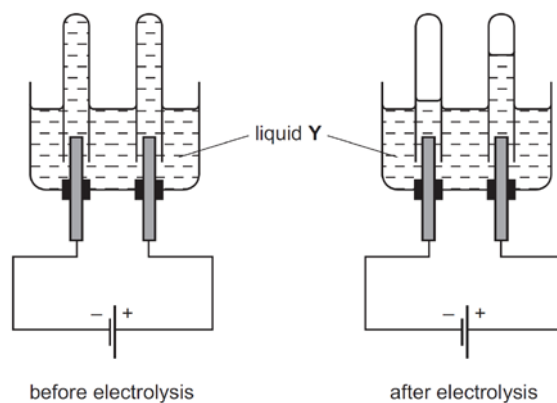

What could liquid Y be?

- A aqueous copper(II) sulfate
  - B concentrated aqueous sodium chloride
  - C dilute sulfuric acid
  - D ethanol
- 14 During the electroplating of a metal spoon using silver,
1. the anode is the silver metal.
  2. the spoon is made the cathode.
  3. the electrolyte used is aqueous silver nitrate.
  4. the concentration of the electrolyte decreases during electroplating.

Which of the above statements are true?

- A 1, 2 and 3 only
- B 1 and 3 only
- C 1, 3 and 4 only
- D 2 and 3 only

15 In which circuit does the bulb light?

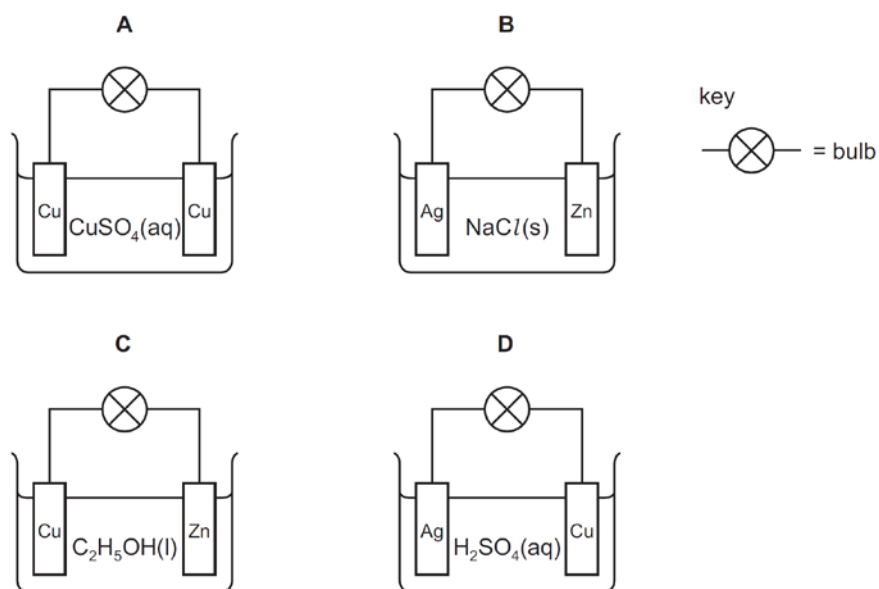

16 Below is an energy profile diagram for a chemical reaction showing the energy changes I, II, III and IV.

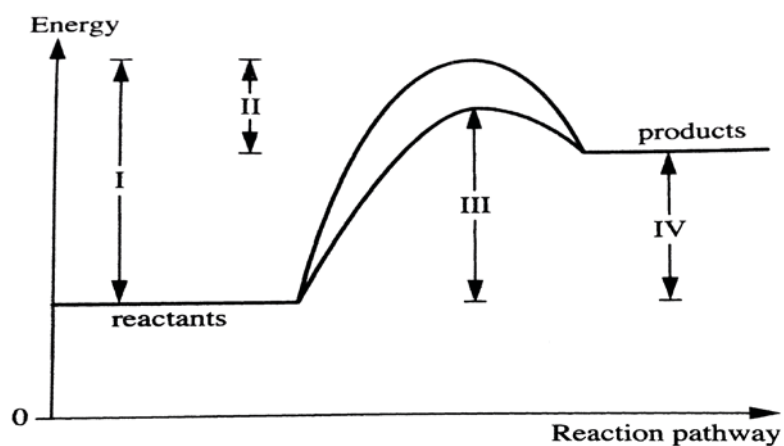

Which of the following energy changes indicates the activation energy for the catalyzed reaction?

- A**      **I**      **B**      **II**      **C**      **III**      **D**      **IV**

[Turn over

- 17 Compound **Y** reacts with oxygen and this reaction has a positive enthalpy change of reaction.

What information can be deduced about **Y** and its reaction with oxygen?

- A Compound **Y** can be used as a fuel.
- B In the reaction the energy absorbed to break bonds is greater than the energy released when bonds are made.
- C In the reaction the products are at a lower energy level than the reactants.
- D The reaction could be combustion.

- 18 A student wrote two conclusions about calcium carbonate.

conclusion 1: The reaction with dilute hydrochloric acid is faster with powdered calcium carbonate than with large pieces of calcium carbonate.

conclusion 2: Grinding large pieces of calcium carbonate to form powder increases the particle size.

Which statement is correct?

- A Both conclusions are correct and conclusion 2 explains conclusion 1.
- B Both conclusions are correct but conclusion 2 does not explain conclusion 1.
- C Conclusion 1 is correct but conclusion 2 is not correct.
- D Conclusion 2 is correct but conclusion 1 is not correct.

- 19 Magnesium reacts with dilute sulfuric acid.  
Two experiments were carried out.

experiment 1: 24.0 g of magnesium was reacted with 100 cm<sup>3</sup> of 1.0 mol/dm<sup>3</sup> sulfuric acid.

experiment 2: 24.0 g of magnesium was reacted with 100 cm<sup>3</sup> of 2.0 mol/dm<sup>3</sup> sulfuric acid.

In each experiment the volume of hydrogen was measured at various times. The results were plotted on a graph.

Which graph is correct?

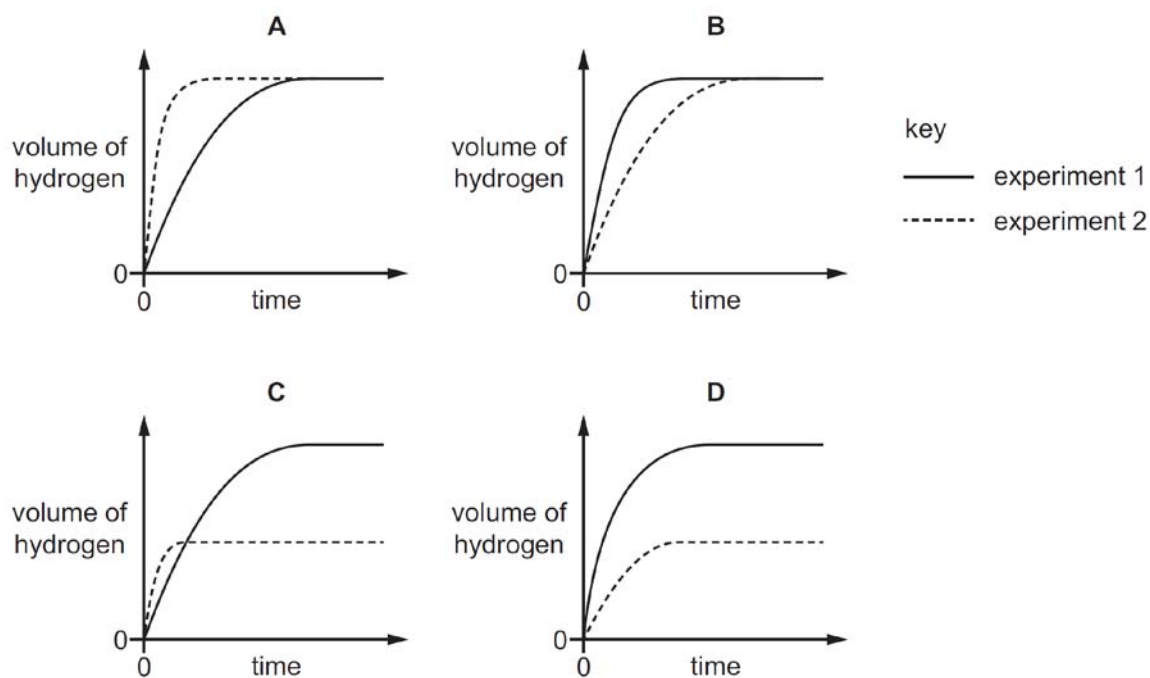

- 20 Which reaction does **not** involve oxidation or reduction?

- A  $2\text{H}_2 + \text{O}_2 \rightarrow 2\text{H}_2\text{O}$   
 B  $\text{Fe}^{2+} \rightarrow \text{Fe}^{3+} + \text{e}^-$   
 C  $2\text{H}^+ + \text{CO}_3^{2-} \rightarrow \text{H}_2\text{O} + \text{CO}_2$   
 D  $\text{CuO} + \text{H}_2 \rightarrow \text{Cu} + \text{H}_2\text{O}$

[Turn over

- 21 The reaction between iron(II) ions and manganate(VII) ions is represented by the following equation.



Which one of the following statements is correct?

- A  $\text{Fe}^{2+}$  gained electrons to form  $\text{Fe}^{3+}$ .  
 B  $\text{Fe}^{2+}$  is a reducing agent.  
 C The oxidation state of hydrogen had decreased.  
 D The oxidation state of manganese has increased.
- 22 The graph below shows the pH changes when  $0.1 \text{ mol/dm}^3$  of aqueous ammonia solution is added to  $50.0 \text{ cm}^3$  of  $0.1 \text{ mol/dm}^3$  of hydrochloric acid.

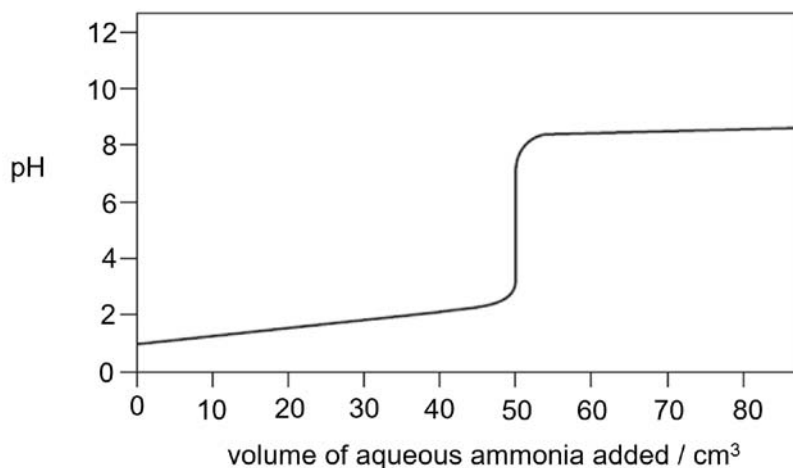

Which of the following indicators is **not** suitable for use in determining the endpoint for the neutralisation reaction above?

	indicator	pH range of indicator
A	bromothymol blue	6.0 – 7.6
B	bromothymol red	5.2 – 6.8
C	methyl orange	3.1 – 4.4
D	phenolphthalein	8.3 – 10.0

- 23 Which of the following statements about oxides is correct?

- A A basic oxide is an oxide of a non-metal.  
 B Acidic oxides contain ionic bonds.  
 C Amphoteric oxides contain a metal.  
 D Basic oxides are always gases.

- 24 Which of the following reactants when mixed produces a salt that can be obtained as a residue after filtration?
- A aqueous copper(II) sulfate and aqueous sodium nitrate  
 B aqueous sodium hydroxide and dilute nitric acid  
 C dilute sulfuric acid and aqueous barium nitrate  
 D zinc metal and dilute hydrochloric acid
- 25 A sample of an alloy containing two metals was subjected to the following tests. What are the two metals present in the alloy?

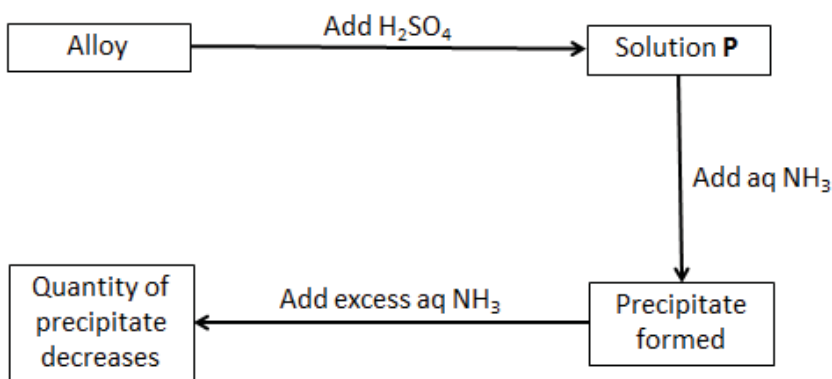

- A copper and zinc  
 B iron and copper  
 C iron and lead  
 D iron and zinc
- 26 Element X has the following properties.
- forms  $\text{XF}_3$  when heated with fluorine
  - forms  $\text{XSO}_4$  when reacted with dilute sulfuric acid

To which part of the Periodic Table does Q belong?

- A Group II  
 B Group III  
 C Group IV  
 D Transition metals

27 Caesium, Cs, is an element in the same group of the Periodic Table as lithium, sodium and potassium. Some statements of caesium metal is given below.

- It reacts explosively with cold water.
- It forms a soluble carbonate salt.
- It forms a carbonate with a formula of  $\text{CsCO}_3$ .
- It can be extracted via electrolysis of concentrated aqueous  $\text{CsCl}$ .

How many statements about caesium are likely to be **wrong**?

**A**      1              **B**      2              **C**      3              **D**      4

28 Using the apparatus shown, chlorine is passed through the tube. After a short time, coloured substances are seen at **P**, **Q** and **R**.

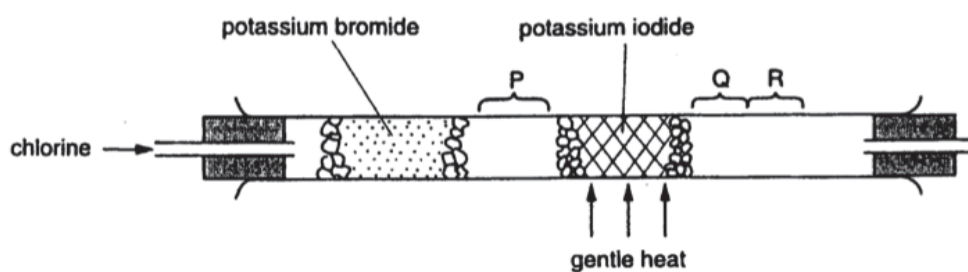

What would be observed at P, Q and R?

	<b>P</b>	<b>Q</b>	<b>R</b>
<b>A</b>	green gas	violet vapour	black solid
<b>B</b>	green gas	red-brown vapour	violet vapour
<b>C</b>	red-brown vapour	violet vapour	black solid
<b>D</b>	violet vapour	red-brown vapour	red-brown vapour

- 29 The following table refers to four metals and some of their compounds.

Metal	Action of dilute sulfuric acid on metal	Effect of carbon on heated oxide	Action of metal on a solution of the sulfate of H
E	hydrogen evolved	reduced	no reaction
F	no reaction	reduced	no reaction
G	hydrogen evolved	no action	metal H formed
H	hydrogen evolved	no action	no reaction

Which of the following lists the metals in order of **decreasing** reactivity?

- A**      F                      E                      H                      G  
**B**      G                      H                      E                      F  
**C**      G                      H                      F                      E  
**D**      H                      G                      E                      F

- 30 Which statement about the extraction of iron in the blast furnace is correct?

- A** Carbon reacts with carbon dioxide to produce carbon monoxide  
**B** Iron(III) oxide reacts with carbon dioxide to produce molten iron.  
**C** Limestone is added to remove basic impurities.  
**D** Molten iron floats on molten slag at the bottom of the furnace.

- 31 A block of magnesium and a block of copper were attached to underground steel tanks, **X** and **Y** as shown below.

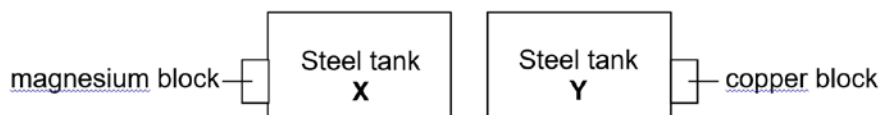

Which pair of equation would represent the reactions that would occur at tanks **X** and **Y**?

	Steel tank X	Steel tank Y
<b>A</b>	$\text{Fe} \rightarrow \text{Fe}^{2+} + 2\text{e}$	$\text{Cu} \rightarrow \text{Cu}^{2+} + 2\text{e}$
<b>B</b>	$\text{Fe} \rightarrow \text{Fe}^{2+} + 2\text{e}$	$\text{Fe} \rightarrow \text{Fe}^{2+} + 2\text{e}$
<b>C</b>	$\text{Mg} \rightarrow \text{Mg}^{2+} + 2\text{e}$	$\text{Cu} \rightarrow \text{Cu}^{2+} + 2\text{e}$
<b>D</b>	$\text{Mg} \rightarrow \text{Mg}^{2+} + 2\text{e}$	$\text{Fe} \rightarrow \text{Fe}^{2+} + 2\text{e}$

[Turn over

- 32 A recycling company is to decide on which metals to recycle.

Based on the information provided in the table below, for which metal is the company **least** likely to recycle?

	Abundance of raw metal/metal ore on Earth	Ease of extracting metal from the Earth	Cost of preparing the used metal for recycling
<b>A</b>	High	Low	Moderate
<b>B</b>	Low	High	High
<b>C</b>	Low	High	Low
<b>D</b>	Moderate	High	High

- 33 An experiment was set up as shown below to investigate the rate of rusting under different conditions.

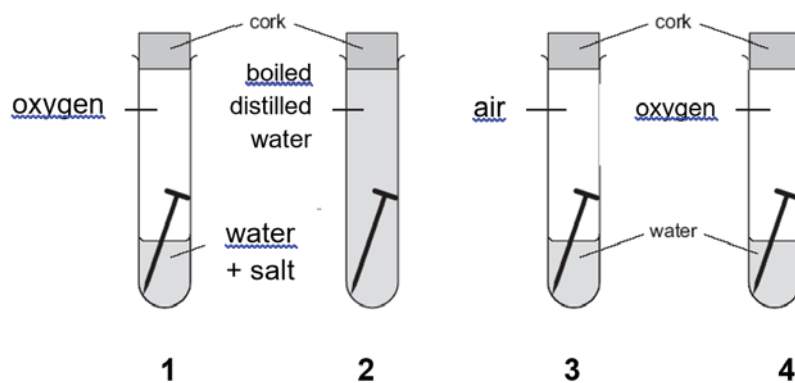

Predict the order of the test-tubes in which rust would first appear.

- A** 1, 3, 4, 2
- B** 1, 4, 3, 2
- C** 2, 3, 4, 1
- D** 3, 4, 1, 2

- 34 In the experiment below, an air sample is bubbled into excess sodium hydroxide solution, then passed over excess copper and finally into some anhydrous copper(II) sulfate.

What is the constituent of the gas that came out from **Q**?

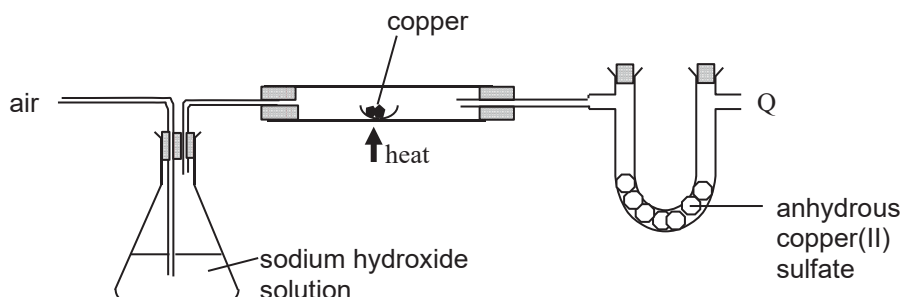

- A nitrogen, noble gases  
 B nitrogen, noble gases and carbon dioxide  
 C nitrogen, noble gases and oxygen  
 D water vapour and noble gases
- 35 Which row correctly compares carbon dioxide and methane?

	both contain carbon	both are described as a greenhouse gas	both increases the pH of water when they dissolve in it
<b>A</b>	✓	×	✓
<b>B</b>	✓	✓	×
<b>C</b>	×	✓	✓
<b>D</b>	×	✓	×

- 36 The diagrams show the structures of three hydrocarbons.

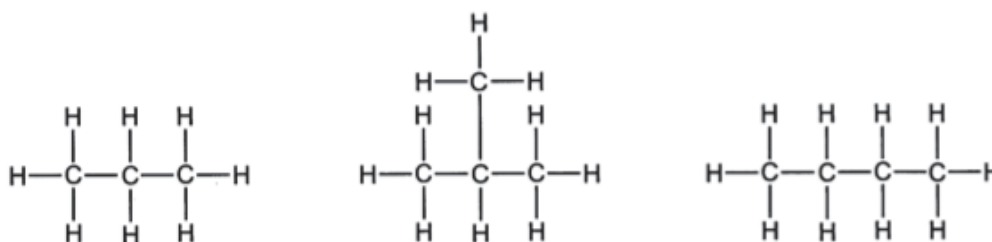

Which statement is correct for **all** three compounds?

- A They are isomers of each other.  
 B They have the same general formula.  
 C They have the same physical properties.  
 D They react with aqueous chlorine.

[Turn over

37 **Z** is a compound that:

- can be formed, as the only other product, when the alkane  $C_8H_{18}$  is cracked to produce butane
- decolourises bromine water

What is the formula of **Z**?

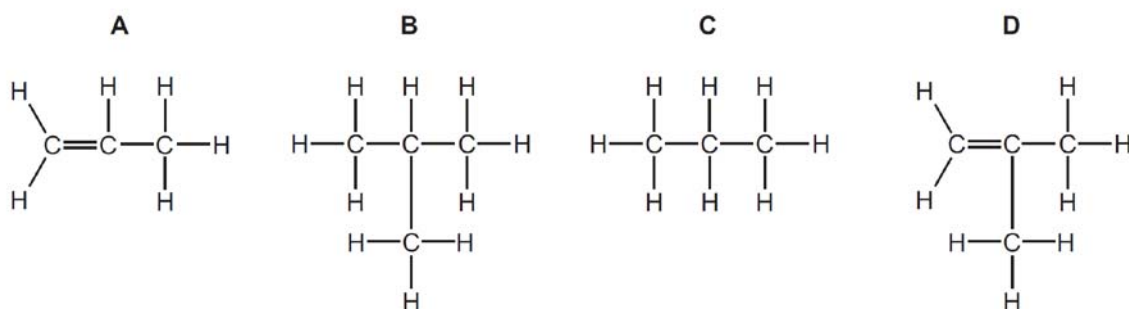

38 Under certain conditions, 1 mole of ethane reacts with 2 moles of chlorine in a substitution reaction.

What is the formula of the organic product in this reaction?

- A**  $C_2H_5Cl$   
**B**  $C_2H_4Cl_2$   
**C**  $C_2H_2Cl_4$   
**D**  $CH_2Cl_2$

39 The following reaction scheme shows the reactions of three substances, **X**, **Y** and **Z**.

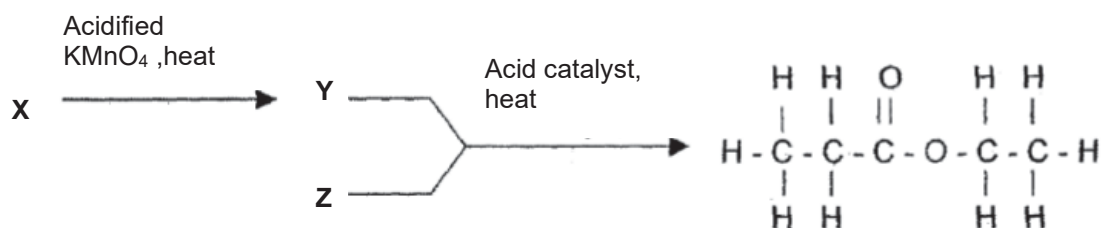

What are the molecular formulae of substances, **X**, **Y** and **Z**?

	<b>X</b>	<b>Y</b>	<b>Z</b>
<b>A</b>	$C_3H_8O$	$C_3H_6O_2$	$C_2H_6O$
<b>B</b>	$C_2H_6O$	$C_3H_6O_2$	$C_2H_6O$
<b>C</b>	$C_3H_6$	$C_3H_8O$	$C_2H_5O_2$
<b>D</b>	$C_3H_8O$	$C_4H_8O_2$	$C_2H_6O$

40 Which compounds would undergo polymerisation on their own?

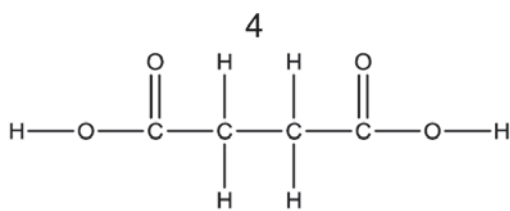
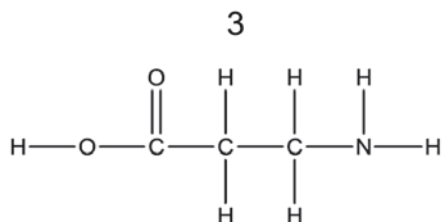
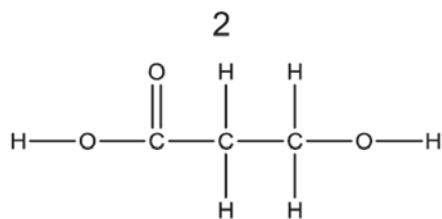
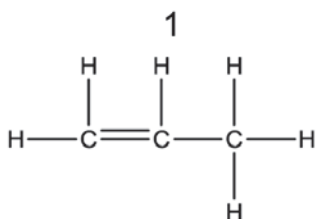

- A** 1 and 2 only  
**B** 1, 2 and 3 only  
**C** 1, 2, 3 and 4  
**D** 2 and 3 only

----- End of Paper 1 -----

[Turn over

**BLANK PAGE**



Name

Reg. No

Class



MAYFLOWER SECONDARY SCHOOL MAYFLOWER SECONDARY SCHOOL MAYFLOWER SECONDARY SCHOOL MAYFLOWER SECONDARY SCHOOL MAYFLOWER SECONDARY SCHOOL  
MAYFLOWER SECONDARY SCHOOL MAYFLOWER SECONDARY SCHOOL MAYFLOWER SECONDARY SCHOOL MAYFLOWER SECONDARY SCHOOL MAYFLOWER SECONDARY SCHOOL  
MAYFLOWER SECONDARY SCHOOL MAYFLOWER SECONDARY SCHOOL MAYFLOWER SECONDARY SCHOOL MAYFLOWER SECONDARY SCHOOL MAYFLOWER SECONDARY SCHOOL  
MAYFLOWER SECONDARY SCHOOL MAYFLOWER SECONDARY SCHOOL MAYFLOWER SECONDARY SCHOOL MAYFLOWER SECONDARY SCHOOL MAYFLOWER SECONDARY SCHOOL  
MAYFLOWER SECONDARY SCHOOL MAYFLOWER SECONDARY SCHOOL MAYFLOWER SECONDARY SCHOOL MAYFLOWER SECONDARY SCHOOL MAYFLOWER SECONDARY SCHOOL  
MAYFLOWER SECONDARY SCHOOL MAYFLOWER SECONDARY SCHOOL MAYFLOWER SECONDARY SCHOOL MAYFLOWER SECONDARY SCHOOL MAYFLOWER SECONDARY SCHOOL  
MAYFLOWER SECONDARY SCHOOL MAYFLOWER SECONDARY SCHOOL MAYFLOWER SECONDARY SCHOOL MAYFLOWER SECONDARY SCHOOL MAYFLOWER SECONDARY SCHOOL  
MAYFLOWER SECONDARY SCHOOL MAYFLOWER SECONDARY SCHOOL MAYFLOWER SECONDARY SCHOOL MAYFLOWER SECONDARY SCHOOL MAYFLOWER SECONDARY SCHOOL

# 4EX

## PURE CHEMISTRY

6092/02

Paper 2  
[80 Marks]

**PRELIMINARY EXAMINATION**  
September 2019  
**1 hour 45 minutes**

Additional Materials:  
Approved calculator

### INSTRUCTIONS TO CANDIDATES:

**Do not open this booklet until you are told to do so.**

Write your name, index number and class in the spaces at the top of this page and on any separate answer paper used.

Write in dark blue or black pen on both sides of the paper.

Do not use staples, paper clips, highlighters, glue or correction fluid.

### **Section A**

Answer **all** questions in the space provided.

### **Paper 2: Section B**

Answer **three** questions in the space provided. The last question is in the form of an either/or and only one of the alternatives should be attempted.

<i>FOR EXAMINER'S USE</i>	
Section	Marks
Paper 1 MCQ	/ 40
Paper 2: A	/ 50
<b>Paper 2: B</b>	
B 8	/ 10
B 9	/ 10
B10 Either / Or	/ 10
<b>Total</b>	<b>/ 120</b>

### INFORMATION FOR CANDIDATES:

The number of marks is given in brackets [ ] at the end of each question or part question.

A copy of the Periodic Table is printed on page **22**.

---

This question paper consists of **22** printed pages

---

Setter: Chen Yanhui Timothy

Vetter: Mdm Jarina Banu

**Section A (50 marks)**

Answer all the questions in this section in the spaces provided.

- A1 (a)** Choose from the list of gases to answer the questions.

**ammonia**  
**carbon monoxide**  
**chlorine**  
**butane**  
**hydrogen**  
**nitrogen**  
**oxygen**  
**propane**  
**sulfur dioxide**

Each gas can be used once, more than once or not at all.  
Which gas:

**(i)** burns in air to give only water  
.....[1]

**(ii)** is acidic  
.....[1]

**(iii)** has a molecule containing only 11 atoms  
.....[1]

**(iv)** Is the most abundant gas in dry air  
.....[1]

**(v)** is released when calcium hydroxide is added to soil that contains the fertilizer ammonium nitrate?  
.....[1]

- (b)** 2 gases in the list reacts to form ammonia gas in the Haber Process.

**(i)** Write a balanced chemical equation for this reaction to form ammonia  
.....[2]

(ii) List the three optimal conditions for the formation of ammonia in Haber Process.

.....  
.....[1]

[Total: 8]

**A2** Sodium and calcium hydrides react with water to form the hydroxide and hydrogen.

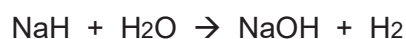

(a) (i) Deduce the general ionic equation for these reactions.

.....[1]

(ii) Hence, explain why this reaction is considered a redox reaction, in terms of oxidation state.

.....  
.....  
.....  
.....  
.....  
.....  
.....[3]

(b) Sodium is a soft metal with little catalytic activity.  
Nickel is a hard metal which is often used as a catalyst.

(i) Describe two other differences in the physical properties of sodium and nickel.

1.....  
.....  
2.....  
.....[2]

(ii) State one industrial use of nickel as a catalyst.

.....[1]

[Turn over

- (iii) Explain why an alloy of nickel and copper is less malleable than copper alone.

.....  
 .....  
 .....  
 .....[2]

[Total: 9]

- A3** James is given four samples of metals. He labelled them **W**, **X**, **Y** and **Z** and carried out two experiments. His findings were as follows:

*Experiment 1:* Oxide of **W** would only react with **Z**.

*Experiment 2:* Oxide of **X** reacts with all metals but **not Y**.

- (a) Arrange the four metals **W**, **X**, **Y** and **Z** in order of descending reactivity.

.....[1]

- (b) James noted that **X** is a silvery metal and has a melting point of 1528 °C.

He added a sample of **X** to a solution of dilute hydrochloric acid. This reaction produces a colourless gas and a coloured solution.

- (i) Name the colourless gas.

.....[1]

- (ii) When aqueous sodium hydroxide was added into the solution, a dirty-green precipitate was formed.

Determine the identity of **X**.

.....[1]

- (iii) Hence, predict the identity of metal **Y**.

.....[1]

[Total: 4]

**A4** Alcohols can react with copper(II) oxide to form compounds called aldehydes.

Table 4.1 shows the aldehyde formed from the respective alcohol.

Alcohol	Structural formula of alcohol	Aldehyde	Structural formula of aldehyde
Ethanol	$\begin{array}{c} \text{H} \quad \text{H} \\   \quad   \\ \text{H} - \text{C} - \text{C} - \text{OH} \\   \quad   \\ \text{H} \quad \text{H} \end{array}$	Ethanal	$\begin{array}{c} \text{H} \quad \text{O} \\   \quad    \\ \text{H} - \text{C} - \text{C} - \text{H} \\   \\ \text{H} \end{array}$
Propanol	$\begin{array}{c} \text{H} \quad \text{H} \quad \text{H} \\   \quad   \quad   \\ \text{H} - \text{C} - \text{C} - \text{C} - \text{OH} \\   \quad   \quad   \\ \text{H} \quad \text{H} \quad \text{H} \end{array}$	Propanal	$\begin{array}{c} \text{H} \quad \text{H} \quad \text{O} \\   \quad   \quad    \\ \text{H} - \text{C} - \text{C} - \text{C} - \text{H} \\   \quad   \\ \text{H} \quad \text{H} \end{array}$
Butanol	$\begin{array}{c} \text{H} \quad \text{H} \quad \text{H} \quad \text{H} \\   \quad   \quad   \quad   \\ \text{H} - \text{C} - \text{C} - \text{C} - \text{C} - \text{OH} \\   \quad   \quad   \quad   \\ \text{H} \quad \text{H} \quad \text{H} \quad \text{H} \end{array}$	Butanal	$\begin{array}{c} \text{H} \quad \text{H} \quad \text{H} \quad \text{O} \\   \quad   \quad   \quad    \\ \text{H} - \text{C} - \text{C} - \text{C} - \text{C} - \text{H} \\   \quad   \quad   \\ \text{H} \quad \text{H} \quad \text{H} \end{array}$

**Table 4.1**

**(a)** Aldehydes are an example of a homologous series.

**(i)** Explain how the information in Table 4.1 show this.

.....  
 .....[1]

**(ii)** Predict three differences in physical property between ethanal and propanal.

.....  
 .....  
 .....  
 .....[2]

**(b)** A by-product from the reaction to form ethanal is water.

**(i)** Write a balanced chemical equation for the formation of ethanal.

.....[1]

**[Turn over**

(ii) A sample of the alcohol with a mass of 15 g was used to make ethanal.

Determine the percentage purity of the ethanol if 11 g of ethanal was formed from the reaction.

[3]

(c) A student describes aldehydes as isomers of alcohol.

Explain, with a relevant example, whether this is a correct statement.

.....  
.....  
.....  
.....  
.....

[2]

[Total: 9]

**A5** Carbon suboxide ( $\text{O}=\text{C}=\text{C}=\text{C}=\text{O}$ ),  $\text{C}_3\text{O}_2$  is a colourless compound discovered in 1873.

- (a) Predict the physical state of carbon suboxide at room conditions. Explain your answer in terms of bonding and structure.

.....  
 .....  
 .....  
 .....[2]

- (b) Draw a 'dot and cross' diagram to show the bonding in carbon suboxide, showing only outermost electrons.

[2]

- (c) Theoretically this compound can be polymerized to produce polymers that are rigid, which has great potential for molecular nanotechnology.

- (i) Name the type of polymerisation.

.....[1]

- (ii) Draw the structure of the polymer showing only 2 repeating units.

[2]

[Total: 7]

**[Turn over**

**A6** Magnesium and calcium occur naturally in the mineral dolomite,  $\text{MgCO}_3 \cdot \text{CaCO}_3$ , a mixture of insoluble carbonates.

Useful products like magnesium sulfate and calcium sulfate can be obtained indirectly by adding dilute hydrochloric acid and some other chemicals into dolomite.

Calcium sulfate is used in the production of cement board and magnesium sulfate is used as fireproofing fabrics.

A simplified reaction scheme of the process is shown in Fig. 6.1.

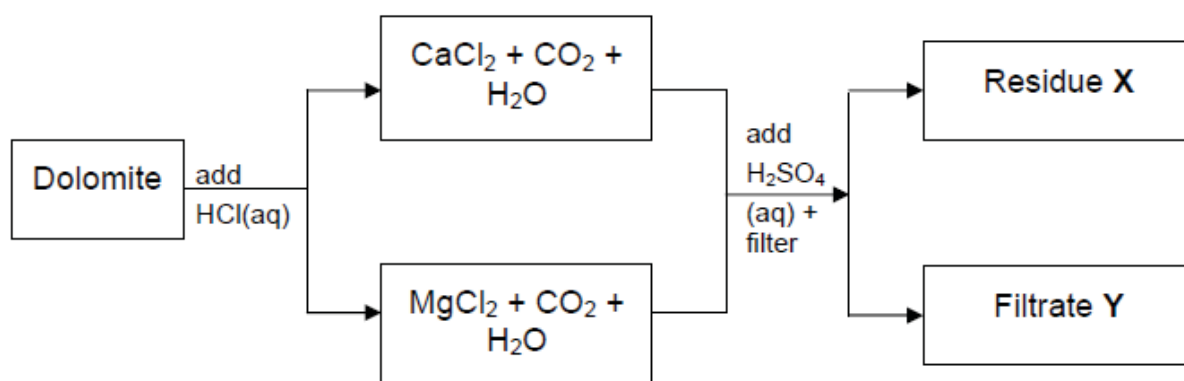

**Fig. 6.1**

**(a)** Identify residue **X** and filtrate **Y**.

residue X: .....

filtrate Y: .....[2]

**(b)** Explain why dolomite is added in excess to aqueous hydrochloric acid.

.....  
 .....[1]

**(c)** Describe the steps to obtain hydrated crystals from filtrate **Y**.

.....  
 .....  
 .....[2]

[Total: 5]

**A7** The reaction between ethene and steam is reversible as shown by the equation.

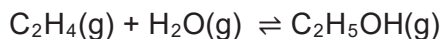

The energy profile diagram depicts the changes in energy levels as the forward reaction proceeds. [Grab your reader's attention with a great quote from the document or use this space to emphasize a key point. To place this text box anywhere on the page, just drag it.]

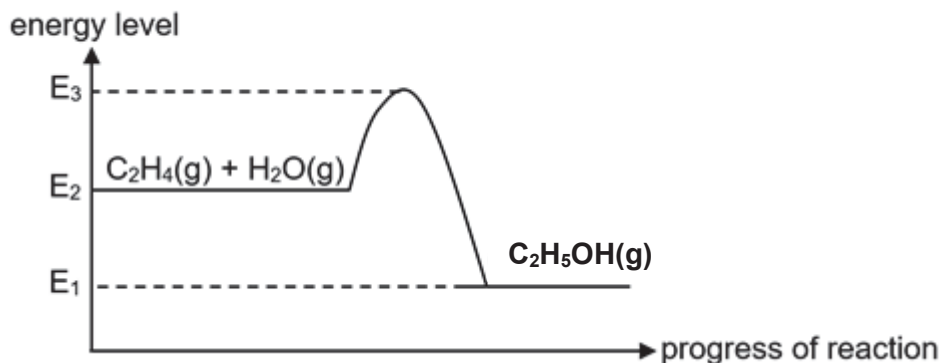

**(a)** What does each of the energy changes represent?

- (i)**  $E_2$   
 $E_1$  : .....
- (ii)**  $E_3 - E_1$   
 : .....
- (iii)**  $E_3 - E_2$   
 : .....[3]

**(b)** The table shows some bond energies, measured in kilojoules per mole.

bond	bond energy in kJ / mol
H - H	436
C - O	358
O - H	463

bond	bond energy in kJ / mol
C - C	348
C = C	612
C - H	412

- (i)** Using the information given, calculate the enthalpy heat change of the forward reaction.

[Turn over

- (ii) Explain, in terms of bond making and breaking, if the forward reaction results in any temperature change. [2]

.....

.....

.....

.....[3]

[Total: 8]

----- End of Section A -----

### Section B (30 marks)

Answer all **three** questions in this section in the spaces provided. The last question is in the form of an either/or and only one of the alternatives should be attempted.

- B8** The polycarbonates are polymers which have organic functional groups linked together by carbonate groups.

There are many polycarbonates which vary in properties depending on their molecular mass and structure. As the molecular mass increases, the polymer becomes more rigid. Further, the properties are changed by blending it with other polymers, for example, with ABS and polyesters such as PET.

Polycarbonates used in engineering are strong, tough materials, and some grades are optically transparent. Application include the making of cell phone frames, data storage and aircraft components.

Disposal of objects containing polycarbonate in landfills is an issue as it forms BPA and carbon dioxide at higher temperatures. BPA is non-biodegradable and can leach into water bodies from the landfills. In addition, it leaches more over time as it ages in landfills.

The polycarbonate can be manufactured by condensation polymerization between **bisphenol A** and **diphenyl carbonate**.

The production of diphenyl carbonate is a two-step process as shown below

1. Reaction of **methanol**, oxygen and carbon monoxide, in the presence of a copper salt such as copper(II) chloride, to form dimethyl carbonate. The copper salt is not used up and can be recycled for further reactions.

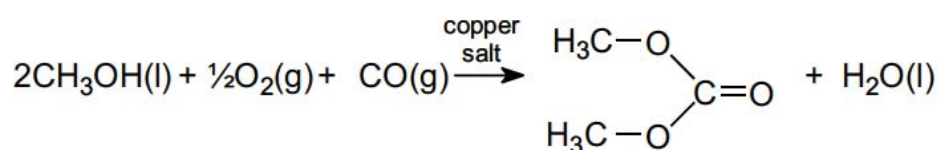

2. Dimethyl carbonate reacts with phenol to form diphenyl carbonate.

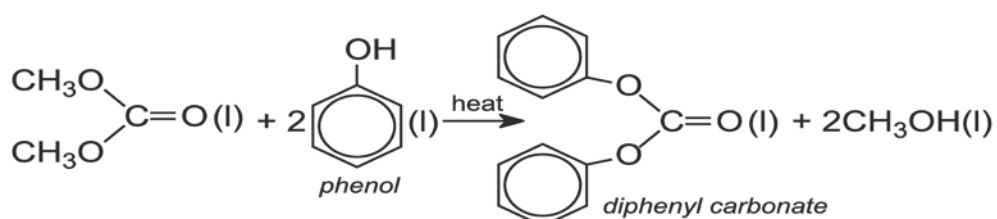

[Turn over

where  represents  $C_6H_x$

Finally, Bisphenol A and the diphenyl carbonate are heated together to form a molten mass of polymer:

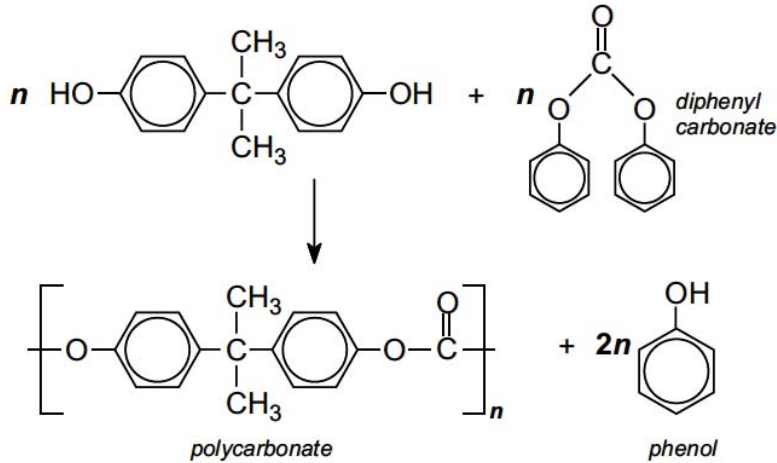

The phenol and excess reactants are removed by distillation under reduced pressure.

(a) Draw the structural formula of the linkage that is present in polycarbonates.

[1]

(b) Based on the information given, predict the adverse effects on the environment due to the disposal of polycarbonates.

.....  
 .....  
 .....  
 ..... [3]

- (c) (i) State the role of copper(II) chloride in the first reaction. Explain how you reach this conclusion.

.....  
.....  
..... [2]

- (ii) If the relative mass of phenol is 94, predict the value of x in  $\text{C}_6\text{H}_x$ .

- (iii) The relative mass of the polycarbonate ranges from 18 000 to 32 000. [1]

Find the minimum value of n for the polycarbonate and, hence, determine the minimum mass of phenol required for the formation of polycarbonates.

[3]

[Turn over

(d) Bisphenol A can also react with a dicarboxylic acid to form a polyester.

Draw the structural formula of the polyester formed.

The dicarboxylic acid can be represented by:

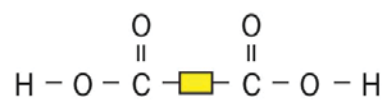

[2]

[Total: 12]

**B9** Diagram 9.1 shows the electrolysis of dilute magnesium chloride.

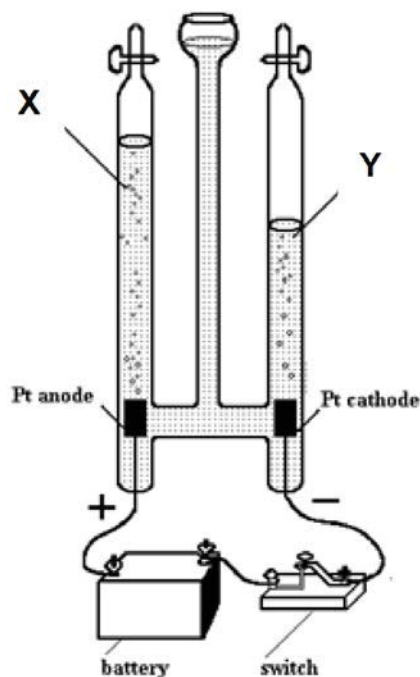

**Diagram 9.1**

**(a)** Write the balanced ionic equations, with state symbols, for the reactions at **X** and **Y**.

.....  
 .....[2]

**(b) (i)** Explain why the theoretical ratio of the volumes of gases collected at **X** and **Y** should be 1:2.

.....  
 .....  
 .....[2]

**(ii)** Knowing that the gas collected at **X** is much more soluble in water than that in **Y**, Explain how would the actual volume ratio compare to the one in theoretical?

.....  
 .....

**[Turn over**

.....[2]  
(c) A few drops of universal indicator is added to Y.

Determine and explain the observation at Y.

.....  
.....  
.....[2]

[Total: 8]

**Either**

**B10** Diesel obtained from crude oil is often called fossil diesel. Biodiesel can be made from many vegetable oils.

Tiny particles of solids are produced when the fuel does not burn completely. This increases the level of particulates (PM10) in the atmosphere. These particles are small enough to pass through the throat and nose and enter the lungs.

One research project compared the exhaust emissions when fossil diesel or biodiesel were used as fuels. Some of the relative amounts of these exhaust emissions are shown in Fig.10.1.

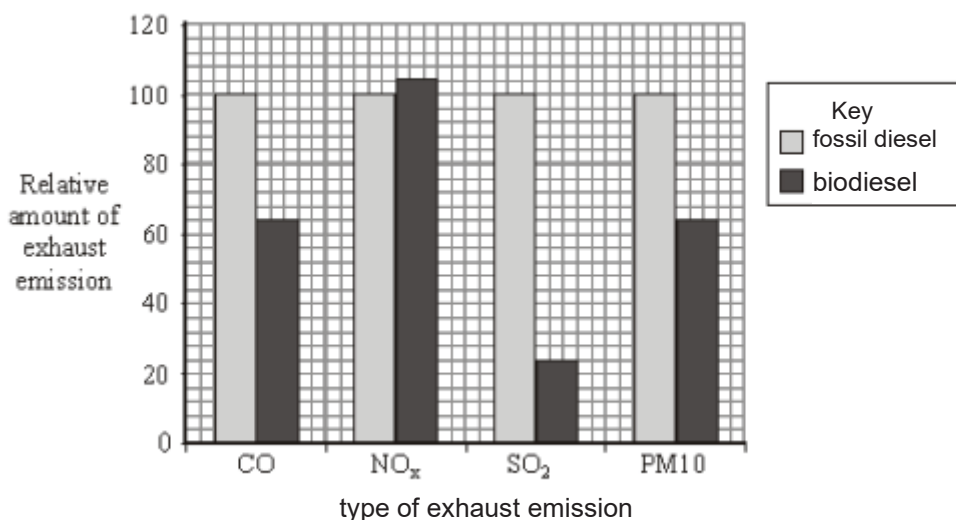

**Fig. 10.1**

**(a) (i)** Using the data given, compare the exhaust emission between fossil diesel and biodiesel.

.....

.....

.....

.....[2]

**[Turn over**

- (ii) Exhaust emissions from fossil diesel cause more harm to human health than those from biodiesel. Explain why.

.....

.....

.....

.....[2]

- (b) Some scientists suggest that biodiesel is **carbon neutral**. Explain why.

.....

.....

.....

.....[2]

- (c) Refrigerants are substances used to cool refrigerators and freezers. Until recently, many of the compounds used as refrigerants were chlorofluorocarbons (CFCs).

One such reaction with CFC<sub>3</sub> is shown below.



The Cl atom reacts with ozone in a two-step reaction.

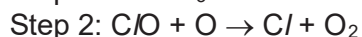
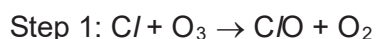

- (i) One molecule of CFC<sub>3</sub> can destroy thousands of ozone molecules. Explain why.

.....

.....

.....[2]

- (ii) Fig. 10.2 below shows the mass and amount of carbon, fluorine and chlorine atoms in one mole of a certain compound of CFCs found in the aerosol can of hairspray.

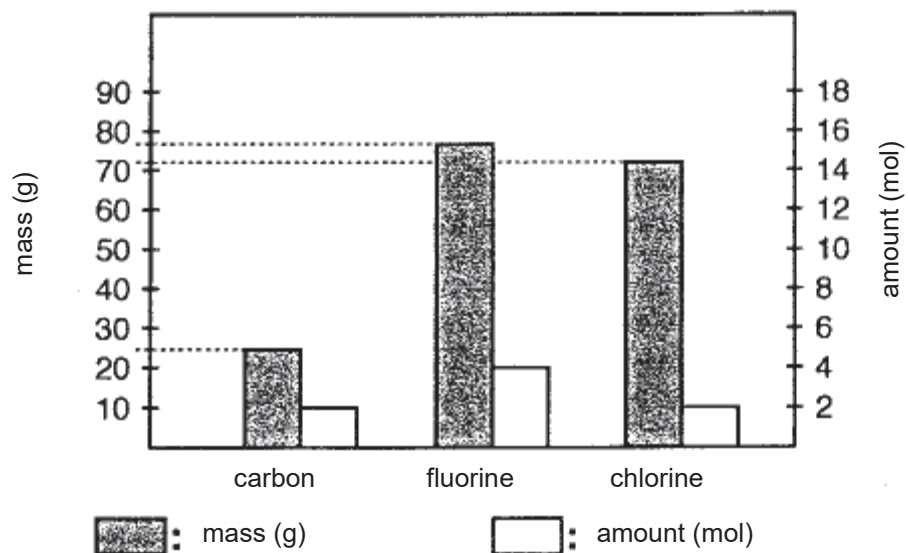

Fig. 10.2

Using the above information, determine the molecular formula of this CFCs compound.

[2]

[Total: 10]

[Turn over

Or

**B10** Zinc reacts with aqueous iodine to form zinc iodide. The following apparatus below was used to measure the rate of the reaction between zinc and aqueous iodine at 25 °C.

The mass of the zinc plate was measured every minute until the reaction was completed.

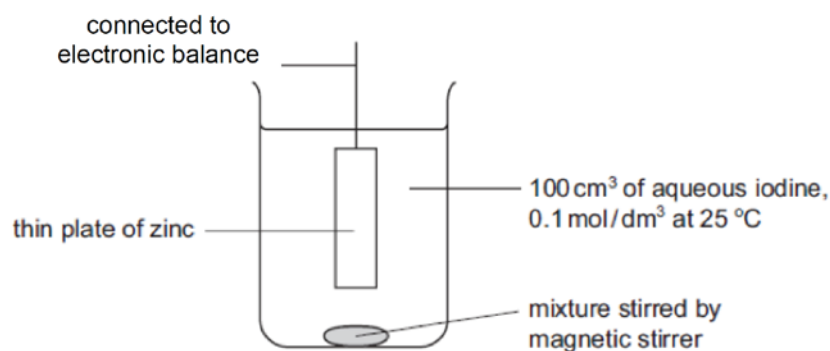

Graph 10.1 below shows the results obtained.

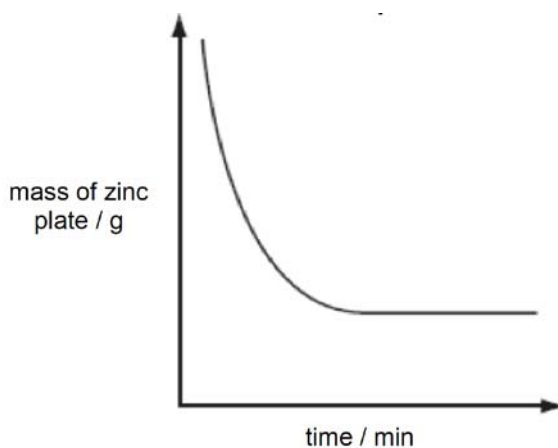

**Graph 10.1**

(a) Identify the reagent that was used in excess.

.....[1]

(b) (i) The experiment was repeated with 100 cm<sup>3</sup> of 0.05 mol/dm<sup>3</sup> of aqueous iodine and keeping all other conditions the same. On the same axes as **Graph 10.1** above, sketch the curve that would be obtained and label it 'Y'.

[1]

(ii) Explain the shape of the graph obtained in (b)(i).

.....  
.....  
.....  
.....[2]

(c) Explain, in terms of collisions between reacting particles, the effect on the speed of reaction if the experiment was repeated at 30 °C with all other conditions kept constant.

.....  
.....  
.....  
.....  
.....[3]

(d) Aqueous chlorine was bubbled into zinc iodide solution.

(i) Write the chemical equation for the reaction.

.....[1]

(ii) Explain, in terms of electron transfer, why this reaction is considered a redox reaction.

.....  
.....  
.....[2]

[Total: 10]

----- End of Section B -----

----- End of Paper -----

[Turn over



