

Visit

FREETESTPAPER.com

for more papers



Website: [freetestpaper.com](http://www.freetestpaper.com)



[Facebook.com/freetestpaper](https://www.facebook.com/freetestpaper)



[Twitter.com/freetestpaper](https://www.twitter.com/freetestpaper)

Paper 1: Multiple Choice (40 marks)

Shade your answers in the OAS sheet provided.

- 1 The following diagram shows a method to collect a sample of gas **P**.

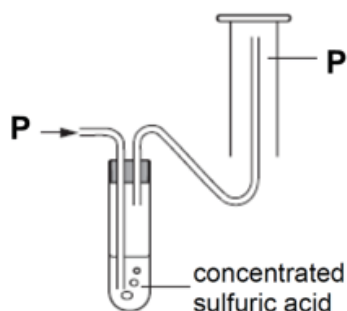

Which of the following statements is true about gas **P**?

- 1 **P** is alkaline.
- 2 **P** is soluble in water.
- 3 **P** is less dense than air.

- A** 1 only
- B** 1 and 3
- C** 2 and 3
- D** 3 only

- 2 The results of a paper chromatography experiment are shown.

X is an aqueous solution of a salt of a Group I element.

Y is an aqueous solution of a salt of a transition element.

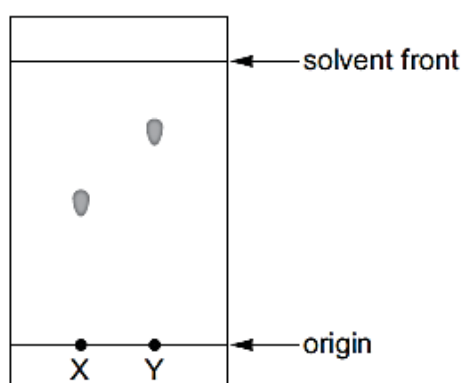

Which row is correct?

	larger R_f value	requires a locating agent
A	X	X
B	X	Y
C	Y	X
D	Y	Y

- 3 The apparatus shown is used to distil ethanol from a mixture of ethanol and water.

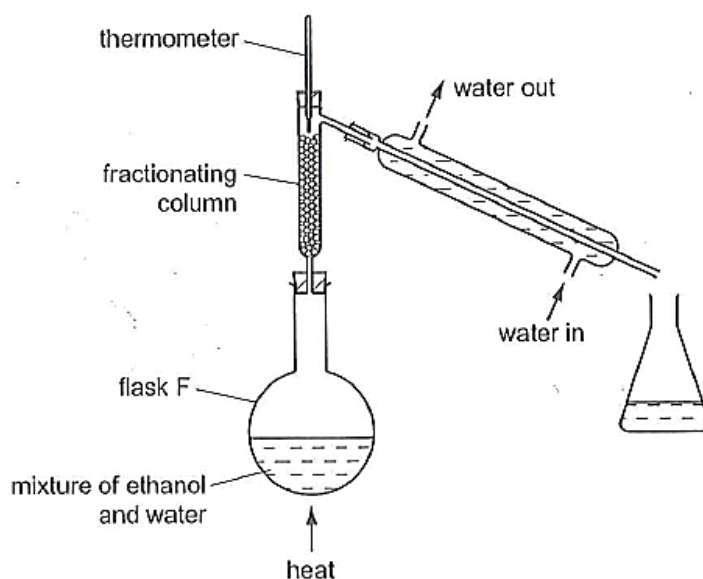

Which graph shows the change in concentration of ethanol in flask F over time?

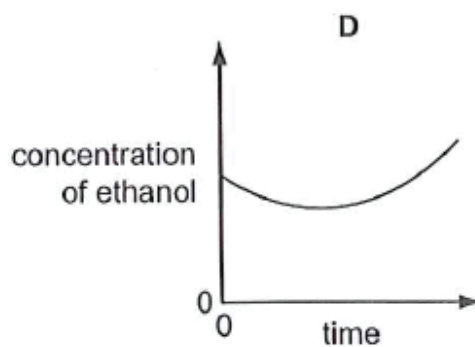
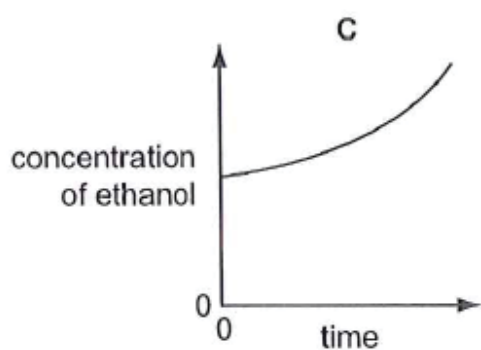
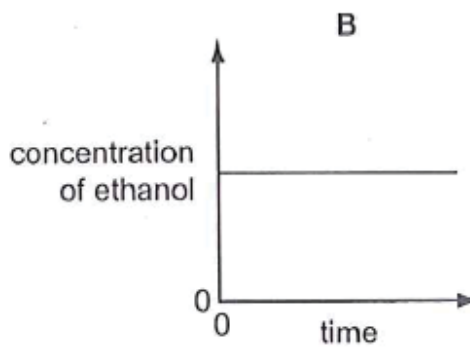
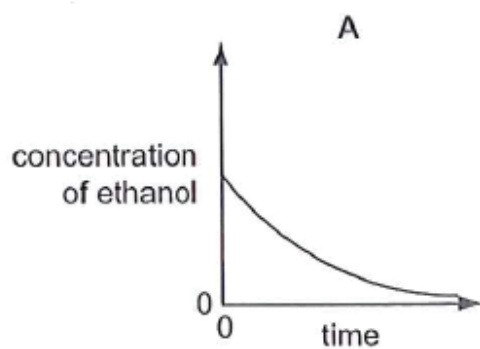

- 4 Which particle contains the same number of both neutrons and electrons?

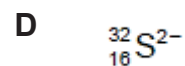
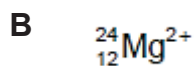
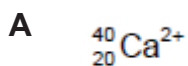

- 5 The graph shows the change in temperature when ice at $-20\text{ }^{\circ}\text{C}$ is heated to $120\text{ }^{\circ}\text{C}$.

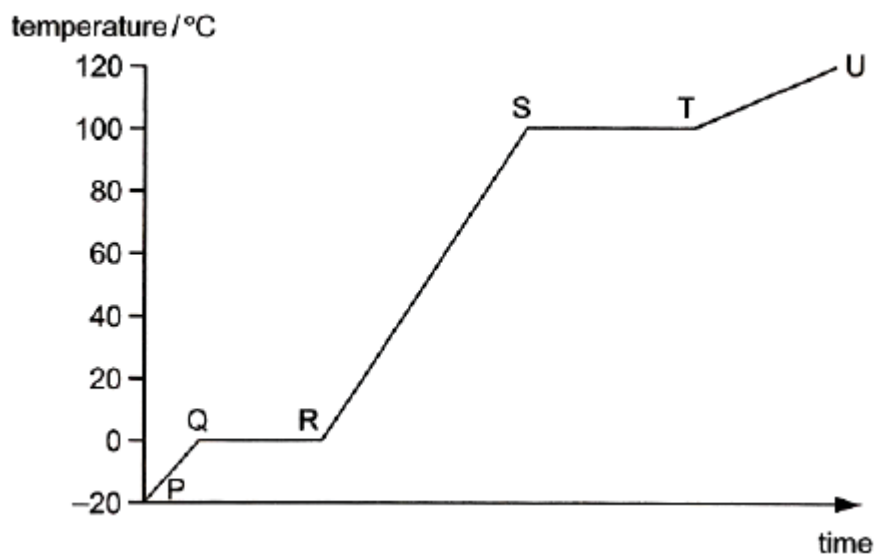

Which row shows the correct change taking place for the respective region in the graph?

	region	change
A	P to Q	average energy of particles decrease
B	Q to R	water is freezing
C	R to S	average energy of particles increase
D	S to T	particles come closer together

- 6 A new substance was discovered and a series of experiments were conducted on it.

Which observations confirms that the substance is a compound?

- A** Electrolysis of the molten substance forms two products.
- B** It dissolves in water.
- C** It melts over a range of temperatures.
- D** When heated in air, it forms one oxide only.

- 7 Which salt contains covalent bonds?

- A** ammonium chloride
- B** magnesium bromide
- C** potassium iodide
- D** sodium fluoride

8 Which diagram represents the structure of quartz, SiO_2 ?

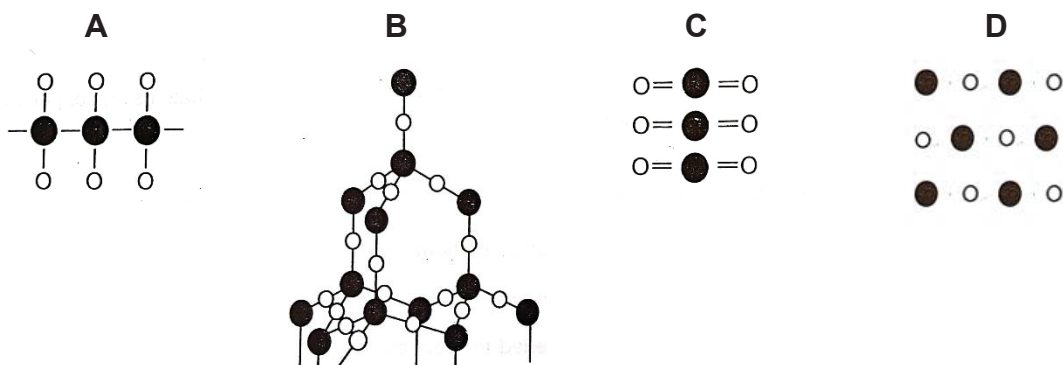

9 The diagram shows part of the Periodic Table.

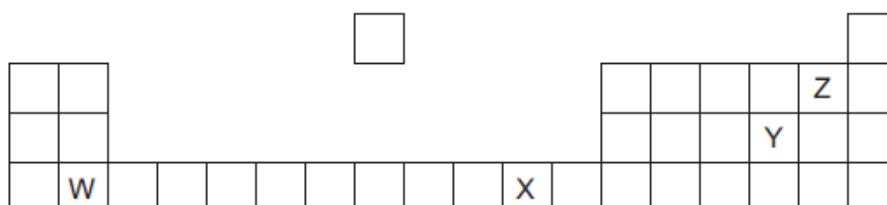

Which row correctly shows the type of bonding in the compound formed between the elements?

	covalent	ionic
A	W and Z	X and Y
B	W and Y	Y and Z
C	X and Y	W and Y
D	Y and Z	X and Z

10 Which pair of substances conduct electricity due to the presence of delocalised electrons?

- A** copper metal and nitric acid
- B** graphite and copper metal
- C** graphite and molten potassium bromide
- D** nitric acid and molten potassium bromide

11 Which sample contains the most atoms?

- A** 0.50 mol of water
- B** 1.00 mol of carbon dioxide
- C** 1.00 mol of methane
- D** 2.00 mol of hydrogen chloride

- 12 5.00 g of a metal oxide, MO_2 , is reduced to form 3.16 g of metal **M**.

What is the identity of **M**?

- A lead ($A_r = 207$)
 B manganese ($A_r = 55$)
 C tin ($A_r = 119$)
 D titanium ($A_r = 48$)
- 13 A hydrocarbon is a compound made up of carbon and hydrogen atoms only.

In an experiment, 1 cm^3 of a gaseous hydrocarbon, **Q**, required 4 cm^3 of oxygen for complete combustion to give 3 cm^3 of carbon dioxide. All gas volumes are measured at room temperature and pressure.

Which formula represents the hydrocarbon, **Q**?

- A C_2H_2 B C_2H_4 C C_3H_4 D C_3H_8
- 14 Ammonium nitrate, NH_4NO_3 , decomposes to form dinitrogen oxide and water upon heating as shown in the equation below.



When an impure sample of ammonium nitrate is heated, 27 g of water is formed.

Which expression shows the mass of ammonium nitrate in the impure sample?

- A $66 \times \frac{27}{36} \text{ g}$ B $80 \times \frac{27}{36} \text{ g}$ C $80 \times \frac{27}{18} \text{ g}$ D $80 \times \frac{9}{36} \text{ g}$
- 15 In which circuit does the bulb light up?

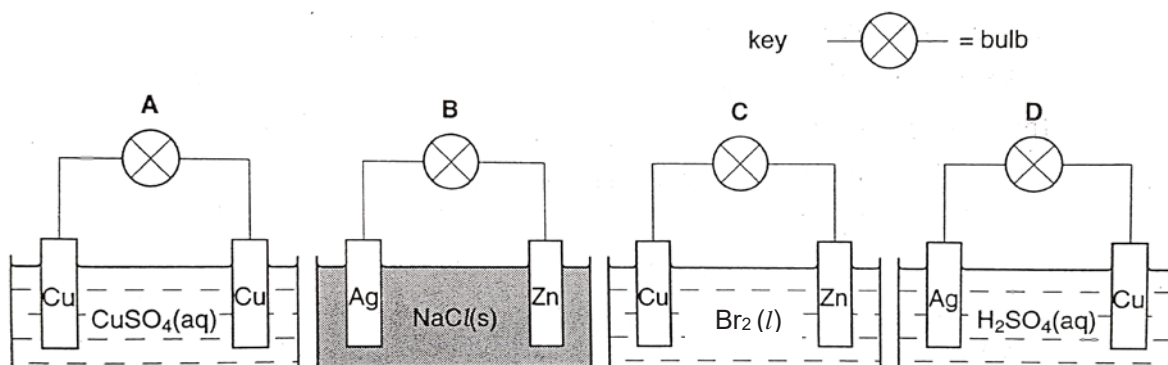

- 16 A piece of blue litmus paper was soaked in concentrated aqueous sodium chloride and supported on a glass slide. The paper was connected to an electrical supply as shown in the diagram.

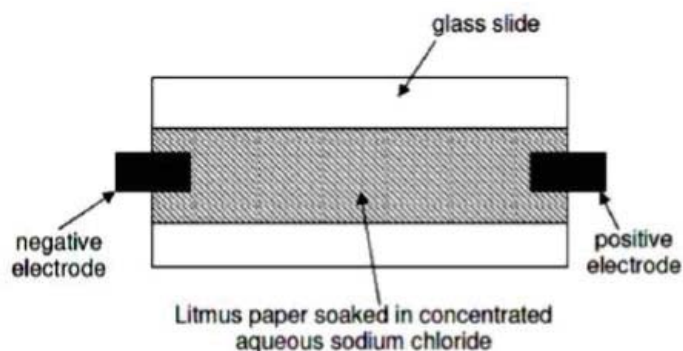

Which of the following shows the correct observations near each electrode after some time?

	negative electrode	positive electrode
A	remain blue	turn red and then bleached
B	remain blue	remain blue
C	turn red	turn red and then bleached
D	turn red and then bleached	remain blue

- 17 Electrolysis is used to plate a metal statue with silver. Which row correctly shows the electrolyte used and the electrode that the statue should be connected to?

	electrolyte	statue
A	silver chloride	cathode
B	silver nitrate	cathode
C	silver chloride	anode
D	silver nitrate	anode

- 18 Three different processes using electrolysis with inert electrodes are listed.

- 1 electrolysis of concentrated aqueous sodium chloride
- 2 electrolysis of dilute sulfuric acid
- 3 electrolysis of dilute copper(II) chloride

Which processes form a gas at the cathode?

- A** 1 and 2 **B** 2 only **C** 2 and 3 **D** 3 only

- 19 The diagram below shows the set-up of an electric cell using electrodes of copper and metal T.

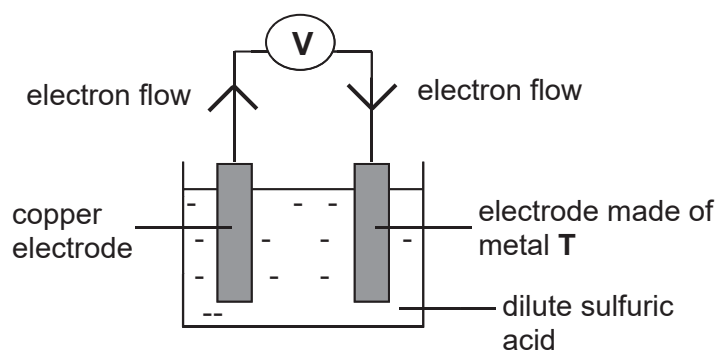

Which statement is correct?

- A Copper is less reactive than metal T.
 - B Effervescence will be observed at metal T.
 - C Oxidation occurs at metal T.
 - D The mass of copper electrode will increase over time.
- 20 Four chemical equations of processes are listed.

- 1 $\text{H}_2\text{O} (l) \rightarrow \text{H}_2\text{O} (g)$
- 2 $6 \text{H}_2\text{O} (g) + 6 \text{CO}_2 (g) \rightarrow \text{C}_6\text{H}_{12}\text{O}_6 (g) + 6 \text{O}_2 (g)$
- 3 $2 \text{H}_2 (g) + \text{O}_2 (g) \rightarrow 2 \text{H}_2\text{O} (g)$
- 4 $\text{C}_6\text{H}_{12}\text{O}_6 (g) + 6 \text{O}_2 (g) \rightarrow 6 \text{H}_2\text{O} (g) + 6 \text{CO}_2 (g)$

Which processes are exothermic?

- A 1 and 2
 - B 1 and 3
 - C 2 and 4
 - D 3 and 4
- 21 A compound reacts with oxygen. This reaction has a positive enthalpy change of reaction, ΔH .

What statement is correct?

- A The compound can be used as a fuel.
- B During the reaction, temperature of surrounding increases.
- C In the reaction with oxygen, the energy taken in to break bonds is greater than the energy released when bonds are made.
- D In the reaction with oxygen, the number of bonds formed is greater than the number of bonds broken.

- 22 Ethyne (C_2H_2) reacts with hydrogen to form ethane (C_2H_6) as shown in the equation below.

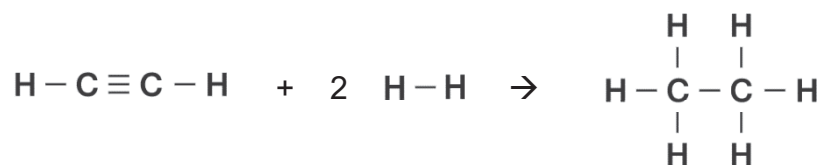

The average energies of the bonds in the substances involved are shown in the table below.

bond	bond energies (kJ/mol)
C – H	413
C – C	347
C ≡ C	839
H – H	432

What is the enthalpy change for this reaction?

- A** +51 kJ/mol **B** –176 kJ/mol **C** –296 kJ/mol **D** –726 kJ/mol
- 23 The table shows the energy released by the complete combustion of some compounds.

compound	formula	M_r	ΔH in kJ/mol
benzene	C_6H_6	78	– 3270
heptane	C_7H_{18}	100	– 4800
octane	C_8H_{18}	114	– 5510
propane	C_3H_8	44	– 2210

Which compound releases the least energy when 1 g of the compound is completely burnt?

- A** benzene
B heptane
C octane
D propane

24 In which reaction is the pressure **least** likely to affect the rate of reaction?

- A $\text{C (s)} + \text{CO}_2 \text{ (g)} \rightarrow 2 \text{CO (g)}$
 B $2 \text{SO}_2 \text{ (g)} + \text{O}_2 \text{ (g)} \rightarrow 2 \text{SO}_3 \text{ (g)}$
 C $\text{N}_2 \text{ (g)} + 3 \text{H}_2 \text{ (g)} \rightarrow 2 \text{NH}_3 \text{ (g)}$
 D $\text{NaOH (aq)} + \text{HCl (aq)} \rightarrow \text{NaCl (aq)} + \text{H}_2\text{O (l)}$

25 Dilute hydrochloric acid was reacted with 1.2 g of magnesium ribbon at room temperature in two experiments, experiment 1 and experiment 2.

In experiment 1, 100 cm³ of 1 mol/dm³ of hydrochloric acid was used.

In experiment 2, 50 cm³ of 2 mol/dm³ of hydrochloric acid was used.

The volume of hydrogen given off was plotted against time.

Which graph is correct?

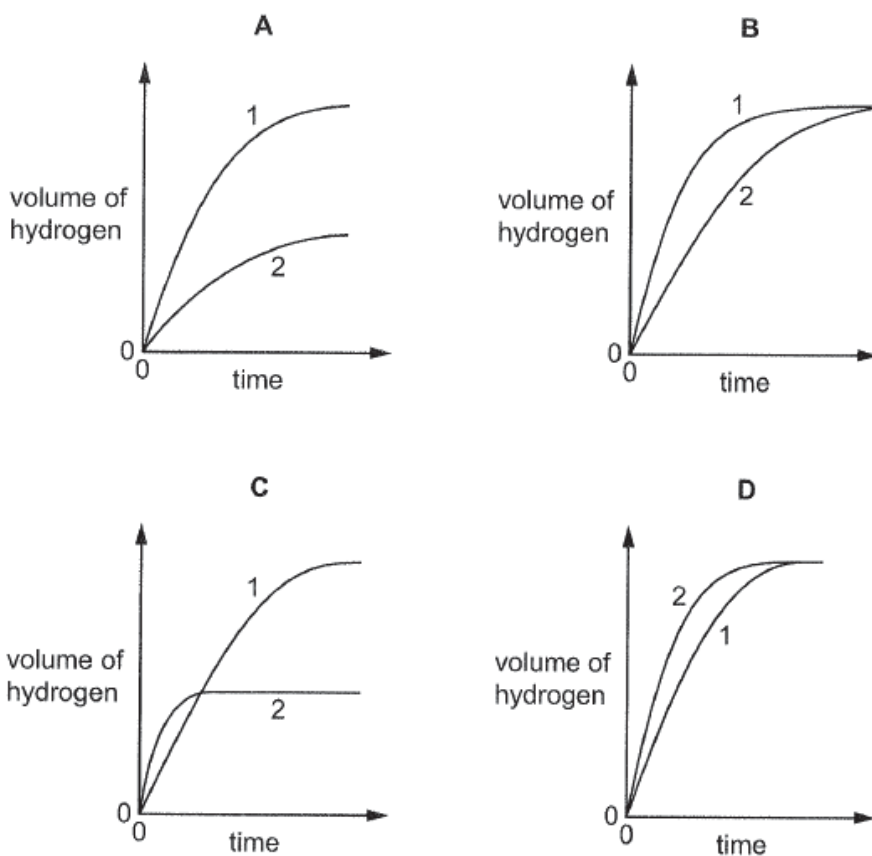

26 Equations for reactions of iron and iron compounds are shown.



How many of these are redox reactions?

- A** 1 **B** 2 **C** 3 **D** 4

27 Hydrogen peroxide reacts with aqueous potassium iodide and dilute sulfuric acid as shown in the chemical equation.

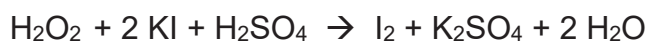

Which statement is correct?

- A** Brown potassium iodide is decolourised in the reaction.
B Iodide ions are oxidised.
C Hydrogen peroxide is a reducing agent.
D Oxidation state of sulfur changes from +6 to +4.

28 A dilute solution of a strong dibasic acid, H_2X , contains both water molecules and the ions H^+ and X^{2-} .

Which statement is correct?

- A** The solution contains a high concentration of H_2X molecules.
B The solution contains OH^- ions.
C There are less H^+ ions than X^{2-} ions in the solution.
D There are less water molecules than H^+ ions.

29 The oxides of three elements, **T**, **U** and **V**, are added to water.

	oxide of T	oxide of U	oxide of V
water added	dissolved to form a solution of pH 2	insoluble	dissolved to form a solution of pH 13

The oxide of **U** is white in colour.

What is **T**, **U** and **V**?

	T	U	V
A	calcium	aluminium	sulfur
B	calcium	copper	sulfur
C	sulfur	aluminium	calcium
D	sulfur	copper	calcium

30 In an experiment, 1 mol of powdered copper and 1 mol of powdered zinc are placed in a flask. 2 mol of hydrochloric acid is then added to the flask.

The flask is left until all the reactions, if any, are complete.

Which diagram shows the result of the experiment?

A

colourless neutral solution

1 mol of copper

B

blue neutral solution

0.5 mol of copper + 0.5 mol of zinc

C

blue neutral solution

1 mol of zinc

D

colourless acidic solution

1 mol of copper

31 The following reactions are carried out.

reaction	result
ethanoic acid is added to ammonium carbonate	gas E is given off
ammonium ethanoate is warmed with solution F	pungent gas G is given off that turns moist red litmus paper blue

What are **E**, **F** and **G**?

	E	F	G
A	ammonia	ethanoic acid	carbon dioxide
B	ammonia	sodium hydroxide	ammonia
C	carbon dioxide	ethanoic acid	carbon dioxide
D	carbon dioxide	sodium hydroxide	ammonia

32 Which reactants could be used safely to prepare sodium nitrate?

- A** aqueous sodium hydroxide and dilute nitric acid
- B** aqueous sodium sulfate and aqueous potassium nitrate
- C** sodium and aqueous potassium nitrate
- D** sodium and dilute nitric acid

33 Four statements about different elements are given.

- 1 cuts easily with a knife
- 2 constituent of brass
- 3 catalyst in the Haber process
- 4 burns in oxygen with a bright white light

Which statement is correct for each element?

	Fe	Mg	Na	Zn
A	1	3	2	4
B	2	4	1	3
C	3	4	1	2
D	3	2	1	4

- 34 Which statement about the groups in the Periodic Table is correct?
- A All groups contain both metals and non-metals.
 B Atoms of elements in the same group have the same number of electrons.
 C In Group I, reactivity decreases with increasing proton number.
 D In Group VII, the melting point increases with increasing proton number.
- 35 An aqueous solution of a compound, **T**, undergoes the following reactions.

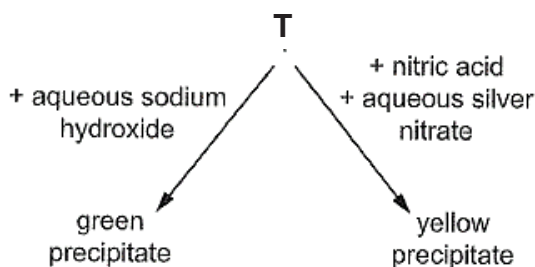

What is **T**?

- A iron(II) carbonate
 B iron(II) iodide
 C iron(III) carbonate
 D iron(III) iodide
- 36 The table shows four metals and some of their reactions.

metal	action of heat on carbonate	reaction with steam	reaction with dilute acid
G	decompose	no reaction	no reaction
H	no reaction	hydrogen evolved	hydrogen evolved
I	decompose	no reaction	hydrogen evolved
J	decompose	hydrogen evolved	hydrogen evolved

What is the correct order of reactivity of these four metals?

	most reactive		→	least reactive	
A	H	J		I	G
B	H	I		J	G
C	I	J		G	H
D	I	H		G	J

37 The experiment below investigates the rusting of iron nails.

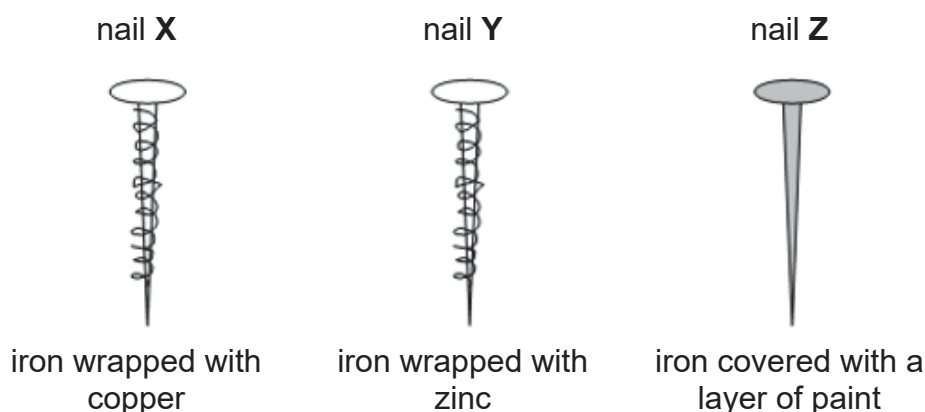

Which nails will rust?

- A** None **B** X only **C** X and Y **D** Y only

38 Which substance removes impurities from iron ore in the blast furnace?

- A** carbon
B limestone
C sand
D slag

39 Catalytic converters are used in the removal of harmful pollutants from exhaust gases. Which equations do **not** occur in a catalytic converter?

- A** $2 \text{CO} + \text{O}_2 \rightarrow \text{CO}_2$
B $2 \text{C}_8\text{H}_{18} + 25 \text{O}_2 \rightarrow 16 \text{CO}_2 + 18 \text{H}_2\text{O}$
C $2 \text{NO} + 2 \text{CO} \rightarrow \text{N}_2 + 2 \text{CO}_2$
D $\text{N}_2 + \text{O}_2 \rightarrow 2 \text{NO}$

40 Methane, chlorofluorocarbons(CFCs) and carbon dioxide are all gases which affect the atmosphere and the environment.

In what way do these gases affect the environment?

	methane	chlorofluorocarbons (CFCs)	carbon dioxide
A	acid rain	global warming	photochemical smog
B	depletion of ozone layer	photochemical smog	global warming
C	global warming	depletion of ozone layer	global warming
D	global warming	depletion of ozone layer	acid rain

Section A

Answer **all** questions in the spaces provided.
The total mark for this section is 50.

A1 Use the list of substances to answer the questions.

ammonia

graphite

nitric acid

zinc

calcium

copper

(a) Which substance exists as giant molecular structure?

..... [1]

(b) Which substance forms an amphoteric oxide?

..... [1]

(c) Which substance forms a coloured compound?

..... [1]

(d) (i) Which two compounds can be reacted together to form an ammonium salt?

..... [1]

(ii) Give the formula of the salt in **(d)(i)**.

..... [1]

[Total: 5 marks]

- A2** The Contact Process is an industrial process for producing sulfuric acid. During this process, sulfur dioxide is converted to sulfur trioxide, in the presence of oxygen and vanadium(V) oxide.

The equations show the stages in the process of producing sulfur trioxide.

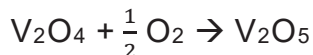

- (a) Write an overall equation for the process.

..... [1]

- (b) Identify the catalyst in the process.

Explain your answer.

.....

 [2]

- (c) Without the catalyst the reaction between sulfur dioxide and oxygen is very slow.

Explain, in terms of collision and energy, how the use of a catalyst increases the rate of this reaction.

.....

 [2]

- (d) Explain why it is important that in the process, sulfur dioxide are not released into the atmosphere.

.....
 [1]

[Total: 6 marks]

A3 An experiment was set up to determine the rate of diffusion of gases.

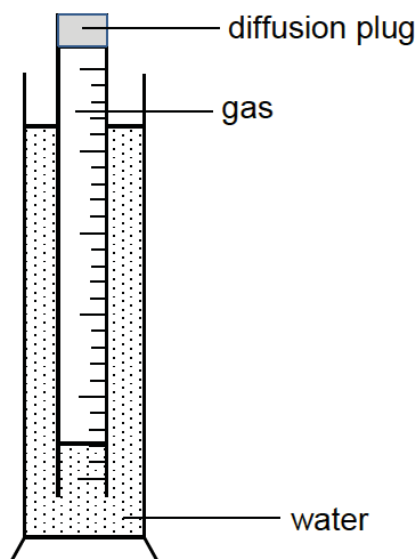

The time taken for 100 cm^3 of some gases at room temperature and pressure to diffuse from this apparatus are recorded in the following table.

gas	CO	Cl_2	CH_4	N_2	O_2
time / s	132	211	100	?	141

(a) Which gas diffuses the fastest?

Explain your reasoning.

.....

[2]

(b) Suggest the time that nitrogen would take to diffuse.

.....

[1]

(c) When conducting this experiment, the student makes this statement:

‘The temperature of this experiment must be kept constant’

Do you agree with the student?

Explain your reasoning.

.....

[2]

- (d) Suggest why this apparatus is unsuitable for finding the rate of diffusion of ammonia gas?

..... [1]

[Total: 6 marks]

A4 Magnesium is best known for burning with a characteristic brilliant white light. The metal was first produced by Sir Humphry Davy in 1808 by the electrolysis of a molten mixture of magnesia (MgO) and a little amount of mercury oxide. Inert electrodes were used during the electrolysis.

- (a) (i) Davy obtained magnesium at the cathode.

Write an ionic half-equation for the reaction at the cathode.

..... [1]

- (ii) Name the product that was obtained at the anode.

Write an ionic half-equation for the reaction at the anode.

.....
 [2]

- (iii) Describe a simple test that would confirm the identity of the product at the anode.

Include the result of the test in your answer.

.....
 [2]

- (b) Suggest why mercury oxide was added to magnesia.

.....
 [1]

- (c) Table 4.1 below lists the natural abundances for the three stable isotopes of magnesium.

Table 4.1

isotope	^{24}Mg	^{25}Mg	^{26}Mg
natural abundance (%)	78.99	10.00	

- (i) Explain what is meant by the term *isotope*.

.....

..... [1]

- (ii) Complete Table 4.1 with the natural abundance of ^{26}Mg . [1]

- (iii) Using the values in Table 4.1, calculate the average relative mass for an atom of magnesium.

[2]

[Total: 10 marks]

A5 In the Haber Process, the percentage of ammonia present at equilibrium at different temperatures and pressures is shown in the table below.

pressure /atm	ammonia present at equilibrium (%)				
	temperature / °C				
	100	200	300	400	500
10	88.2	50.7	14.7	3.9	1.2
25	91.7	63.6	27.4	8.7	2.9
50	94.5	74.0	39.5	15.3	5.6
100	96.7	81.7	52.5	25.2	10.6
200	98.4	89.0	66.7	38.8	18.3
400	99.4	94.6	79.7	55.4	31.9
1000	99.9	98.3	92.6	79.8	57.5

(a) From the table, deduce how the percentage of ammonia present at equilibrium is affected by

(i) increasing temperature,

..... [1]

(ii) and increasing pressure.

..... [1]

(b) From the table, identify the operating pressure and temperature which gives maximum yield of ammonia.

..... [1]

(c) Explain why the conditions in part (b) is not commercially used.

.....

 [2]

(d) Ammonia is used to manufacture nitric acid by a two-stage process.

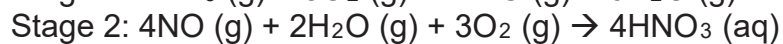
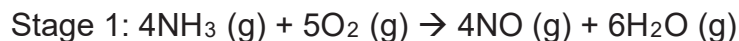

(i) Calculate the maximum mass of nitric acid which can be made from 965 dm^3 of ammonia at room temperature and pressure.

[2]

(ii) Stage 1 is an exothermic process.

Use ideas about bond breaking and bond making to explain why this reaction is exothermic.

.....

[2]

(iii) Hence, draw an energy profile diagram for the reaction in stage 1.

Your diagram should include labels for the reaction enthalpy change and activation energy.

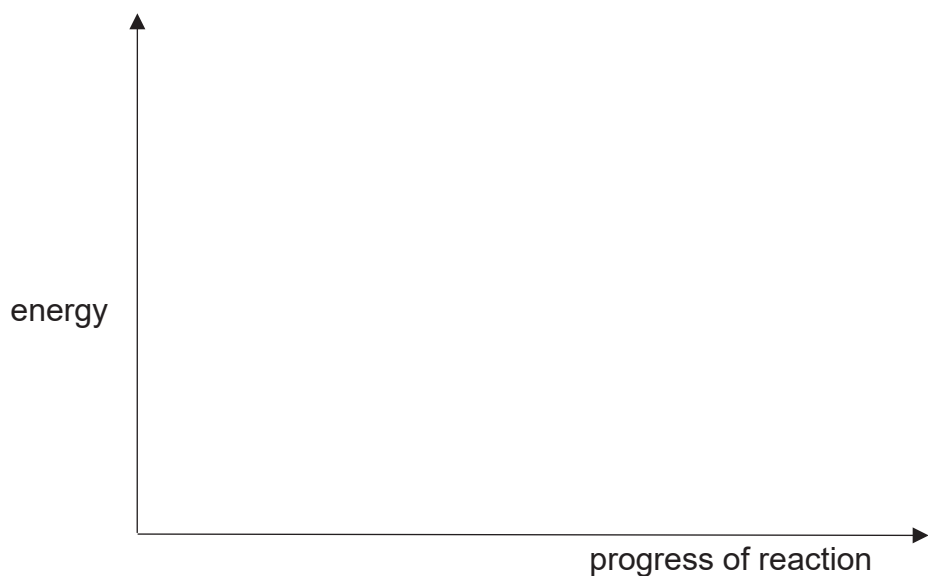

[2]

[Total: 11 marks]

A6 The flow chart shows some reactions of solid **E** and dilute nitric acid.

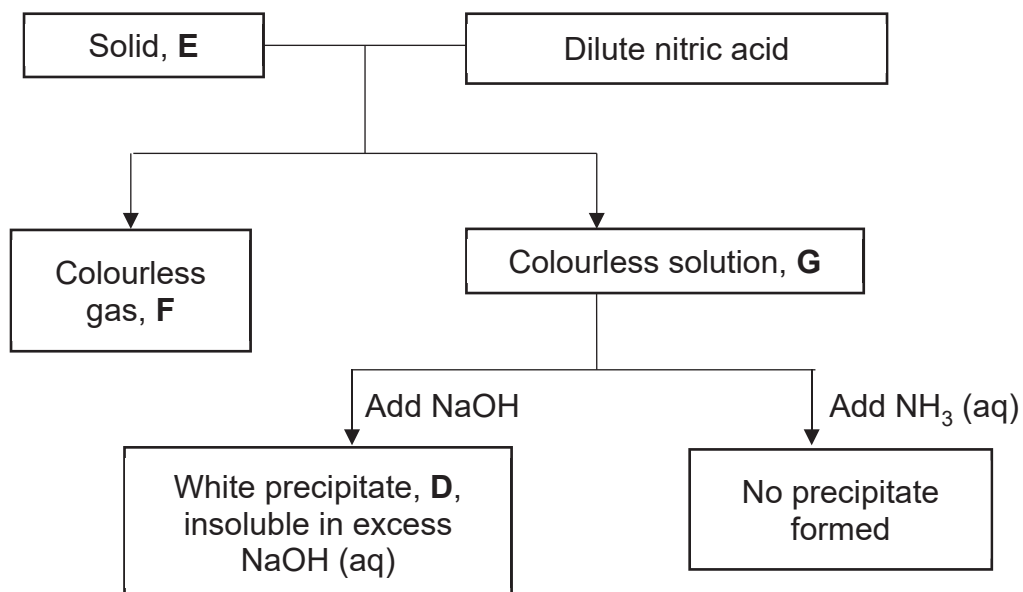

- (a) Analysis of a sample gas **F** showed that it contained 0.92 g of carbon and 2.43 g of oxygen.

Determine the empirical formula of gas **F**.

[2]

- (b) Name the following:

(i) precipitate **D** [1]

(ii) solid **E** [1]

(iii) solution **G** [1]

- (c) Write the ionic equation for the formation of white precipitate **D** when sodium hydroxide was added to solution **G**.

..... [1]

- (d) List the steps required to recover the pure and dry compound in solution **G**.

.....
.....
.....
..... [2]

[Total: 8 marks]

A7 Phosphane, PH_3 , is highly poisonous and used in the electronics industry.

- (a) Draw a dot-and-cross diagram to show the structure of phosphane.

Show the outer shell electrons only.

[2]

- (b) With reference to its bonding and structure, explain the expected state of phosphane at room temperature and pressure.

.....
.....
..... [2]

[Total: 4 marks]

Section B

Answer all **three** questions in this section.

The last question is in the form of an either/or and only one of the alternatives should be attempted.

B8 Read the information about the elements in Group VII of the Periodic Table.

Electron Affinity of Halogen

The ease of a non-metal atom gaining an electron can be determined from electron affinity. When an electron is added to an atom, the electron releases energy as it moves closer to the nucleus. Therefore, the enthalpy change for the addition of an electron to an atom is exothermic. If the electron added to the valence shell is less strongly attracted to the nucleus, it loses lesser amount of energy as it comes under the control of the nucleus.

The first electron affinity is the enthalpy change when one mole of gaseous atoms acquires one mole of electrons to form one mole of gaseous singly-charged anions. The reaction can be described by the equation below:

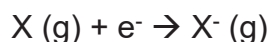

The table below shows a list of first electron affinity of Group VII non-metals.

halogen	first electron affinity/ kJ/mol
chlorine	-364
bromine	-342
iodine	-295

Thermal Stability of Hydrogen Halide

Hydrogen halides are diatomic compounds with the formula, HX, where X is one of the halogens, fluorine, chlorine, bromine, iodine or astatine. They are colourless gases at room temperature and pressure.

Thermal stability of a hydrogen halide is defined as how stable the hydrogen halide is when exposed to strong heating.

The table below shows the hydrogen halide bond, the bond length as well as its bond energy.

bond	bond length/ nm	bond energy/ kJ/mol
H – F	0.092	614
H – Cl	0.128	431
H – Br	0.141	346
H – I	0.160	299

- (a) What is the general trend between the first electron affinity and the position of the halogens in Group VII?

..... [1]

- (b) Based on the electron affinity, a student proposes that chlorine is a stronger oxidising agent than bromine.

Do you agree? Explain your reasoning.

.....

.....

..... [2]

- (c) The table shows the atomic radius of halogen.

halogen	atomic radius/ nm
F	0.072
Cl	0.099
Br	0.114
I	0.133

Based on the atomic radius of the halogens, explain how it affects the thermal stability of the hydrogen halides.

.....

.....

..... [2]

- (d) Hydrogen halides dissolve in water to form hydrohalic acids. They dissociate in water to form hydrogen ions and halide ions.

A student made the following comment,

'The strength of hydrohalic acids increases down the group, with hydrofluoric acid being the weakest acid.'

Do you agree with the student? Explain your reasoning.

.....

.....

.....

..... [3]

- B9** In an experiment, hydrogen gas was passed over equal masses of three heated metal oxides in identical porcelain boats as shown in the diagram.

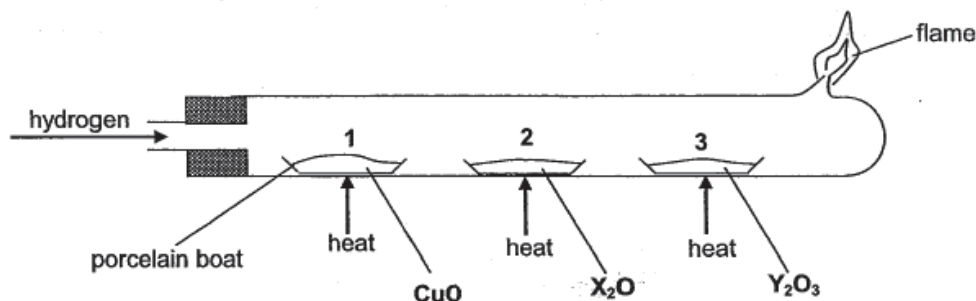

The porcelain boats were weighed 5 minutes into the experiment. After weighing, the experiment was allowed to continue for another 30 minutes where no further changes were observed. At the end of the experiment, the heat source was turned off. However, the hydrogen gas is kept flowing until the tube has cooled down.

The table shows some data from this experiment.

	at the start of experiment	5 minutes into the experiment	at the end of experiment
mass of empty porcelain boat/ g	16.35	-	16.35
mass of porcelain boat 1 and its content/ g	22.35	21.15	20.15
mass of porcelain boat 2 and its content/ g	22.35	22.35	22.35
mass of porcelain boat 3 and its content/ g	22.35	21.20	20.55

- (a) What would you expect to see happen in porcelain boat 1.

Explain with the aid of a balanced equation for the reaction that had occurred.

.....

[2]

- (b) (i) Put the three metals, Cu, **X**, and **Y**, in the order of their reactivity, starting with the most reactive.

..... [1]

- (ii) With reference to the data given, explain how you reach the conclusion in **(b)(i)**.

.....

.....

.....

.....

..... [2]

- (c) (i) Use the data given to calculate the mass of oxygen in Y_2O_3 in porcelain boat **3**.

[1]

- (ii) Hence, calculate the relative atomic mass of **Y**. From your result, identify **Y**.

[2]

- (d) (i) X_2O has a relatively high melting point.

Explain why X_2O has a high melting point. Refer to the structure and bonding of X_2O .

.....
.....
.....

[2]

- (ii) Given that X is found in the same period as copper, draw a dot-and-cross diagram to show the bonding of X_2O .

Show the outer shell electrons only.

[2]

[Total: 12 marks]

EITHER

- B10** Zinc is a metal resistant to corrosion and can be easily applied to other metals. Much of it is used to protect iron and steel products from corrosion. There are two methods of extracting zinc from sphalerite, an ore containing zinc sulfide.

Extraction Process 1

Sphalerite is first heated to produce zinc oxide.

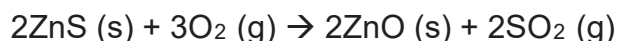

The zinc oxide is then heated in a blast furnace with coke. Hot air is blown into the blast furnace.

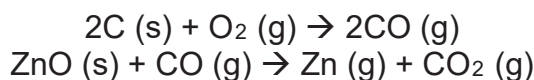

Zinc vapour and other waste gases are removed at the top of the furnace.

Extraction Process 2

The modern processes use electrolysis of aqueous solutions of very pure zinc sulfate. The first step in the process is the same as the first step in Extraction Process 1.

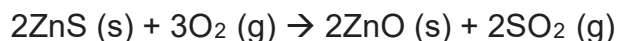

The sulfur dioxide formed in the first step is collected and used to produce sulfuric acid, which is then used in the second step to produce zinc sulfate solution.

The third step involves the electrolysis of zinc sulfate solution using aluminium electrodes, where zinc ions are preferentially discharged.

- (a) The equation in the first step of both extraction processes to produce zinc oxide is a redox reaction.

Use ideas about oxidation state to explain your answers.

.....

.....

.....

[2]

- (b) As compared to Extraction Process 1, Extraction Process 2 helps to reduce the environmental impact.

Explain why.

.....

.....

.....

[2]

.....

- (c) Write a balanced equation with state symbols, for the reaction between zinc oxide and sulfuric acid to produce zinc sulfate in the second step of **Extraction Process 2**.

.....

[2]

- (d) In **Extraction Process 2**, the process of obtaining zinc sulfate for electrolysis is shown in the diagram below.

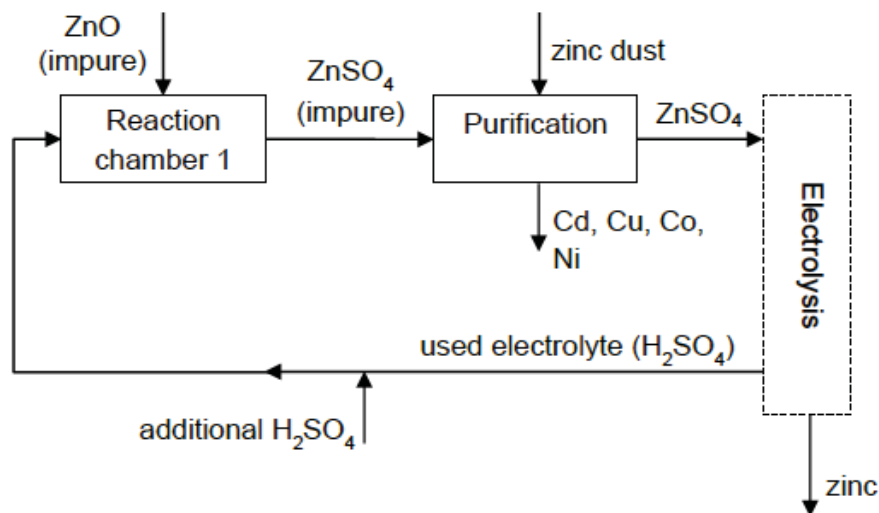

The zinc ore obtained from heating often contains other metals. They form soluble sulfates with sulfuric acid in Reaction Chamber 1. These metals can be removed by adding zinc dust.

After electrolysis, the used electrolyte is recycled. Additional sulfuric acid is added to increase the concentration of the used electrolyte to the required concentration.

- (i) Suggest how zinc dust is able to remove the impurities, such as copper compounds from the solution of zinc sulfate.

.....

 [2]

- (ii) Using the diagram and your knowledge of electrolysis of zinc sulfate, suggest why the used electrolyte contains sulfuric acid.

.....

 [2]

[Total: 10 marks]

OR

B10 A breath analyser is used to estimate the blood alcohol content in a breath sample. The early breath analysers rely on a chemical reaction that takes place between the alcohol, C_2H_5OH , ethanol and acidified potassium dichromate(VI), with silver nitrate acting as a catalyst. If the alcohol is present, the orange acidified potassium dichromate(VI) solution turns green. The equation for the reaction is as follows,

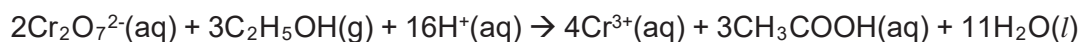

(a) The test for the presence of alcohol is a redox reaction.

Use ideas about oxidation state to explain your answers.

.....

 [2]

(b) Singapore's legal drink-driving limit is 80 mg of alcohol per 100 cm³ of blood.

The concentration of ethanoic acid, CH_3COOH , produced in a man's breath analyser was found to be 0.035 mol/dm³.

Will the man be charged with drink-driving? Show by calculation.

[3]

- (c) The breath analysers used today is actually a fuel cell. The current produced in the fuel cell depends on the concentration of ethanol, C_2H_5OH .

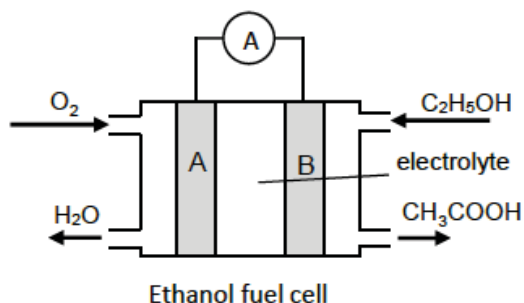

The reactions that occur at the platinum electrodes A and B are as follow,

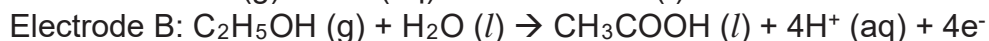
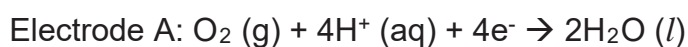

- (i) On the diagram, show the direction of the electron flow in the external circuit. [1]

- (ii) Which electrode, A or B, is the anode?

Explain your reasoning.

.....

..... [2]

- (iii) Write the overall chemical equation for the reaction that occurs in the fuel cell.

..... [1]

- (iv) The electrolyte used is aqueous sulfuric acid.

Explain why it is a more suitable electrolyte as compared to pure water.

.....

..... [1]

[Total: 10 marks]

End of Paper

