

Name	Class	Index Number
------	-------	--------------

## UNITY SECONDARY SCHOOL

PRELIMINARY EXAMINATION 2020

SECONDARY FOUR EXPRESS



**CHEMISTRY 6092/ 01**

**17 SEPTEMBER 2020**

**PAPER 1**

**PAPER 1: 1 HOUR**

**Additional Materials :    Optical Answer Sheet**

### **READ THESE INSTRUCTIONS FIRST**

Write in soft pencil.

Do not use paper clips, highlighters, glue or correction fluid.

Write your name and index number on the Answer Sheet in the spaces provided.

There are **forty** questions on this paper. Answer all questions. For each question there are four possible answers **A, B, C** and **D**.

Choose the **one** you consider correct and record your choice in **soft pencil** on the separate Optical Answer Sheet.

**Read the instructions on the Answer Sheet very carefully.**

Each correct answer will score one mark. A mark will **not** be deducted for a wrong answer.

Any rough working should be done in this booklet.

A copy of the Periodic Table is printed on page 23.

The total mark for this paper is 40 marks.

This paper consists of **23** pages, including this cover page.

- 1 Which of the listed reactions produce a gas that can be collected using the setup below?

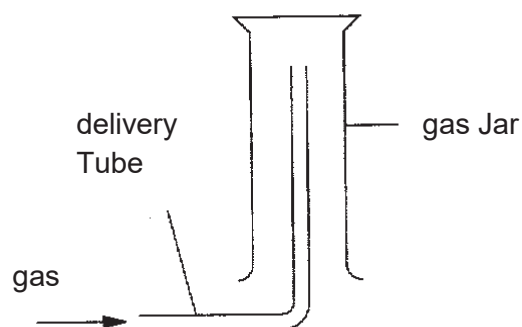

Reaction I	potassium with water
Reaction II	sodium carbonate with hydrochloric acid
Reaction III	zinc with hydrochloric acid
Reaction IV	calcium oxide with water

- A I and II only
- B I and III only
- C II and III only
- D II and IV only
- 2 An inflated balloon goes down because gas molecules can diffuse through the rubber. Four balloons are filled with different gases at the same temperature and pressure.

Which balloon would go down quickest?

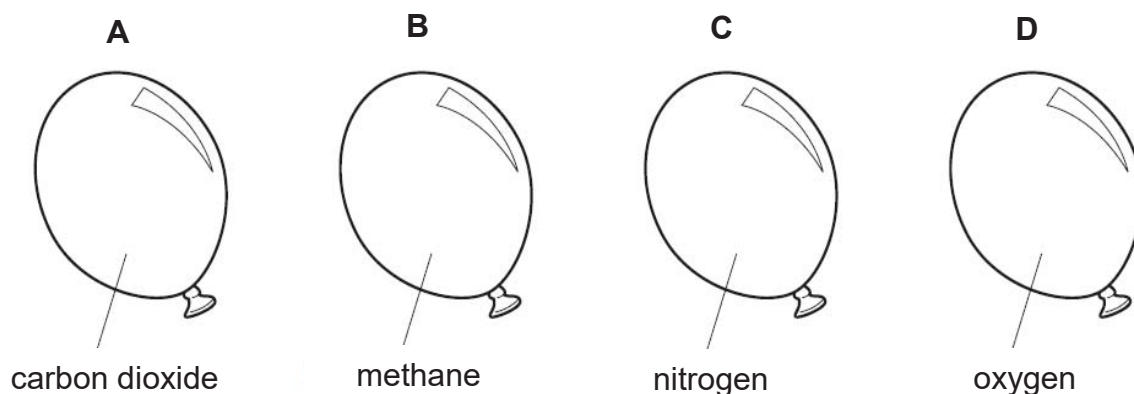

- 3 The diagram shows the apparatus used for the slow reaction between liquid **Y** (boiling point 57 °C) and liquid **Z** (boiling point 80 °C).

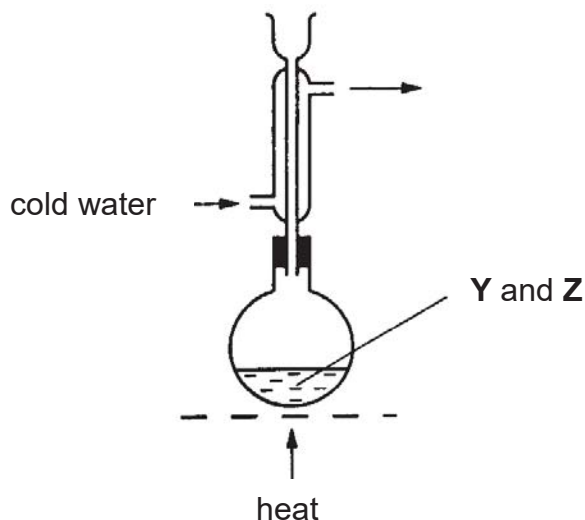

What is the purpose of the condenser?

- A To prevent **Y** and **Z** from escaping before the reaction is complete.
  - B To enable **Y** and **Z** to mix more efficiently.
  - C To prevent the mixture from becoming too hot.
  - D To allow the product to escape as fast as it is formed.
- 4 The descriptions of three substances are given as follows:

substance	description
<b>P</b>	It is made up of identical molecules which burns in excess air to form carbon dioxide and water.
<b>Q</b>	It is a gas which burns in excess air to form water only.
<b>R</b>	Its solution can be separated into three dyes by paper chromatography.

Which of the following correctly classifies substances **P**, **Q** and **R**?

	<b>P</b>	<b>Q</b>	<b>R</b>
<b>A</b>	element	element	compound
<b>B</b>	compound	compound	mixture
<b>C</b>	compound	element	mixture
<b>D</b>	element	mixture	element

- 5 Paper chromatography was used to separate the pigments in a purple ink. The chromatograms obtained at the start of the experiment and after 10 minutes into the experiment are shown below.

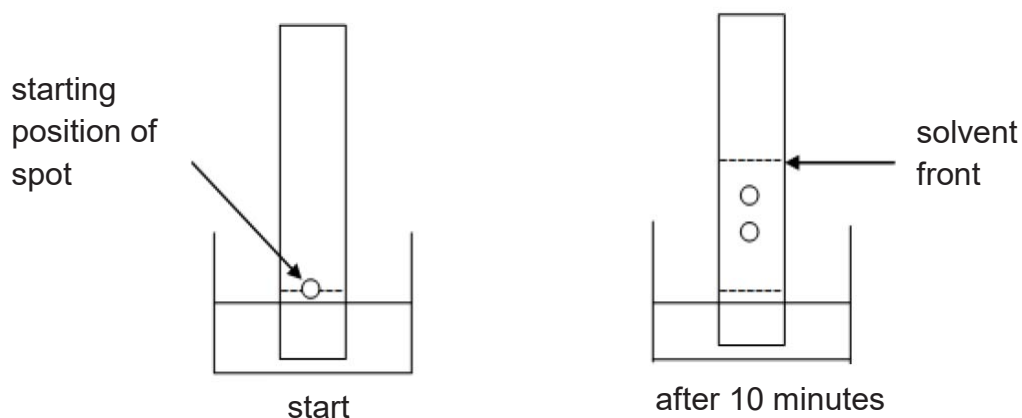

Which of the following diagrams is most likely to indicate the appearance of the chromatogram after a further 15 minutes?

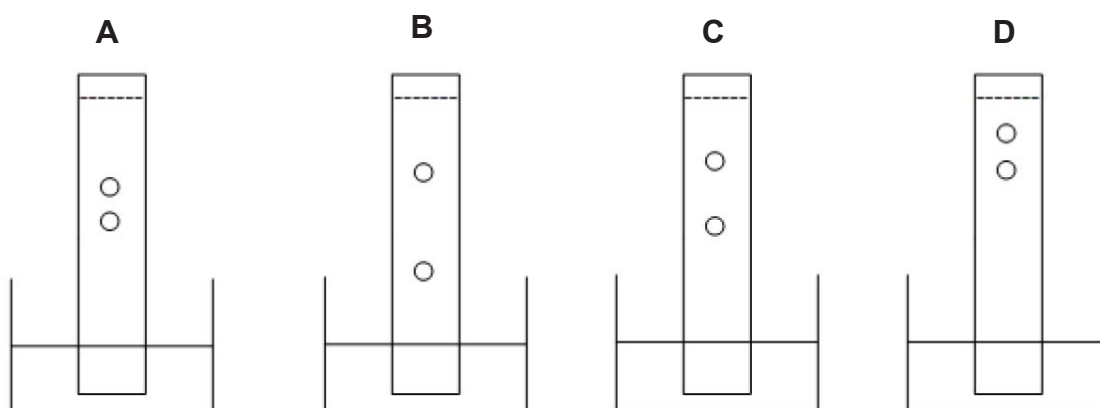

- 6 Element J is found in Group II of the Periodic Table. The symbol for atom J is  ${}^a_b\text{J}$ .

Which entry shows the correct information on the ion formed by isotope atom J?

	number of protons	number of neutrons	number of electrons
<b>A</b>	a	$a - b$	$b + 2$
<b>B</b>	b	$a - b$	$b - 2$
<b>C</b>	b	$a - b + 1$	$b - 2$
<b>D</b>	b	$b - a$	$b - 2$

- 7 An element S, has 2 isotopes of mass numbers 16 and 18. Its average relative atomic mass is 16.4.

What is the proportion of each isotopes in element S?

- A 50% of S-16 and 50% of S-18  
 B 60% of S-16 and 40% of S-18  
 C 70% of S-16 and 30% of S-18  
 D 80% of S-16 and 20% of S-18
- 8 The dot-and-cross diagram (with only the outer electrons) of the compound formed between element X and Z is shown.

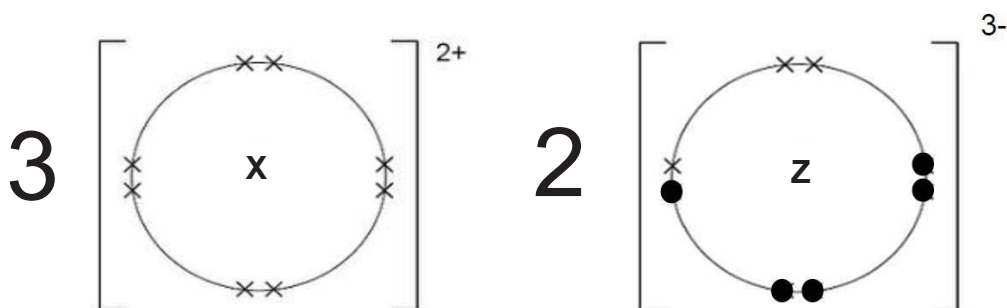

Which of the following is the correct set of formula of the chloride of X and Z?

- A  $XCl$  ,  $Z_3Cl$   
 B  $XCl$  ,  $ZCl_3$   
 C  $XCl_2$  ,  $Z_3Cl$   
 D  $XCl_2$  ,  $ZCl_3$

- 9 The atoms of two elements **X** and **Y** have the structures shown below.

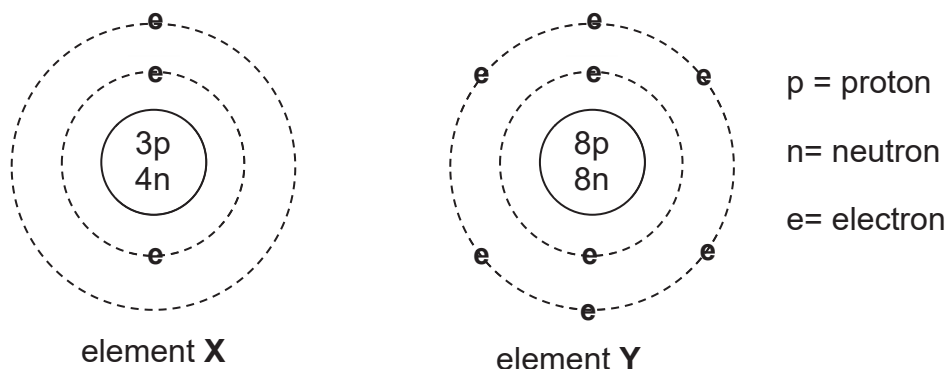

When these two elements combined to form a compound, what is the mass of one mole of this compound?

- A** 11 g  
**B** 12 g  
**C** 23 g  
**D** 30 g
- 10 Copper is a metal. The structure of copper is described as a lattice of positive ions in a 'sea of electrons'.

Which statement/s below about copper is/are correct?

- 1 Copper conducts heat because the positive ions are free to move.
  - 2 Copper conducts heat because the electrons are free to move.
  - 3 Copper ions are held together because of their attraction for each other.
  - 4 Copper has a high melting point due to the strong covalent bonds.
- A** 1, 2 and 3  
**B** 2, 3 and 4  
**C** 2 and 3 only  
**D** 2 only

- 11 Three different tests were carried out on three solids, and the results are summarized in the table below.

tests on substances	results		
	substance 1	substance 2	substance 3
heated gently	no visible change	melted easily	no visible change
electrical conductivity	good conductor in both solid and liquid states	non-conductor in both solid and liquid states	non-conductor in solid state good conductor in liquid state
hit with hammer	flattened	flattened	shattered

Which one of the following best describes the chemical structures of these substances?

	substance 1	substance 2	substance 3
<b>A</b>	Cu	SiO <sub>2</sub>	KBr
<b>B</b>	NaCl	CO <sub>2</sub>	Fe
<b>C</b>	H <sub>2</sub> O	Cu	C (diamond)
<b>D</b>	Fe	At <sub>2</sub>	MgO

- 12 49.2 g of hydrated magnesium sulfate is heated and cooled repeatedly until it reaches a constant mass of 24.0 g.

Assuming only water of crystallisation is lost when hydrated magnesium sulfate is heated, what is the formula of the hydrated magnesium sulfate?

(A<sub>r</sub> of Mg=24, S=32, O=16, H=1)

- A** MgSO<sub>4</sub>.H<sub>2</sub>O
- B** MgSO<sub>4</sub>.3H<sub>2</sub>O
- C** MgSO<sub>4</sub>.5H<sub>2</sub>O
- D** MgSO<sub>4</sub>.7H<sub>2</sub>O

- 13 The equations show the reactions involved in the formation of nitric acid,  $\text{HNO}_3$ , from nitrogen.

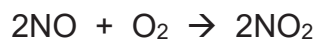

How many moles of nitric acid are formed from 1.50 moles of nitrogen?

- A 0.75  
 B 1.50  
 C 3.00  
 D 4.00
- 14 Below are the overall equations for the manufacture of three fertilisers.

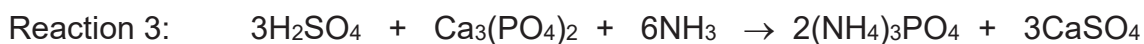

The relative molecular mass,  $M_r$ , of sulfuric acid and of each fertiliser is shown in the table.

		fertilisers		
	$\text{H}_2\text{SO}_4$	$(\text{NH}_4)_2\text{SO}_4$	$\text{Ca}(\text{H}_2\text{PO}_4)_2$	$(\text{NH}_4)_3\text{PO}_4$
$M_r$	98	132	234	149

In each reaction, 98 tonnes of sulfuric acid was used.

Which reaction gave the greatest and least mass of fertiliser?

	greatest mass	least mass
<b>A</b>	1	3
<b>B</b>	1	2
<b>C</b>	2	1
<b>D</b>	3	2

- 15 Tin is extracted from SnO<sub>2</sub> (*M<sub>r</sub>* = 151) by reducing it with coal in a furnace according to the chemical equation.

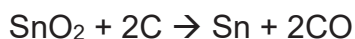

What is the percentage purity of tin ore if 600 g of SnO<sub>2</sub> on reduction produces 82 g of tin?

- A** 17.3%
- B** 34.6%
- C** 41.3%
- D** 82.6%
- 16 The table gives some statements about acids and bases and explanations for these statements.

Which row shows both a correct statement and a correct explanation for the statement?

	statement	explanation
<b>A</b>	ammonia can be made by heating ammonium sulfate with calcium hydroxide	the hydroxide ion acts as a base and removes H <sup>+</sup> from the ammonium ion
<b>B</b>	the pH of a weak acid is higher than the pH of a strong acid of the same concentration	pH shows the extent of ionisation—the more ionised the acid is, the higher the pH
<b>C</b>	calcium hydroxide can be used to control pH in soils	metal hydroxides are acidic and can reduce excess alkalinity
<b>D</b>	when an acid reacts with a metal, the metal is reduced	reduction is gain of electrons

- 17 A mixture of the oxides of two elements of the third period is dissolved in water. This solution is approximately neutral.

What could be the constituents of the mixture?

- A  $Al_2O_3$  and  $MgO$
- B  $Na_2O$  and  $P_4O_{10}$
- C  $Na_2O$  and  $MgO$
- D  $SO_3$  and  $P_4O_{10}$
- 18 Solid Y was added bit by bit with stirring to an aqueous solution of Z. The changes in the pH of the mixture are shown in the graph.

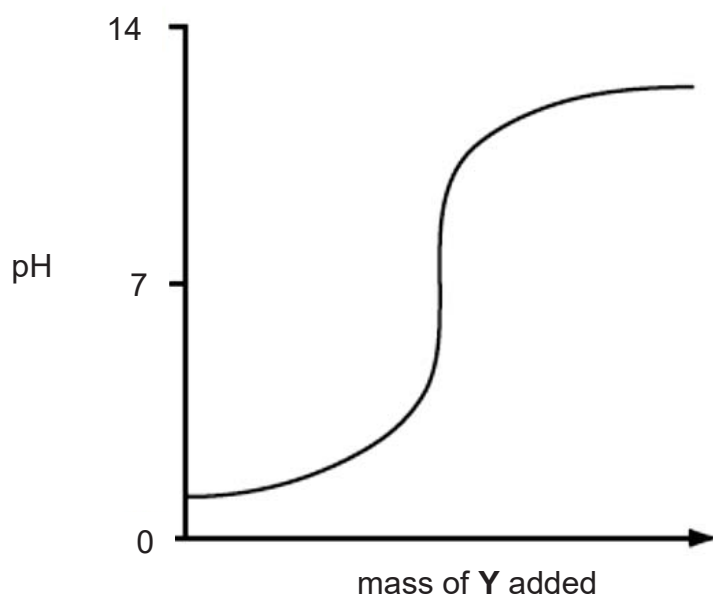

Identify Y and Z.

	Y	Z
A	soluble metal oxide	hydrochloric acid
B	soluble metal oxide	sodium hydroxide
C	insoluble metal oxide	nitric acid
D	insoluble metal oxide	aqueous ammonia

19 Aqueous barium hydroxide reacts with dilute sulfuric acid as shown below.

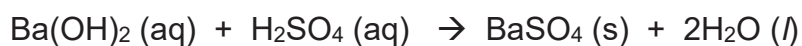

10 cm<sup>3</sup> of 1 mol/dm<sup>3</sup> H<sub>2</sub>SO<sub>4</sub> is slowly added to 10 cm<sup>3</sup> of 1 mol/dm<sup>3</sup> Ba(OH)<sub>2</sub>.

Study the three statements below.

The electrical conductivity of the mixture

- I decreases while the 10 cm<sup>3</sup> of sulfuric acid is being added.
- II Increases if more sulfuric acid is added after the first 10 cm<sup>3</sup>.
- III Increases if aqueous barium hydroxide is added after the first 10 cm<sup>3</sup> sulfuric acid.

Which of the statements are correct?

- A I, II and III
- B I and II
- C I and III
- D II and III

20 The oxides of three elements, **T**, **U** and **V**, are added to water.

	oxide of <b>T</b>	oxide of <b>U</b>	oxide of <b>V</b>
water added	dissolved to form a solution of pH 2	insoluble	dissolved to form a solution of pH 10

The oxide of U is black in colour.

What are **T**, **U** and **V**?

	<b>T</b>	<b>U</b>	<b>V</b>
<b>A</b>	calcium	aluminium	sulfur
<b>B</b>	calcium	copper	sulfur
<b>C</b>	sulfur	aluminium	calcium
<b>D</b>	sulfur	copper	calcium

- 21 Chlorine gas is passed through a heated tube containing sodium bromide powder and potassium iodide powder. Gas **P** and gas **Q** are produced in the process.

Which gas **P** or **Q** is more reactive? What could be the explanation for it?

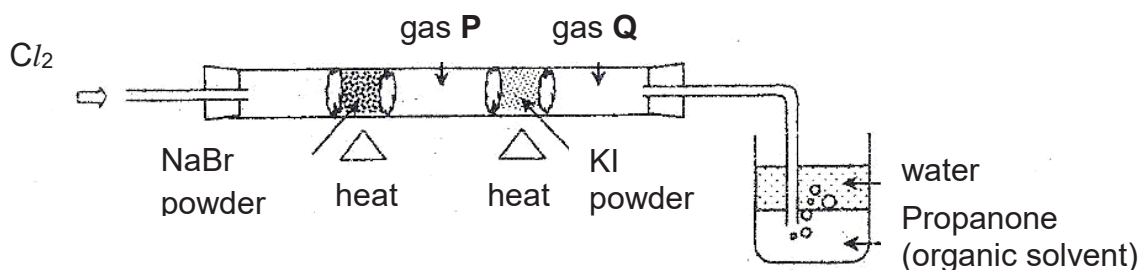

	more reactive gas	explanation
<b>A</b>	<b>P</b>	<b>P</b> has larger atomic radius and loses electrons more easily.
<b>B</b>	<b>P</b>	<b>P</b> has smaller atomic radius and stronger attraction for electrons.
<b>C</b>	<b>Q</b>	<b>Q</b> has smaller atomic radius and stronger attraction for electrons.
<b>D</b>	<b>Q</b>	<b>Q</b> has larger atomic radius and loses electrons more easily.

- 22 The diagram shows part of the Periodic Table.

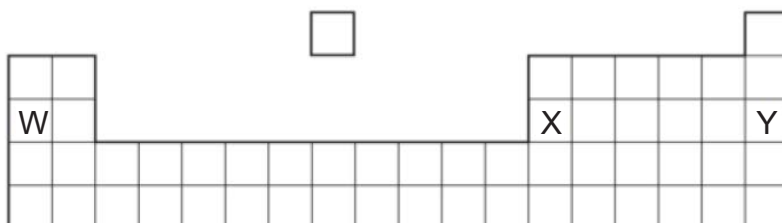

Which of the following about the elements W, X and Y is correct?

	forms an amphoteric oxide	exist as single atoms and is chemically unreactive	forms a carbonate which does not decompose on heating
<b>A</b>	W	X	Y
<b>B</b>	W	Y	X
<b>C</b>	X	W	Y
<b>D</b>	X	Y	W

- 23 Four separate solutions are prepared so that each solution contains 1 g of one of the ions  $\text{Fe}^{2+}$ ,  $\text{Fe}^{3+}$ ,  $\text{Cu}^{2+}$  and  $\text{Zn}^{2+}$ . To each solution is added an excess of aqueous ammonia solution and the mass of any resulting precipitate is found.

Which one of the following diagrams illustrates the results?

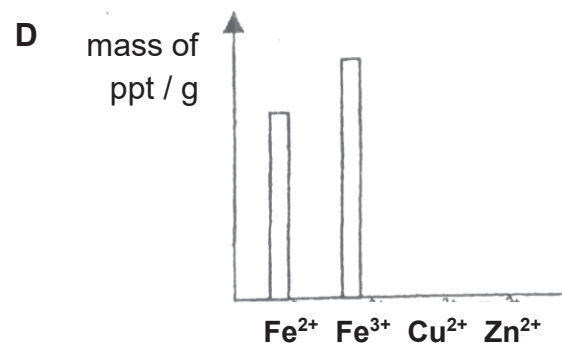
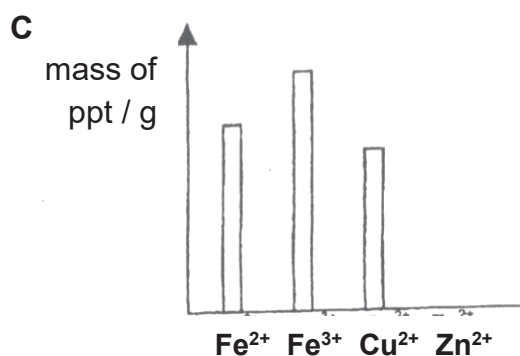
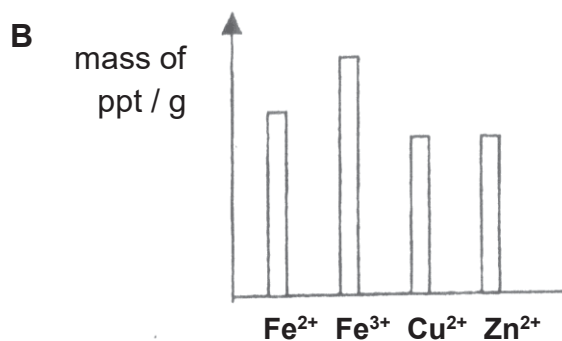
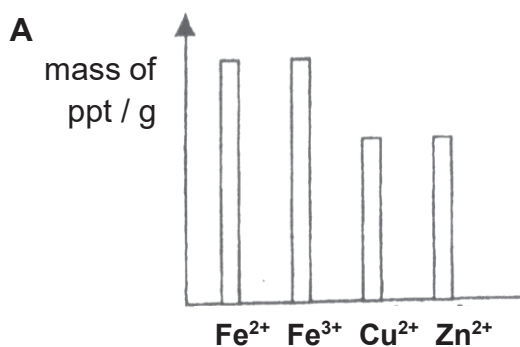

- 24 **W** is a white solid mixture that has the following properties.

**W** dissolves in water.

When dilute hydrochloric acid is added to an aqueous solution of **W**, bubbles are produced.

When chlorine is bubbled through an aqueous solution of **W**, the solution turns red-brown.

What are the substances present in **W**?

- A** calcium carbonate,  $\text{CaCO}_3$ , and potassium bromide,  $\text{KBr}$
- B** copper(II) carbonate,  $\text{CuCO}_3$ , and magnesium iodide,  $\text{MgI}_2$
- C** sodium carbonate,  $\text{Na}_2\text{CO}_3$ , and sodium bromide,  $\text{NaBr}$
- D** sodium nitrate,  $\text{NaNO}_3$ , and ammonium bromide,  $\text{NH}_4\text{Br}$

25 The diagram below shows a reaction scheme involving a metallic element **G**.

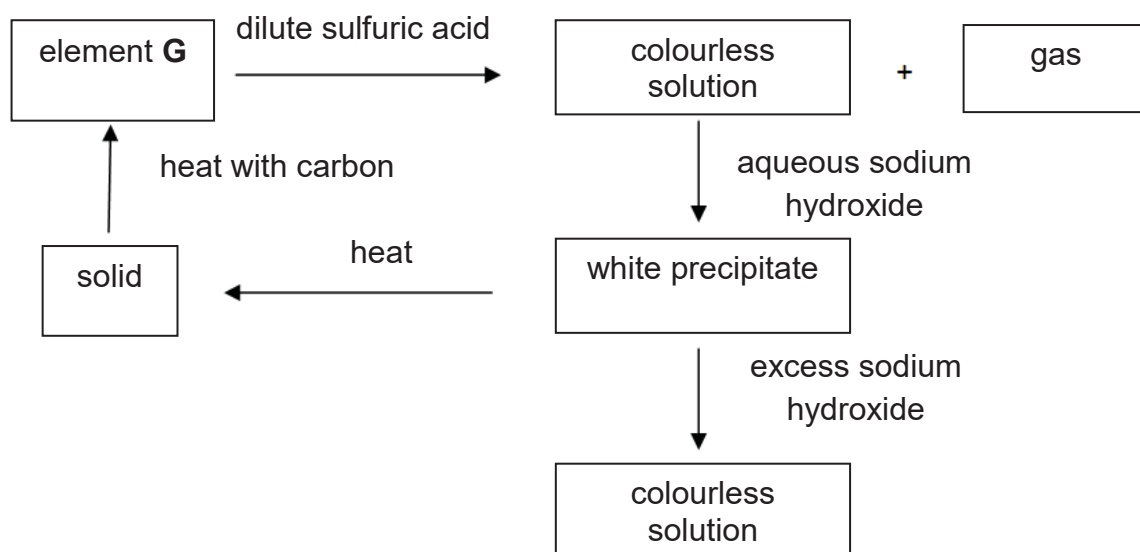

What could be the element **G**?

- A aluminium
  - B calcium
  - C lead
  - D zinc
- 26 Which of the following processes is exothermic?
- A boiling of water to form steam
  - B conversion of glucose to carbon dioxide and water during respiration
  - C formation of glucose and oxygen during photosynthesis
  - D thermal decomposition of zinc carbonate into zinc oxide and carbon dioxide

- 27 The table below compares the strength of the bonds for reactions of the following type.



Which combination of bonds would result in the most exothermic reaction?

	bonds in P <sub>2</sub>	bonds in Q <sub>2</sub>	bonds in PQ
<b>A</b>	strong	strong	strong
<b>B</b>	strong	strong	weak
<b>C</b>	weak	weak	strong
<b>D</b>	weak	weak	weak

- 28 Waste gases from a car engine are passed through a catalytic converter to remove the pollutant gases.

One of the pollutant gases is nitrogen monoxide. The equation shows how it is removed.



Which statement about the reaction is **not** correct?

- A** The oxidation state of nitrogen changes from +4 to 0.
- B** The oxidation state of carbon changes from +2 to +4.
- C** The oxidation state of oxygen is unchanged.
- D** The reaction is a redox reaction.

- 29 The diagram shows different energy paths, **P** and **Q**, and energy levels for a reaction represented by the following equation :

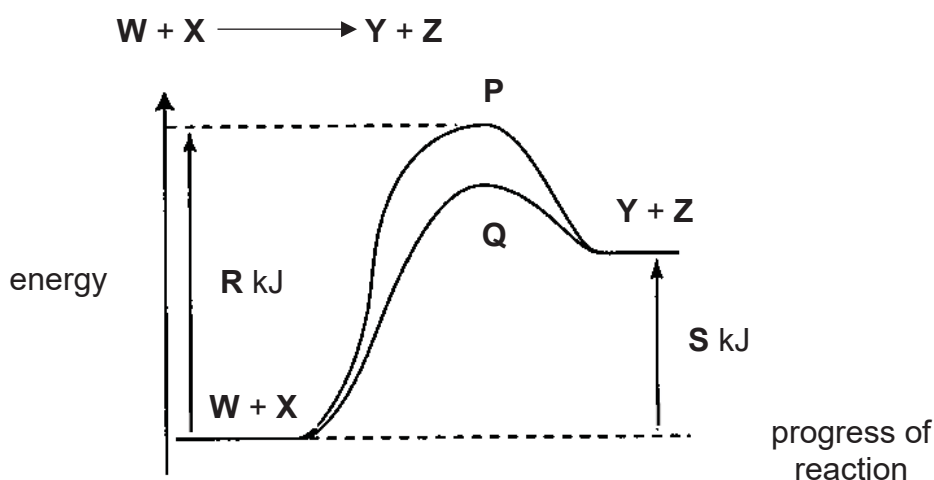

- Which of the following conclusions can be made based on the diagram?
- A** enthalpy change of the reaction equals  $(R - S)$  kJ/mol
- B** the pathway **Q** is achieved by using a catalyst
- C** the temperature of the surrounding increases when **Y** and **Z** are formed
- D** more products **Y** and **Z** are formed through path **Q** than through path **P**
- 30 Early photographers experimented with the oxidation of magnesium powder to produce an intense flash of light. In the presence of oxygen from the air, magnesium reacts according to the equation.



When 0.24 g of magnesium reacts with oxygen, what would be the energy released?

- A** 120 kJ
- B** 240 kJ
- C** 300 kJ
- D** 600 kJ

31 Zinc can be extracted from its ore, zinc sulfide, using the set-up shown below.

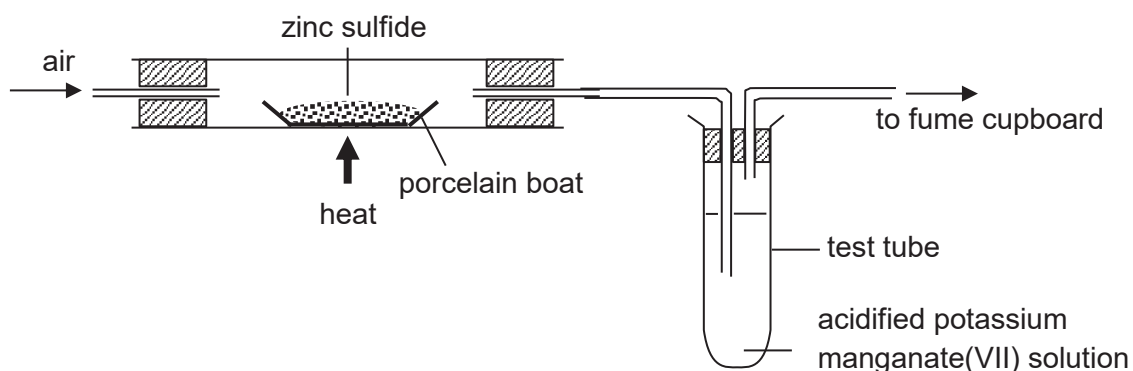

Which of the following descriptions about the set-up is correct?

	acidified potassium manganate(VII) acts as a/an	colour of solid in porcelain boat
<b>A</b>	oxidising agent	white
<b>B</b>	oxidising agent	yellow
<b>C</b>	reducing agent	grey
<b>D</b>	reducing agent	yellow

32 Which statement about the production of iron from iron (III) oxide in the blast furnace is correct?

- A** Calcium carbonate (limestone) removes the basic impurities.
- B** Carbon is oxidised to carbon monoxide by carbon dioxide.
- C** Carbon monoxide oxidises iron (III) oxide to iron.
- D** Molten iron floats on the molten slag.

- 33** Four identical pieces of steel were coated with four different substances on only one half of the steel as shown below. The steel pieces were then left in test tubes full of water for some days.

Which piece of steel is least likely to show rusting?

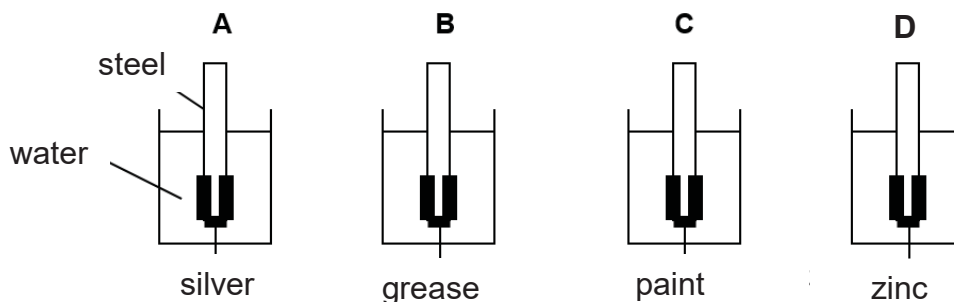

- 34** Three metallic oxide powders containing metals **R**, **S** and **T** are heated strongly in a hard glass tube as shown below. At the same time carbon monoxide gas is directed through the tube.

Oxide of **R** reacts slowly, oxide of **T** glows strongly while oxide of **S** does not undergo any changes.

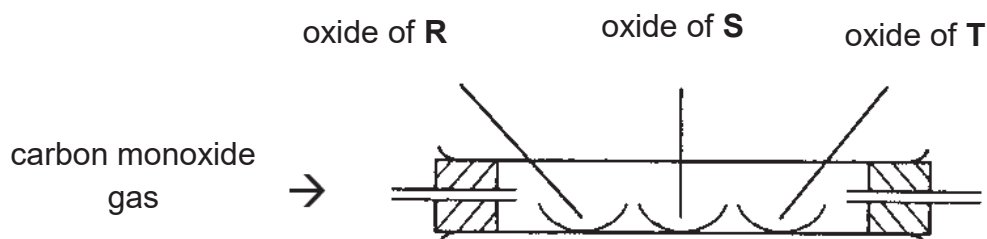

Based on these observations, arrange **R**, **S**, **T** and carbon in descending order of reactivity.

- A** **R**, **S**, **T**, carbon  
**B** **T**, **R**, carbon, **S**  
**C** **S**, carbon, **R**, **T**  
**D** **T**, carbon, **R**, **S**

- 35 In the graph below, curve **X** was obtained by the reaction between 100 cm<sup>3</sup> of 1 mol/dm<sup>3</sup> hydrochloric acid and excess zinc granules.

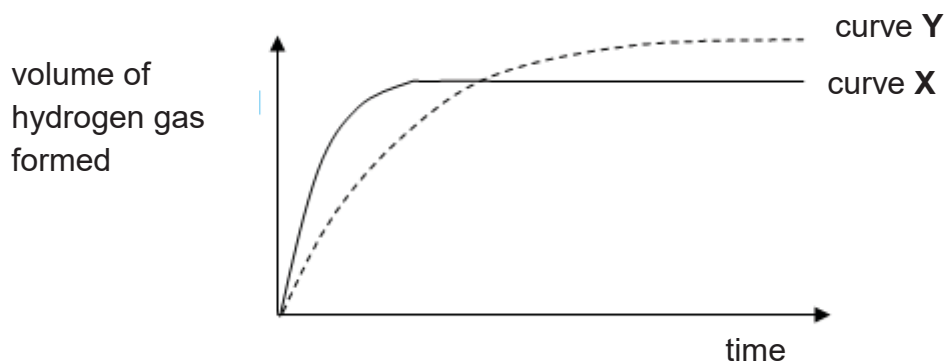

Which of the following changes would produce curve **Y**?

- A adding the same amount of zinc powder instead of zinc granules
  - B increasing the temperature by 10 °C
  - C using 200 cm<sup>3</sup> of 0.8 mol/dm<sup>3</sup> hydrochloric acid instead of 100 cm<sup>3</sup> of 1 mol/dm<sup>3</sup> hydrochloric acid
  - D using 50 cm<sup>3</sup> of 1.5 mol/dm<sup>3</sup> hydrochloric acid instead of 100 cm<sup>3</sup> of 1 mol/dm<sup>3</sup> hydrochloric acid
- 36 To reduce atmospheric pollution, the waste gases from a coal-burning power station are passed through a wet suspension of powdered calcium carbonate.

Which waste gas will **not** be removed by powdered calcium carbonate?

- A carbon monoxide, CO
- B nitrogen dioxide, NO<sub>2</sub>
- C phosphorus(V) oxide, P<sub>2</sub>O<sub>5</sub>
- D sulfur dioxide, SO<sub>2</sub>

- 37 Which statement about some air pollutants is correct?
- A Carbon monoxide produced from complete combustion of fuels causes global warming.
  - B Nitrogen emitted by internal combustion engines reacts with oxygen to form nitrogen oxides.
  - C Ozone produced due to photochemical reactions is harmful to aquatic life.
  - D Sulfur dioxide produced in motor vehicles causes corrosion of limestone buildings.

- 38 In the diagram below each cell contains an aqueous solution of a single salt and all four electrodes are graphites. Electrodes **Q** and **S** increase in mass during the electrolysis but **no** gas is given off at **Q** or **S**.

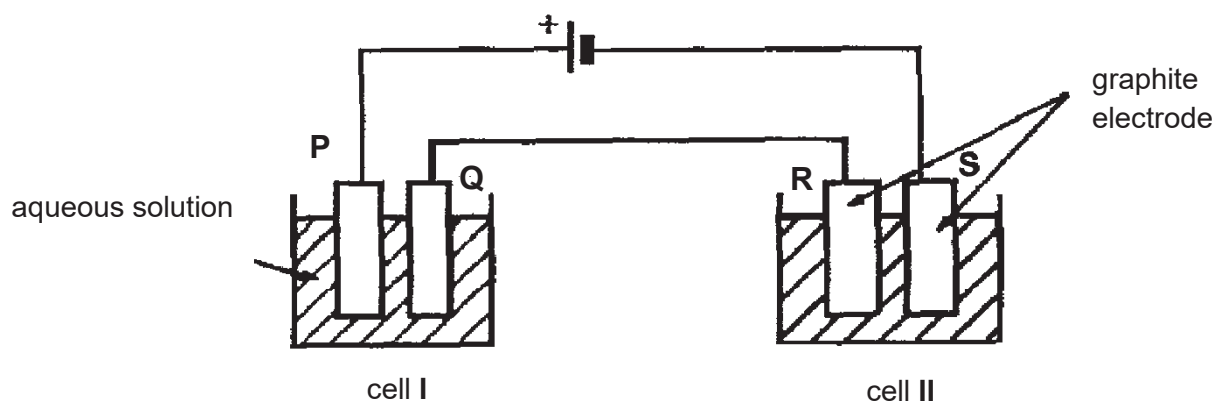

If an increase in mass of **Q** is greater than the increase of mass of **S** in the same time, which of the following statements is necessarily true?

- A The cation discharged in Cell I is different from the cation discharged in Cell II.
- B The anion of the solute in Cell I is different from the anion of the solute in Cell II.
- C The solution in Cell I is more concentrated than the solution in Cell II.
- D The loss of mass of electrode P is less than the loss of mass of electrode R.

- 39 Four metals, tin, **x**, **y** and **z** were connected in pairs at the metal electrode and the voltages were recorded.

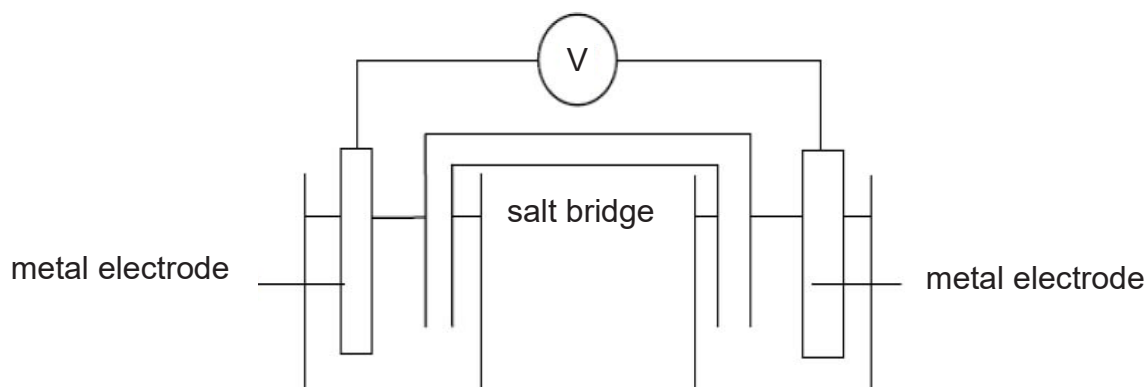

The results obtained are shown in the table below.

negative terminal	positive terminal	voltage (V)
tin	<b>y</b>	+ 1.10
<b>x</b>	tin	+0.90
<b>z</b>	tin	+2.50

What is the order of reactivity of the four metals with the most reactive first?

- A **x**, tin, **y**, **z**
- B **y**, tin, **x**, **z**
- C **z**, tin, **y**, **x**
- D **z**, **x**, tin, **y**

- 40 Which dilute solution, when electrolysed using inert electrodes, would produce the greatest increase in mass of the cathode?

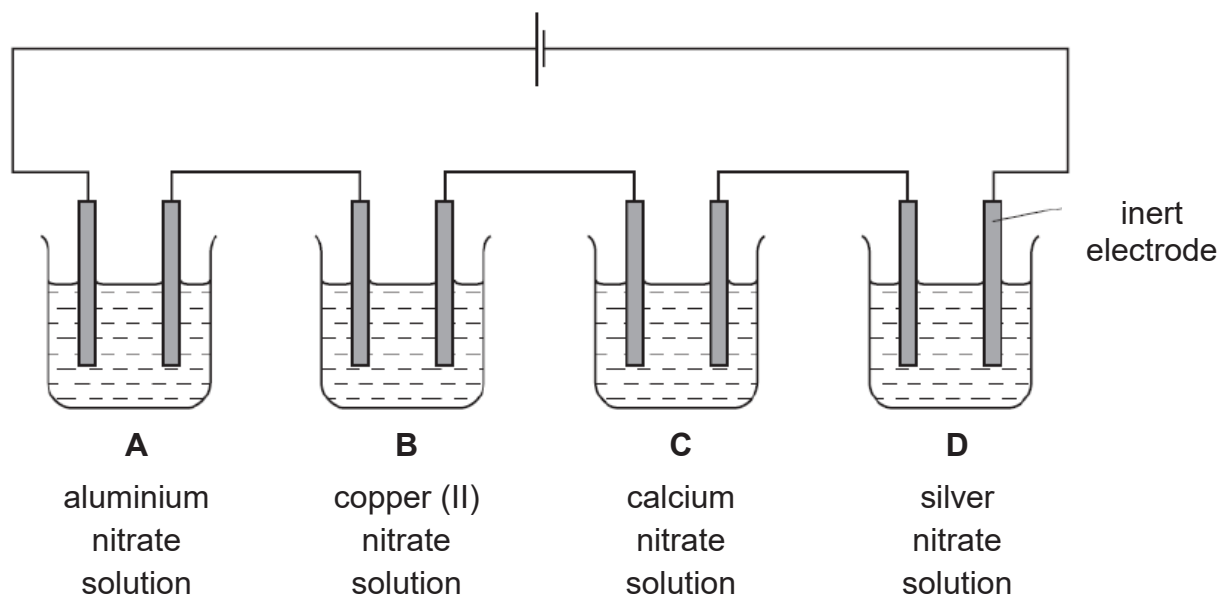



Name	Class	Index Number
------	-------	--------------

## UNITY SECONDARY SCHOOL

PRELIMINARY EXAMINATION 2020

SECONDARY FOUR EXPRESS



**CHEMISTRY 6092/ 02**

**18 SEPTEMBER 2020**

**PAPER 2**

**PAPER 2 : 1 HOUR 45 MIN**

### **READ THESE INSTRUCTIONS FIRST**

Write your name and index number on all the work you hand in.  
Write in dark blue or black pen on both sides of the paper.  
You may use a soft pencil for any diagrams, graphs or rough working.  
Do not use paper clips, highlighters, glue or correction fluid.

#### **Section A**

Answer **all** questions in the spaces provided.

#### **Section B**

Answer **all** three questions, the last question is in the form either/or.  
Answer all questions in the spaces provided.

At the end of the examination, fasten all your work securely together.  
The number of marks is given in brackets [ ] at the end of each question or part question.  
A copy of the Periodic Table is printed on page 26.  
The total mark for this paper is 80 marks.

This paper consists of **26** printed pages, including this cover page.

### Section A (50 marks)

Answer **all** the questions in this section in the spaces provided.

- 1 The table shows the temperature of the thermal decomposition of some metal carbonates.

metal	minimum temperature of decomposition of carbonate/ °C
calcium	840
lead	
lithium	1300
magnesium	402
silver	210

- (a) Construct a chemical equation for the decomposition of magnesium carbonate.

.....[1]

- (b) With reference to the table above, describe how the temperature needed for the decomposition of carbonate relate to the reactivity of the metal.

.....  
.....  
.....  
.....[2]

- (c) Predict the minimum temperature needed for the decomposition of lead(II) carbonate.

Explain your reasoning.

Temperature: .....

Reason:

.....  
.....[1]

- 2 The diagram below shows two important industrial processes producing compounds for many other industries to manufacture plastics compounds, agricultural materials, explosives etc.

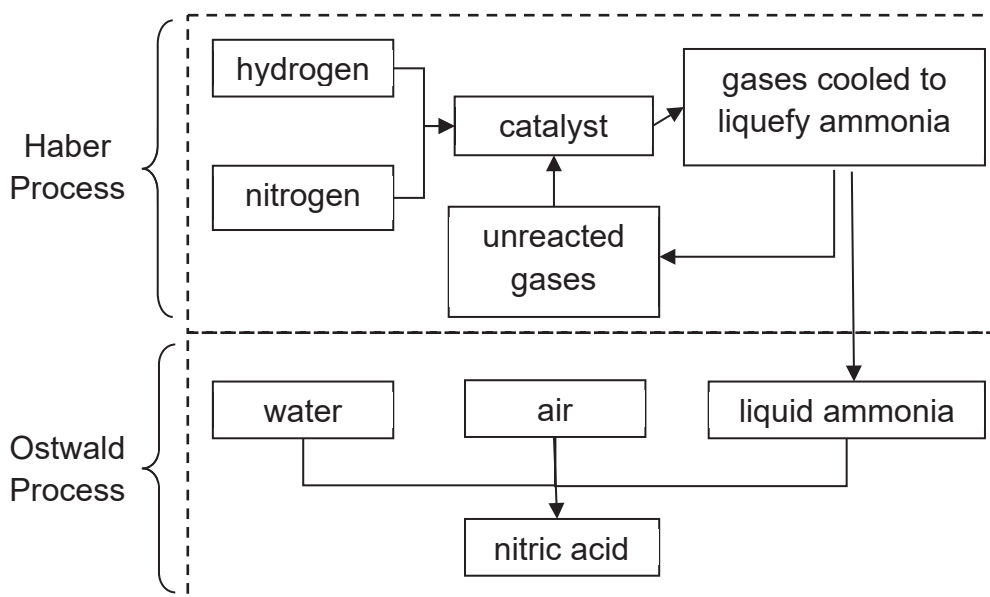

- (a) State the conditions required for the Haber Process.

.....  
 .....  
 .....[1]

- (b) Explain why air is not used as a raw material in the Haber Process.

.....  
 .....  
 .....[1]

- (c) When the products of the Haber and Ostwald Processes are reacted together, a new compound is formed.

Name the compound and state one use of this compound.

.....  
 .....  
 .....[2]

(d) Haber Process : nitrogen to ammonia

Ostwald Process : ammonia to nitric acid

Write down the oxidation states of nitrogen for all three substances. [1]

substance	oxidation state
nitrogen	
ammonia	
nitric acid	

(e) Deduce whether oxidation or reduction has taken place in each process.

(i) Haber  
Process : .....[1]

(ii) Ostwald  
Process: .....[1]

3 In recent years scientists have made tube-shaped structures of carbon called nanotubes.

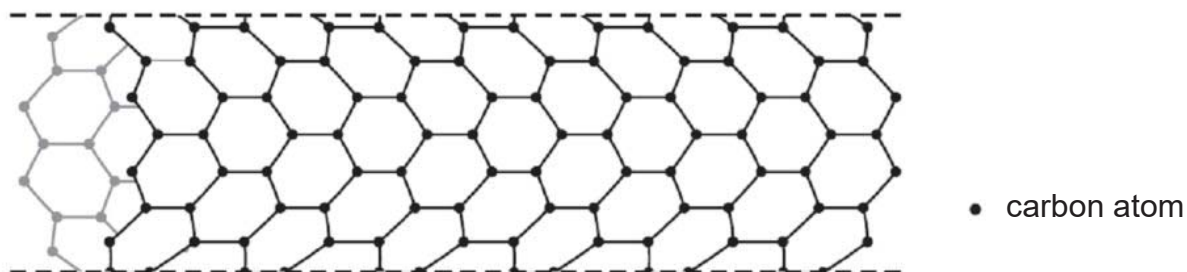

(a) Predict, with explanation, if carbon nanotubes are able to conduct electricity.

.....  
.....  
.....  
.....  
.....[1]

(b) Carbon nanotubes are fifty times stronger than steel, which is a mixture of iron and carbon. Explain, in terms of structure and bonding, why carbon nanotubes are strong.

.....  
 .....  
 .....  
 .....  
 .....[2]

(c) The iron in the steel has metallic bonding. Define metallic bonding.

.....  
 .....[1]

4 Elements **X**, **Y** and **Z** are found in Period 4 of the Periodic Table. The table below shows some information about the oxides of these elements.

	oxides of		
	<b>X</b>	<b>Y</b>	<b>Z</b>
solubility in water	insoluble	Slightly soluble	soluble
reaction with aqueous sodium hydroxide	oxide of <b>X</b> dissolves to form a colourless solution	oxide of <b>Y</b> dissolves to form a colourless solution	oxide of <b>Z</b> remains
reaction with dilute hydrochloric acid	oxide of <b>X</b> dissolves to form a colourless solution	oxide of <b>Y</b> remains	oxide of <b>Z</b> dissolves to form a colourless solution

(a) Based on the information in the table, arrange elements **X**, **Y** and **Z** according to increasing proton number.

.....[1]



(c) A grey deposit is formed on the pieces of aluminium foil.

Explain how this grey solid is formed.

.....  
.....  
.....  
.....[1]

(d) Gas **A** is bubbled into aqueous zinc chloride until there is no further change.

State the observations.

.....  
.....  
.....  
.....[1]





7 Considerable scientific research is taking place to develop hydrogen as a fuel for the future. Scientists are especially interested in developing hydrogen as motor fuel because it burns more cleanly and more efficiently than petrol.

(a) Suggest what is meant by the statement “hydrogen burns more cleanly than petrol.”

.....  
.....  
.....[2]

(b) Scientists use a term called the ‘energy density’ to compare fuels. Energy density is the energy produced from the combustion of one gram of a fuel. It can be calculated from the enthalpy (energy) change of the combustion of a fuel.

It is found that 5473 kJ of energy is released when one mole of petrol consisting of hydrocarbon,  $C_8H_{18}$ , burnt in air. However, 287 kJ of energy is released when one mole of hydrogen burnt in air.

(i) Calculate the energy density of hydrogen and of petrol. Hence, determine which fuel has a greater energy density.

[3]

- (ii) Petrol ( $C_8H_{18}$ ) combusts completely to produce carbon dioxide and water. Complete the energy profile diagram below for the combustion of petrol.

Show the names of the reactants and products, and label the activation energy for the reaction. [2]

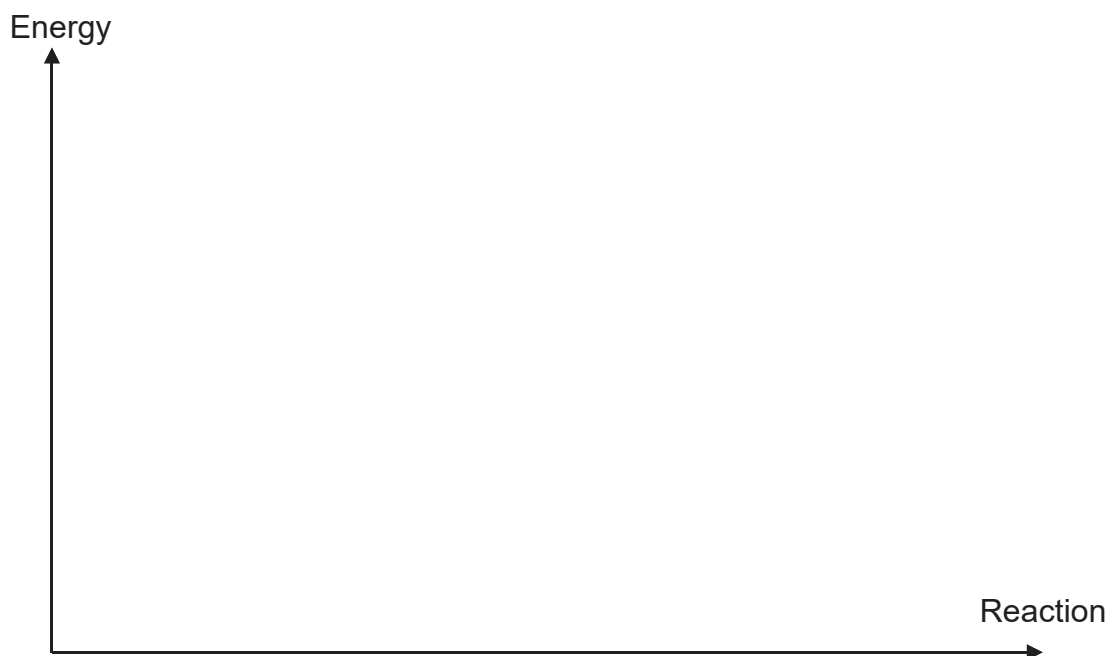

- (iii) Suggest a reason why petrol is the preferred fuel for motor vehicles despite the advantage of using hydrogen.

.....  
.....  
.....  
.....[1]

- (iv) "Biogas" is growing rapidly as an alternative energy supply, particularly in some countries. It is produced when carbohydrates in plants and animal waste were digested by bacteria.

Biogas, which consists mainly of methane, is used as a fuel because of its exothermic reaction with oxygen.

Explain why this reaction is exothermic in terms of bond breaking and bond making.

.....  
.....  
.....  
.....[2]

- 8 Hydrogen fluoride attacks glass and is used to draw on glass. It is prepared by adding concentrated sulfuric acid to calcium fluoride. The reaction takes place at room temperature.



- (a) When 15.6 g of a sample of calcium fluoride was reacted with 12.5 cm<sup>3</sup> of 20.0 mol/dm<sup>3</sup> sulfuric acid at room temperature and pressure, 7.68 dm<sup>3</sup> of hydrogen fluoride was formed.

- (i) What is the limiting reactant in this reaction?

[2]

(ii) Calculate the theoretical volume of hydrogen fluoride that was formed.

[2]

(b) Calculate the percentage purity of calcium fluoride.

[2]

- 9 Chromatography is the general name applied to a series of separation methods that employ a system with two phases of matter; a mobile phase and a stationary phase. Analytes in a mixture to be separated interact with the stationary phase with different affinities. While moving through the system, carried along by the mobile phase (solvent), analytes with a low affinity for the stationary phase will tend to move along rapidly, while those with a high affinity will tend to lag behind. Thin Layer Chromatography (TLC) is a fast and inexpensive form of chromatography that has many uses in the organic laboratory. The retention factor ( $R_f$ ) is simply the fractional distance the solute spot moves along the plate relative to the solvent front. The stationary phase in TLC is typically an adsorbant made of silica gel.

Analgesics are substances that relieve pain. The most common of these is aspirin. Other common analgesics include acetaminophen. Additionally, to counteract the acidic properties of aspirin, an inorganic buffering agent is added to some preparations. In some cases, caffeine is added to counteract the sedative effects of the analgesic.

TLC will be used to analyse a commercial analgesic tablet. The above-mentioned compounds will also be run on the same TLC for comparison. The retention factor value for each standard and each analyte spot produced by the commercial analgesic tablet will be determined. This will then allow the compounds used in the analgesic tablet to be identified.

Literature values of the compounds are listed as followed.

compound	melting point/ °C	retention factor
Acetaminophen	168.0	0.333
Aspirin	136.0	0.639
Caffeine	236.1	0.125

The retention factor values are obtained after each of the components, **X**, **Y** and **Z**, are isolated and were analysed using TLC.

compound	melting point/ °C	retention factor
<b>X</b>	132.1 – 132.2	0.676
<b>Y</b>	166.2 – 168.2	0.378
<b>Z</b>	234.3 – 235.5	0.189

**Source:** <https://infohost.nmt.edu/~jaltig/TLC.pdf>

- (a) Use the literature information provided to name the components, **X**, **Y** and **Z**. [1]

name of <b>X</b>	name of <b>Y</b>	name of <b>Z</b>

- (b) Based on the literature  $R_f$  values, which of the compounds has the highest affinity to the stationary phase, silica gel?

Explain your reasoning.

.....  
.....  
..... [2]

- (c) What can you conclude about the literature melting points and the experimental melting points?

Explain your reasoning.

.....  
.....  
..... [2]







- 11 The diagram shows the electrolysis of three different solutions using inert electrodes.

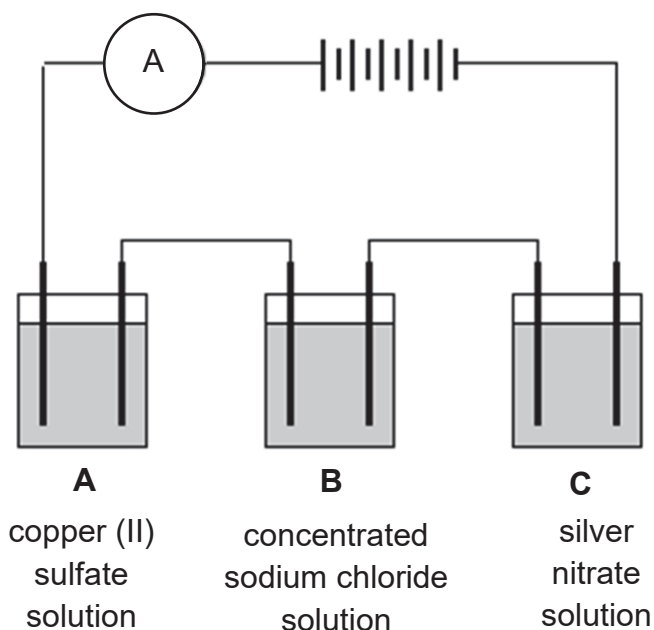

- (a) (i) Write equations for the reactions that happens at each electrode in Cell **B** during electrolysis. Include state symbols.

Cathode: .....

Anode:.....[2]

- (ii) Describe **two** observations that takes place at Cell **B**.

Explain your observations.

.....

.....

.....

.....

.....

.....

.....

.....

.....[4]



**EITHER**

**12** The diagram below shows an electrolytic setup. It consists of cell **A** where the 2 electrodes are zinc and copper and Cell **B** where the 2 electrodes are made of graphite.

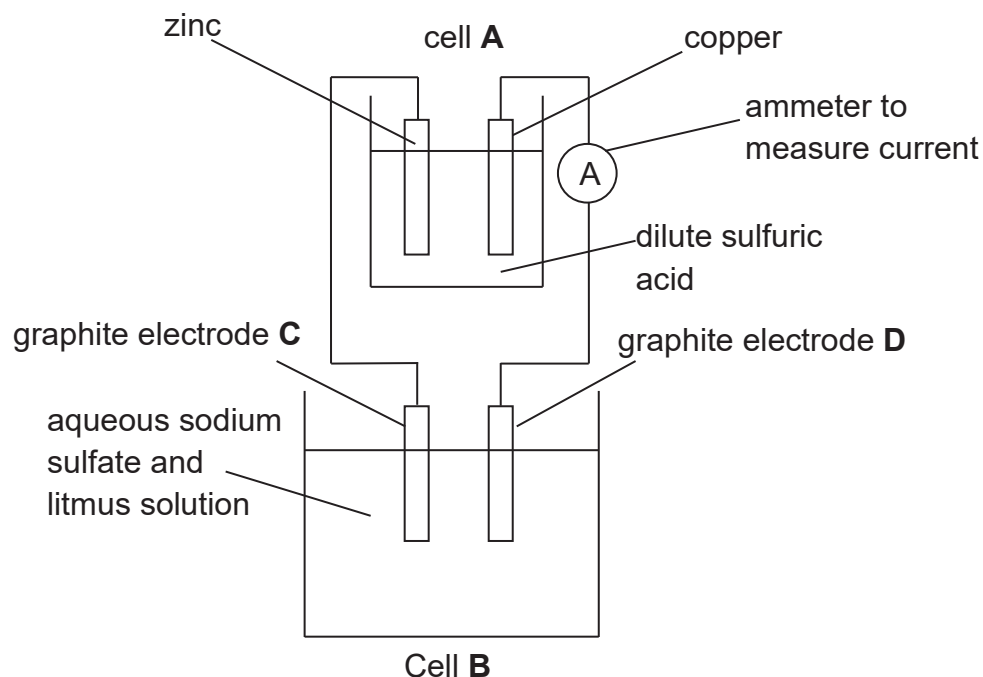

- (a) For Cell **A**,
- (i) Indicate on the diagram the direction of electron flow with an arrow. [1]
  
  - (ii) Write an ionic equation with state symbols for the reaction that takes place at the positive electrode.  
 .....[1]
  
  - (iii) If the dilute sulfuric acid is replaced by ethanol, will there be a reading on the ammeter? Explain your answer.  
 .....  
 .....  
 .....  
 .....[2]

- (iv) Without changing the copper electrode, what change in ammeter reading would be obtained if the zinc electrode is replaced by magnesium?

Explain your answer.

.....  
.....  
.....  
.....[2]

- (b) For cell **B**,

- (i) State clearly the products formed at each electrode.

.....  
.....[1]

- (ii) Write the ionic equation for the reaction that takes place at electrode **D**.

.....[1]

- (iii) The litmus solution around electrode **C** turns blue after some time.

Explain this observation.

.....  
.....[1]

- (iv) When graphite is replaced by aluminium at electrode D, the ammeter shows a reading for a short while before zero is obtained.

Why is there no reading?

.....  
.....[1]

OR

- 12 The table below shows a study of a precipitation reaction between dilute sulfuric acid and aqueous barium hydroxide.

The reaction tubes contain different volumes of barium hydroxide and dilute sulfuric acid as stated in the table. To each tube, two drops of methyl orange indicator are added. Precipitate occurs in all reaction tubes and after 20 minutes, the height of the precipitate in each tube is measured and recorded.

reaction tube	1	2	3	4	5	6
volume of 0.50 mol/dm <sup>3</sup> of barium hydroxide (cm <sup>3</sup> )	5.0	5.0	5.0	5.0	5.0	5.0
volume of 1.00 mol/dm <sup>3</sup> of sulfuric acid (cm <sup>3</sup> )	1.0	1.5	2.0	2.5	3.0	3.5
height of precipitate (cm)	2.5	3.0	3.5	4.0	4.0	

- (a) What is the name of the precipitate produced in the reaction?

.....[1]

- (b) What is the colour of the solution that is observed in

- (i) reaction tube 1?

.....[1]

- (ii) reaction tube 5?

.....[1]

- (c) (i) Predict the height of the precipitate in reaction tube 6.

.....[1]

- (ii) Explain briefly for your answer to c(i).

.....

.....[1]

(d) The electrical conductivity of each reaction tube was measured.

Sketch a graph of electrical conductivity against the reaction tube number.

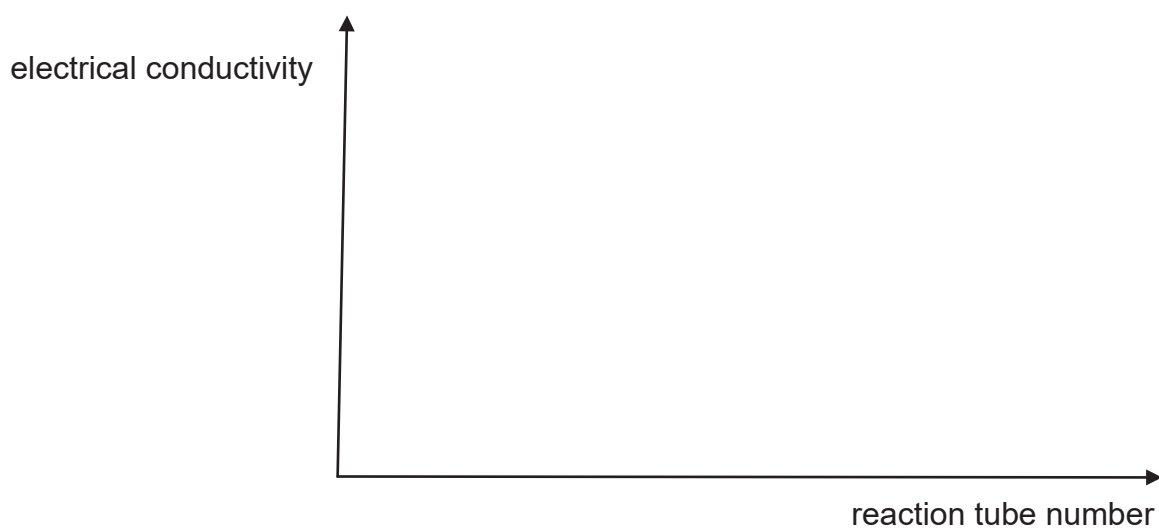

[2]

(e) A student tried to prepare two salts, lead (II) sulfate and sodium nitrate, using the method described in the paragraph below.

Aqueous lead (II) nitrate was mixed with aqueous sodium sulfate and the precipitate of lead (II) sulfate was obtained by filtration. The residue was dried in an oven. The filtrate was heated until the solution is saturated. Crystals of sodium nitrate was formed when the saturated solution was cooled.

(i) State one missing step in the preparation of lead (II) sulfate.

.....  
.....  
.....[1]

(ii) Explain why the student could not obtain pure crystals of sodium nitrate using the method described above.

.....  
.....  
.....[1]

(iii) Name a suitable method to prepare pure crystals of sodium nitrate.

.....[1]

End of Paper

# The Periodic Table of Elements

		Group																																																																									
I	II	III	IV	V	VI	VII	0																																																																				
3 Li lithium 7	4 Be beryllium 9	11 Na sodium 23	12 Mg magnesium 24	19 K potassium 39	20 Ca calcium 40	21 Sc scandium 45	22 Ti titanium 48	23 V vanadium 51	24 Cr chromium 52	25 Mn manganese 55	26 Fe iron 56	27 Co cobalt 59	28 Ni nickel 59	29 Cu copper 64	30 Zn zinc 65	31 Ga gallium 70	32 Ge germanium 73	33 As arsenic 75	34 Se selenium 79	35 Br bromine 80	36 Kr krypton 84	37 Rb rubidium 85	38 Sr strontium 88	39 Y yttrium 89	40 Zr zirconium 91	41 Nb niobium 93	42 Mo molybdenum 96	43 Tc technetium -	44 Ru ruthenium 101	45 Rh rhodium 103	46 Pd palladium 106	47 Ag silver 108	48 Cd cadmium 112	49 In indium 115	50 Sn tin 119	51 Sb antimony 122	52 Te tellurium 128	53 I iodine 127	54 Xe xenon 131	55 Cs caesium 133	56 Ba barium 137	57-71 lanthanoids	72 Hf hafnium 178	73 Ta tantalum 181	74 W tungsten 184	75 Re rhenium 186	76 Os osmium 190	77 Ir iridium 192	78 Pt platinum 195	79 Au gold 197	80 Hg mercury 201	81 Tl thallium 204	82 Pb lead 207	83 Bi bismuth 209	84 Po polonium -	85 At astatine -	86 Rn radon -	87 Fr francium -	88 Ra radium -	89-103 actinoids	104 Rf rutherfordium -	105 Db dubnium -	106 Sg seaborgium -	107 Bh bohrium -	108 Hs hassium -	109 Mt meitnerium -	110 Ds darmstadtium -	111 Rg roentgenium -	112 Cn copernicium -	113 Nh nihonium -	114 Fl flerovium -	115 Lv livermorium -	116 Ts tennessine -	117 Oh oganeson -	118 Og ogessonium -

1  
H  
hydrogen  
1

**Key**  
proton (atomic) number  
atomic symbol  
name  
relative atomic mass

lanthanoids	57 La lanthanum 139	58 Ce cerium 140	59 Pr praseodymium 141	60 Nd neodymium 144	61 Pm promethium -	62 Sm samarium 150	63 Eu europium 152	64 Gd gadolinium 157	65 Tb terbium 159	66 Dy dysprosium 163	67 Ho holmium 165	68 Er erbium 167	69 Tm thulium 169	70 Yb ytterbium 173	71 Lu lutetium 175
actinoids	89 Ac actinium -	90 Th thorium 232	91 Pa protactinium 231	92 U uranium 238	93 Np neptunium -	94 Pu plutonium -	95 Am americium -	96 Cm curium -	97 Bk berkelium -	98 Cf californium -	99 Es einsteinium -	100 Fm fermium -	101 Md mendelevium -	102 No nobelium -	103 Lr lawrencium -

The volume of one mole of any gas is 24 dm<sup>3</sup> at room temperature and pressure (r.t.p.).

