

Visit

FREETESTPAPER.com

for more papers



Website: freetestpaper.com



[Facebook.com/freetestpaper](https://www.facebook.com/freetestpaper)



[Twitter.com/freetestpaper](https://www.twitter.com/freetestpaper)

Name:		Index Number:		Class:	
--------------	--	----------------------	--	---------------	--



CATHOLIC HIGH SCHOOL
Preliminary Examination
Secondary 4 'O' Level Programme

CHEMISTRY

Paper 1

6092/01

27 August 2024
 1 hour

Additional Materials: Multiple Choice Answer Sheet

READ THESE INSTRUCTIONS FIRST

Write in soft pencil.

Do not use staples, pencil clips, glue or correction fluid.

Write your name, index number and class on the Answer Sheet in the spaces provided.

There are **forty** questions in this Paper. Answer **all** questions. For each question there are four possible answers **A, B, C and D**.

Choose the **one** you consider correct and record your choice in **soft pencil** on the separate Answer Sheet.

Each correct answer will score one mark. A mark will not be deducted for a wrong answer.

Any rough working should be done in this booklet.

A copy of the Periodic Table is given on page **16**.

The use of an approved scientific calculator is expected, where appropriate.

For examiner's use only:

Total	/ 40
--------------	-------------

This document consists of **16** printed pages.

[Turn Over

2

- 1 When calcium carbonate is added to dilute hydrochloric acid, carbon dioxide gas is released.

Three sets of apparatus are shown.

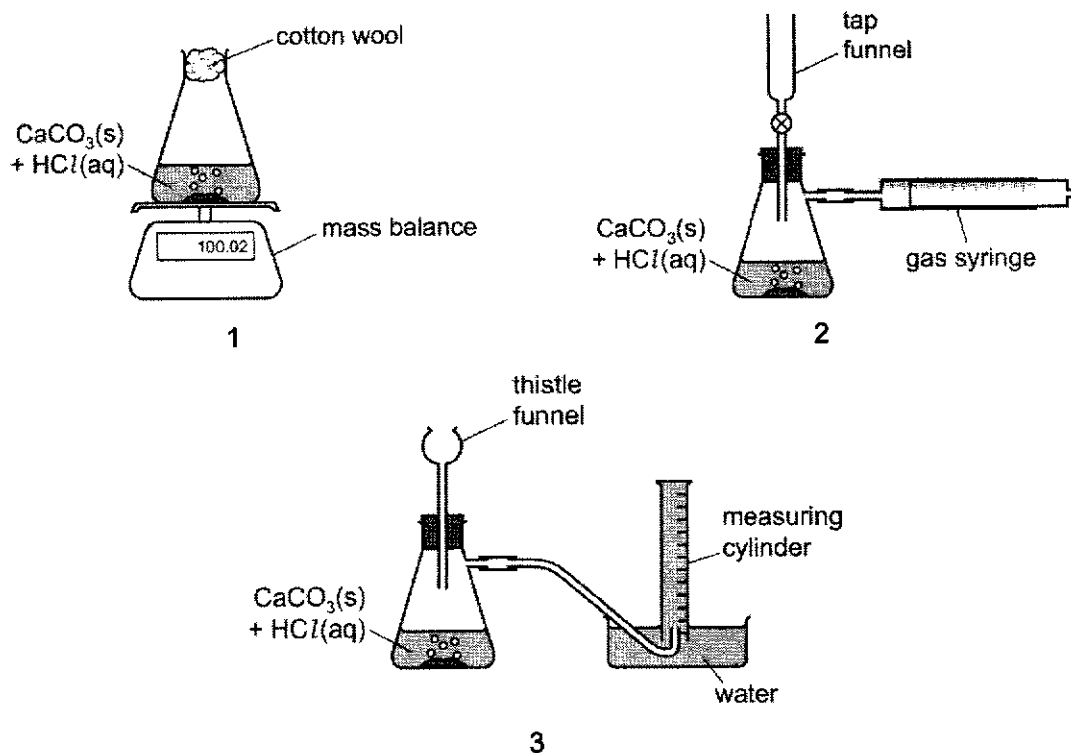

Which sets of apparatus are suitable, together with a stopwatch, for following the rate of this reaction?

- A 1, 2 and 3 B 1 and 2 only C 1 and 3 only D 2 and 3 only
- 2 Solutions of $\text{Ca}(\text{NO}_3)_2$ and $\text{Cu}(\text{NO}_3)_2$ separately undergo a series of reactions.

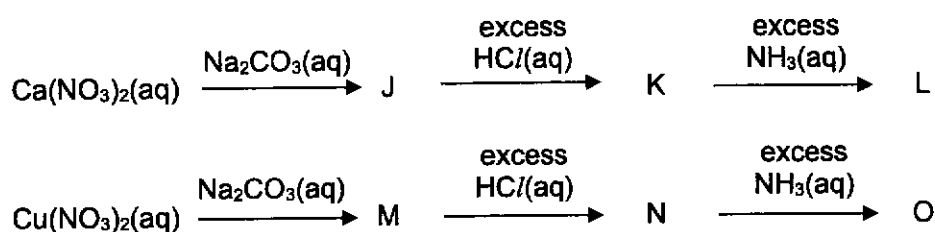

J, K and L are calcium compounds.

M, N and O are copper(II) compounds.

How many of J, K, L, M, N and O contain precipitates?

- A 2 B 3 C 4 D 5

3

- 3 An excess of sodium hydroxide solution is added to a solution of salt P and warmed. A gas that turns damp red litmus paper blue is only given off after aluminium foil is added to the hot solution.

What is salt P?

- A ammonium chloride
 B ammonium nitrate
 C sodium chloride
 D sodium nitrate
- 4 The diagram shows the apparatus used to separate hexane (boiling point, 70 °C) and heptane (boiling point, 98 °C).

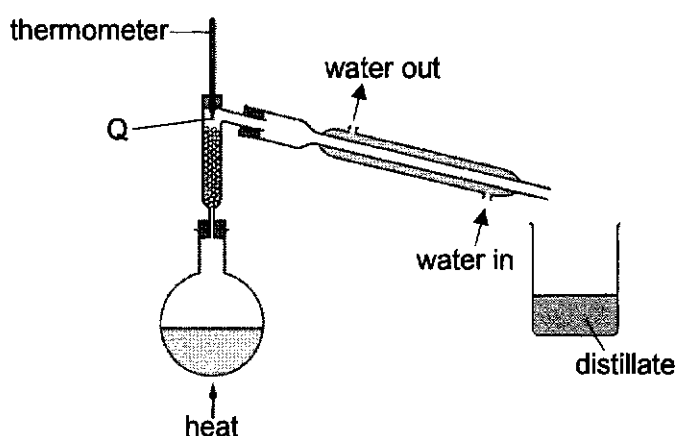

Which graph would be obtained if the temperature at point Q was plotted against the total volume of distillate collected?

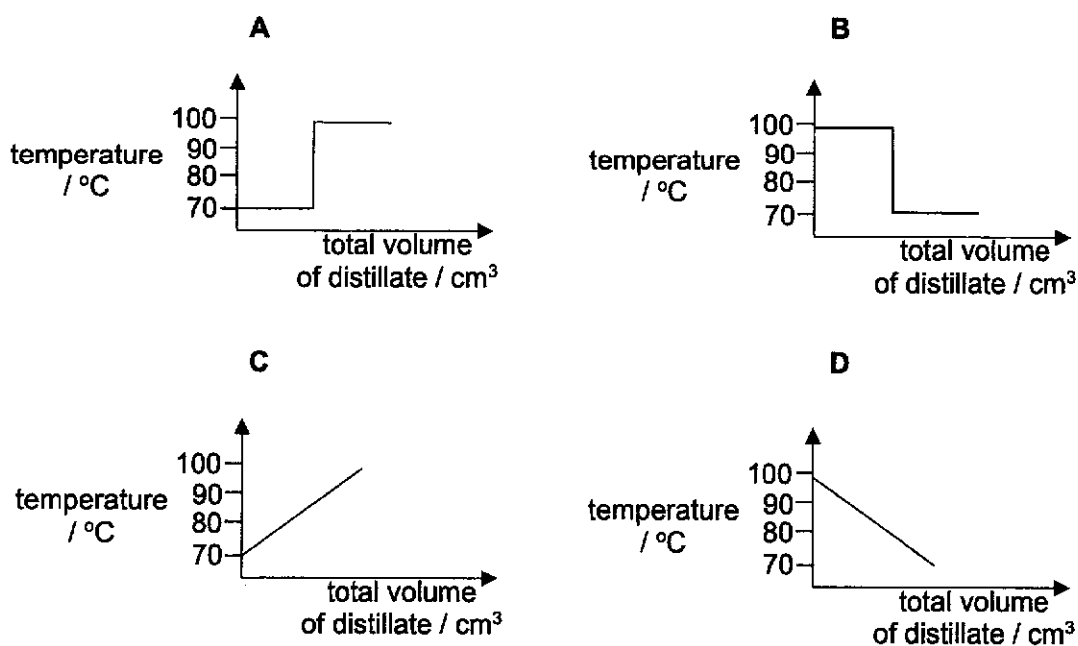

[Turn Over

5 Four experiments, each containing a different acidic gas, are set up as shown.

The dividing glass plates are removed at the same time.

In which set of apparatus does the litmus paper turn red first?

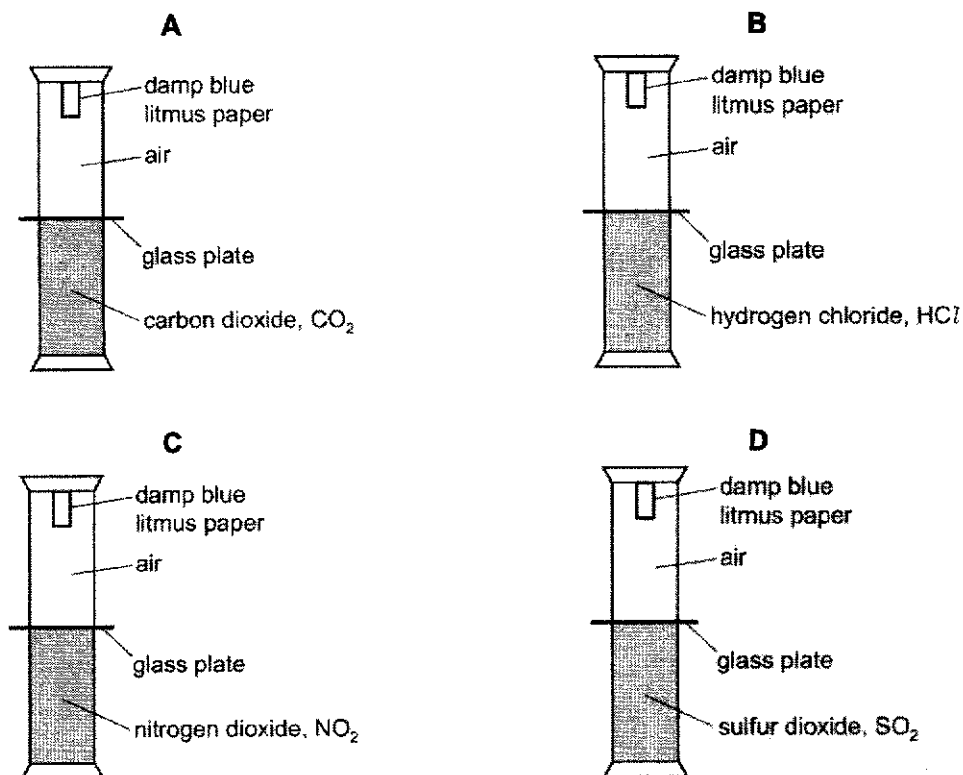

6 The melting points and boiling points of four elements are shown.

element	melting point / °C	boiling point / °C
W	-183	-89
X	-78	-33
Y	-7	59
Z	44	280

In which elements are the particles far apart at 0 °C?

- A W and X B X and Y C X and Z D Y and Z

7 In which species are the numbers of protons, neutrons and electrons all different?

- A ${}^{27}_{13}\text{Al}$ B ${}^{35}_{17}\text{Cl}^-$ C ${}^{32}_{16}\text{S}^{2-}$ D ${}^{39}_{19}\text{K}^+$

- 8 Which molecule has an equal number of valence electrons involved in bonding and not involved in bonding?
- A CH₄ B H₂O C NH₃ D O₂
- 9 Which statement explains why sodium chloride, NaCl, has a lower melting point than magnesium oxide, MgO?
- A Sodium chloride has a simple molecular structure while magnesium oxide has a giant ionic structure.
- B Sodium is more reactive than magnesium.
- C The attraction between Na⁺ and Cl⁻ is weaker than that between Mg²⁺ and O²⁻.
- D The particles in sodium chloride are more closely packed than in magnesium oxide.
- 10 In the structure of solid SiO₂,
- each silicon atom is bonded to x oxygen atoms
 - each oxygen atom is bonded to y silicon atoms
 - the bonding is z.

What is the correct combination of x, y and z in these statements?

	x	y	z
A	2	1	covalent
B	2	1	ionic
C	4	2	covalent
D	4	2	ionic

- 11 Which statement is correct?
- A 1.00 mol of zinc chloride contains 1.20×10^{24} ions.
- B 2.00 mol of sodium nitrate contains 1.20×10^{24} ions.
- C 24.0 dm³ of chlorine gas, measured at room temperature and pressure, contains 1.20×10^{24} atoms.
- D 48.0 dm³ of hydrogen gas, measured at room temperature and pressure, contains 1.20×10^{24} atoms.

- 12 Calcium oxide and magnesium sulfide each reacts with acid.

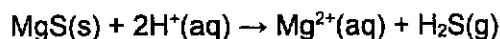
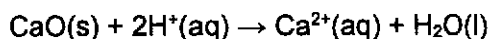

A mixture of these two compounds, X, reacts with exactly 0.125 mol of dilute hydrochloric acid.

The amount of hydrogen sulfide formed is 0.0250 mol.

What is the mass of calcium oxide in mixture X?

- A** 2.1 g **B** 2.8 g **C** 4.2 g **D** 5.6 g

- 13 The formula of an oxide of element Y is Y_2O_5 .

5.4 g of Y_2O_5 contains 1.4 g of Y.

How many moles of Y does 1.4 g of the element contain?

- A** $\frac{1.4}{16} \times \frac{2}{5}$ **B** $\frac{1.4}{16} \times \frac{5}{2}$ **C** $\frac{4.0}{16} \times \frac{2}{5}$ **D** $\frac{4.0}{16} \times \frac{5}{2}$

- 14 Which statements about hydrogen–oxygen fuel cells are correct?

- 1 A hydrogen-oxygen fuel cell is used to generate electricity.
- 2 Hydrogen is extracted from clean, dry air.
- 3 The waste product in a hydrogen-oxygen fuel cell is water.

- A** 1 only **B** 1 and 2 only **C** 1 and 3 only **D** 2 and 3 only

- 15 Aqueous copper(II) sulfate is electrolysed using copper electrodes.

Which row correctly describes what happens?

	colour of electrolyte	mass of anode	mass of cathode
A	becomes colourless	decreases	decreases
B	becomes colourless	remains the same	increases
C	remains blue	remains the same	decreases
D	remains blue	decreases	increases

- 16 Hydrogen reacts with iodine to form hydrogen iodide. The equation for the reaction and enthalpy change are shown.



What can be deduced from this information?

- A The energy absorbed in forming bonds is greater than the energy released in breaking bonds.
- B The energy absorbed in forming bonds is less than the energy released in breaking bonds.
- C The energy released in forming bonds is greater than the energy absorbed in breaking bonds.
- D The energy released in forming bonds is less than the energy absorbed in breaking bonds.
- 17 Under certain conditions, nitrogen reacts with oxygen to form N_2O .

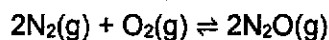

The energy profile diagram is shown.

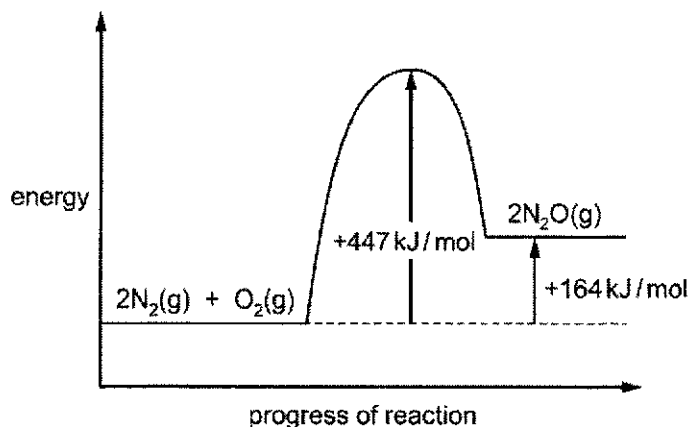

What is the activation energy of the **reverse** reaction?

- A -447 kJ/mol
- B -283 kJ/mol
- C $+164 \text{ kJ/mol}$
- D $+283 \text{ kJ/mol}$

- 18 During the Contact process, sulfuric acid, H_2SO_4 , is produced from sulfur in a series of stages. The sulfur compound produced in each stage is shown.

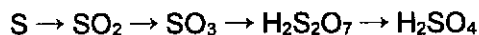

Which statement correctly describes these stages?

- A All stages involve oxidation and the highest oxidation state of sulfur is +12.
 B Only three of the stages involve oxidation and the highest oxidation state of sulfur is +6.
 C Only three of the stages involve oxidation and the highest oxidation state of sulfur is +12.
 D Only two of the stages involve oxidation and the highest oxidation state of sulfur is +6.
- 19 The decomposition of hydrogen peroxide in the presence of MnO_2 is shown.

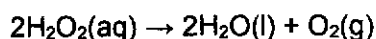

The volume of gas collected when 0.2 g of MnO_2 is added to two different hydrogen peroxide solutions at 20 °C is shown on the graph as curves X and Y.

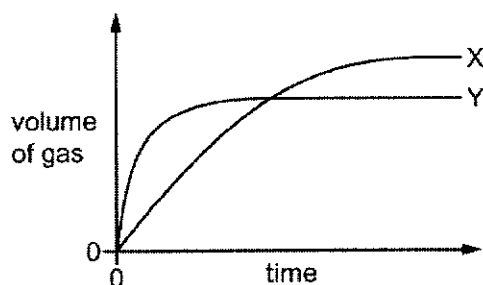

Which row shows the conditions that will result in curves X and Y?

	curve X			curve Y		
	volume of $\text{H}_2\text{O}_2 / \text{cm}^3$	concentration of H_2O_2 in mol/dm^3	form of MnO_2	volume of $\text{H}_2\text{O}_2 / \text{cm}^3$	concentration of H_2O_2 in mol/dm^3	form of MnO_2
A	50	0.1	lumps	50	0.2	powder
B	25	0.2	powder	25	0.1	lumps
C	50	0.1	lumps	20	0.2	powder
D	20	0.2	powder	40	0.1	lumps

- 20 An excess of magnesium ribbon is added to dilute hydrochloric acid and the volume of gas produced is measured as the reaction proceeds. The reaction is exothermic.

The results are shown.

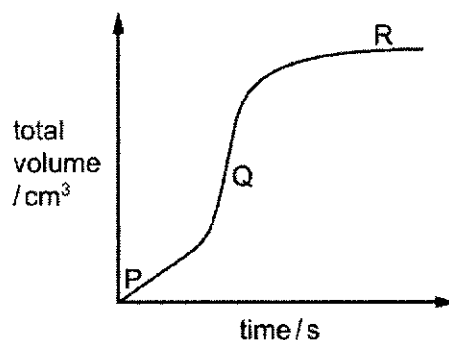

Which row explains the changes in the rate of reaction between points P and Q and between points Q and R?

	between points P and Q	between points Q and R
A	reaction temperature is increasing	concentration of acid is decreasing
B	reaction temperature is increasing	magnesium has been used up
C	surface area of magnesium is decreasing	concentration of acid is decreasing
D	surface area of magnesium is decreasing	magnesium has been used up

- 21 Samples of $\text{HCl}(\text{aq})$ and $\text{HNO}_3(\text{aq})$ are tested using Universal Indicator.

The sample of $\text{HCl}(\text{aq})$ has a pH of 4 and the sample of $\text{HNO}_3(\text{aq})$ has a pH of 2.

Which statement explains why the samples of $\text{HCl}(\text{aq})$ and $\text{HNO}_3(\text{aq})$ have different pH values?

- A** $\text{HCl}(\text{aq})$ is a weak acid and $\text{HNO}_3(\text{aq})$ is a strong acid.
B $\text{HNO}_3(\text{aq})$ has a higher relative molecular mass than $\text{HCl}(\text{aq})$.
C The sample of $\text{HCl}(\text{aq})$ has ionised more than the sample of $\text{HNO}_3(\text{aq})$.
D The sample of $\text{HNO}_3(\text{aq})$ is more concentrated than the sample of $\text{HCl}(\text{aq})$.

[Turn Over

22 Hydrazine has the formula $\text{H}_2\text{N}-\text{NH}_2$. It has similar properties to ammonia.

Which statements about hydrazine is correct?

- 1 It dissolves in water to form hydroxide ions.
- 2 It forms salts with alkalis.
- 3 It reacts with hydrogen chloride to form $\text{C}_2\text{H}_5\text{N}-\text{NH}_3\text{Cl}$.

A 1 only **B** 1 and 2 only **C** 1 and 3 only **D** 2 and 3 only

23 Which method gives the best yield of lead(II) sulfate?

- A** Add excess dilute hydrochloric acid to lead(II) oxide, followed by dilute sulfuric acid.
- B** Add excess dilute nitric acid to lead(II) carbonate, followed by dilute sulfuric acid.
- C** Add excess water to lead(II) carbonate, followed by dilute sulfuric acid.
- D** Add excess water to lead(II) oxide, followed by dilute sulfuric acid.

24 Copper(II) nitrate is made by reacting an excess of a powdered solid with an aqueous solution.

The mixture is filtered and the filtrate is crystallised.

Which row identifies a solid and an aqueous solution that can be used to make a pure sample of copper(II) nitrate?

	solid in excess	aqueous solution
A	copper	dilute nitric acid
B	copper	silver nitrate
C	copper(II) chloride	dilute nitric acid
D	copper(II) oxide	silver nitrate

25 Ammonia is produced by the Haber process.

Which statement is **not** correct?

- A** Iron provides an alternative pathway with a lower activation energy.
- B** The nitrogen and hydrogen react in a 1:3 ratio by mass.
- C** The nitrogen for the process is obtained from liquid air.
- D** The reaction is reversible.

26 Astatine is below iodine in Group 17 of the Periodic Table.

Which row describes the properties of astatine?

	state at room temperature	reactivity
A	gas	does not displace chlorine, bromine and iodine
B	gas	displaces iodine but does not displace chlorine or bromine
C	solid	does not displace chlorine, bromine and iodine
D	solid	displaces iodine but does not displace chlorine or bromine

27 The properties of the element cobalt, Co, can be predicted from its position in the Periodic Table.

Which row describes the properties of cobalt?

	conducts electricity when solid	has low density	has variable oxidation states	forms coloured compounds
A	✓	✓	✓	×
B	✓	✓	×	✓
C	✓	×	✓	✓
D	×	✓	✓	✓

28 Three elements, X, Y and Z have consecutive, increasing proton (atomic) numbers.

If element X is a noble gas, what will be the chemical symbol for the ions of element Z in its compounds?

- A** Z^- **B** Z^{2-} **C** Z^+ **D** Z^{2+}

29 Metal Q is between iron and copper in the reactivity series.

Which methods could be used to extract metal Q?

- 1 electrolysis of the molten metal oxide
- 2 heating the metal oxide with carbon
- 3 heating the metal oxide with copper

- A** 1 and 2 only **B** 1 only **C** 2 and 3 only **D** 2 only

[Turn Over

- 30 A small piece of metal is added to a large beaker of water.

A vigorous reaction occurs.

When the reaction stops, a few drops of Universal Indicator are added to the solution.

What is the metal and the colour of the solution after the Universal Indicator is added?

	metal	colour of solution
A	sodium	purple
B	sodium	red
C	zinc	purple
D	zinc	red

- 31 The diagram shows the structure of bronze.

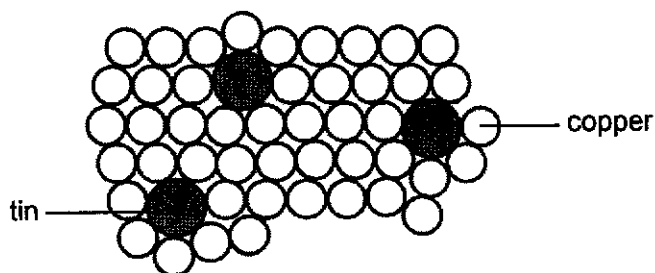

Why is bronze harder than pure copper?

- A** The tin atoms form strong ionic bonds with copper atoms.
B The tin atoms prevent the layers of copper atoms from sliding over each other easily.
C The tin atoms prevent the 'sea of electrons' from moving freely.
D The tin atoms strengthen the metallic bonds in bronze.
- 32 What is the harmful effect of chlorofluorocarbons, sulfur dioxide and carbon monoxide?

	chlorofluorocarbons	sulfur dioxide	carbon monoxide
A	depletion of the ozone layer	acid rain	toxic
B	depletion of the ozone layer	respiratory problems	global warming
C	global warming	acid rain	depletion of the ozone layer
D	respiratory problems	global warming	toxic

- 33 The diagram shows the fractional distillation column used to separate crude oil into fractions.

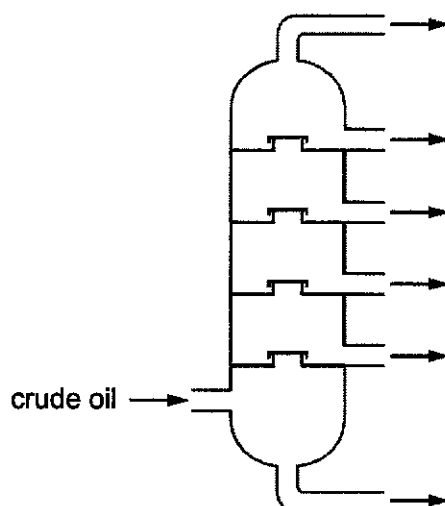

Which statement about the fractional distillation of crude oil is correct?

- A Each fraction contains one compound only.
- B The fraction collected at the bottom of the column has the lowest boiling point.
- C The fraction collected at the top of the column has the smallest molecules.
- D The higher up the column, the higher the temperature.
- 34 Which pair contains a substance that is **not** made during the reaction of CH_4 with excess chlorine in the presence of ultraviolet light?
- A CH_3Cl , CCl_4
- B CH_2Cl_2 , HCl
- C CH_2Cl_2 , CHCl_3
- D CHCl_3 , H_2
- 35 The general formula of the alkanes is $\text{C}_n\text{H}_{2n+2}$.

Which physical property **decreases** as n increases?

- A boiling point
- B flammability
- C melting point
- D viscosity

- 36 The structures of two isomers, with the molecular formula, C_4H_8 , are given below.

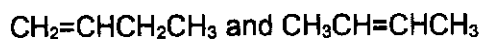

How many of the statements about these two isomers are correct?

- Complete combustion of 1 mole of each isomer produces equal number of moles of carbon dioxide and water.
- Both produce the same molecule when reacted with hydrogen.
- Both produce the same molecule when reacted with steam.
- When polymerised, the same polymer is produced.

A 1 B 2 C 3 D 4

- 37 An aqueous solution contains 7.4 g of a carboxylic acid, Q.

When excess magnesium is added to this solution, 1200 cm^3 of gas is produced at room temperature and pressure.

What is Q?

- A CH_3COOH
B C_2H_5COOH
C C_3H_7COOH
D $HCOOH$

- 38 Butanol and methanoic acid react to form an ester, R.

What is the formula of R?

- A $CH_3CH_2CH_2CO_2CH_3$
B $CH_3CH_2CO_2CH_2CH_3$
C $CH_3CO_2CH_2CH_2CH_2CH_3$
D $HCO_2CH_2CH_2CH_2CH_3$

- 39 Part of the structures of two different polymers, X and Y, are shown.

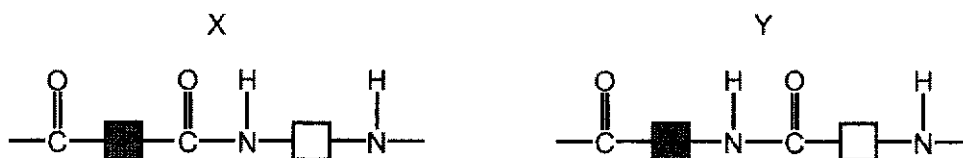

Which row about the monomers and the linkages between the monomers in polymers X and Y is correct?

	monomers in X and Y	linkages in X and Y
A	different	different
B	different	same
C	same	different
D	same	same

- 40 Which are methods of recycling plastics?

- 1 cracking of plastic waste
- 2 hydrolysis of polyesters
- 3 melting poly(ethene) waste into pellets

- A** 1, 2 and 3 **B** 1 and 2 only **C** 1 and 3 only **D** 2 and 3 only

- End of Paper -

[Turn Over

16
The Periodic Table of Elements

		Group																													
1	2	3	4	5	6	7	8	9	10	11	12	13	14	15	16	17	18														
		<div style="border: 1px solid black; padding: 5px; width: fit-content; margin: 0 auto;"> <p>1 H hydrogen 1</p> </div>																													
		<div style="border: 1px solid black; padding: 5px; width: fit-content; margin: 0 auto;"> <p>Key</p> <p>proton (atomic) number</p> <p>atomic symbol</p> <p>name</p> <p>relative atomic mass</p> </div>																													
3 Li lithium 7	4 Be beryllium 9	21 Sc scandium 45	22 Ti titanium 48	23 V vanadium 51	24 Cr chromium 52	25 Mn manganese 55	26 Fe iron 56	27 Co cobalt 59	28 Ni nickel 59	29 Cu copper 64	30 Zn zinc 65	5 B boron 11	6 C carbon 12	7 N nitrogen 14	8 O oxygen 16	9 F fluorine 19	10 Ne neon 20														
11 Na sodium 23	12 Mg magnesium 24	39 Y yttrium 89	40 Zr zirconium 91	41 Nb niobium 93	42 Mo molybdenum 96	43 Tc technetium -	44 Ru ruthenium 101	45 Rh rhodium 103	46 Pd palladium 106	47 Ag silver 108	48 Cd cadmium 112	13 Al aluminium 27	14 Si silicon 28	15 P phosphorus 31	16 S sulfur 32	17 Cl chlorine 35.5	18 Ar argon 40														
19 K potassium 39	20 Ca calcium 40	57-71 lanthanoids	72 Hf hafnium 178	73 Ta tantalum 181	74 W tungsten 184	75 Re rhenium 186	76 Os osmium 190	77 Ir iridium 192	78 Pt platinum 195	79 Au gold 197	80 Hg mercury 201	31 Ga gallium 70	32 Ge germanium 73	33 As arsenic 75	34 Se selenium 79	35 Br bromine 80	36 Kr krypton 84														
37 Rb rubidium 85	38 Sr strontium 88	89-103 actinoids	88 Ba barium 137	89 La lanthanum 139	90 Ce cerium 140	91 Pr praseodymium 141	92 Nd neodymium 144	93 Pm promethium -	94 Pu plutonium 244	95 Am americium 243	96 Cm curium 247	81 Tl thallium 204	82 Pb lead 207	83 Bi bismuth 209	84 Po polonium -	85 At astatine -	86 Rn radon -														
55 Cs caesium 133	56 Ba barium 137	87 Fr francium -	88 Ra radium -	57 La lanthanum 139	58 Ce cerium 140	59 Pr praseodymium 141	60 Nd neodymium 144	61 Pm promethium -	62 Sm samarium 150	63 Eu europium 152	64 Gd gadolinium 157	65 Tb terbium 159	66 Dy dysprosium 163	67 Ho holmium 165	68 Er erbium 167	69 Tm thulium 169	70 Yb ytterbium 173	71 Lu lutetium 175													
87 Fr francium -	88 Ra radium -	89 Ac actinium -	90 Th thorium 232	91 Pa protactinium 231	92 U uranium 238	93 Np neptunium -	94 Pu plutonium -	95 Am americium -	96 Cm curium -	97 Bk berkelium -	98 Cf californium -	99 Es einsteinium -	100 Fm fermium -	101 Md mendelevium -	102 No nobelium -	103 Lr lawrencium -	104 Rf rutherfordium -	105 Db dubnium -	106 Sg seaborgium -	107 Bh bohrium -	108 Hs hassium -	109 Mt meitnerium -	110 Ds darmstadtium -	111 Rg roentgenium -	112 Cn copernicium -	113 Nh nihonium -	114 Fl flerovium -	115 Mc moscovium -	116 Lv livermorium -	117 Ts tennessine -	118 Og oganeson -

lanthanoids	57 La lanthanum 139	58 Ce cerium 140	59 Pr praseodymium 141	60 Nd neodymium 144	61 Pm promethium -	62 Sm samarium 150	63 Eu europium 152	64 Gd gadolinium 157	65 Tb terbium 159	66 Dy dysprosium 163	67 Ho holmium 165	68 Er erbium 167	69 Tm thulium 169	70 Yb ytterbium 173	71 Lu lutetium 175
actinoids	89 Ac actinium -	90 Th thorium 232	91 Pa protactinium 231	92 U uranium 238	93 Np neptunium -	94 Pu plutonium -	95 Am americium -	96 Cm curium -	97 Bk berkelium -	98 Cf californium -	99 Es einsteinium -	100 Fm fermium -	101 Md mendelevium -	102 No nobelium -	103 Lr lawrencium -

The volume of one mole of any gas is 24 dm³ at room temperature and pressure (r.t.p.).
The Avogadro constant, $L = 6.02 \times 10^{23} \text{ mol}^{-1}$

[Turn Over

Name:		Index Number:		Class:	
--------------	--	----------------------	--	---------------	--



CATHOLIC HIGH SCHOOL
Preliminary Examination
Secondary 4 'O' Level Programme

A

CHEMISTRY

Paper 2

6092/02

20 August 2024
 1 hour 45 minutes

Candidates answer on the Question Paper.
 No Additional Materials are required.

READ THESE INSTRUCTIONS FIRST

Write your name, index number and class on all the work you hand in.
 Write in dark blue or black pen.
 You may use an HB pencil for any diagrams or graphs.
 Do not use staples, paper clips, glue or correction fluid.

Section A

Answer all questions.
 Write your answers in the spaces provided.

The number of marks is given in brackets [] at the end of each question or part question.

The use of an approved scientific calculator is expected, where appropriate.

A maximum of 1 mark will be deducted from your total mark for failure to show your working with clear statements in calculations and misuse of units and/or significant figures, i.e. failure to quote units where necessary, the inclusion of units in quantities defined as ratios or quoting answers to an inappropriate number of significant figures.

For examiner's use only:

Section A	/ 70
working / units / significant figures	<input type="checkbox"/> -1 if checked

This document consists of 18 printed pages and 2 blank pages.

[Turn Over

Section A

Answer all questions.

1 Some chemical and word equations, A to J, are shown.

A glucose \rightarrow ethanol + carbon dioxideB $\text{HNO}_3 + \text{NaOH} \rightarrow \text{NaNO}_3 + \text{H}_2\text{O}$ C water \rightarrow hydrogen + oxygenD $\text{C}_{12}\text{H}_{26} \rightarrow \text{C}_8\text{H}_{18} + \text{C}_4\text{H}_8$ E ethanoic acid + ethanol \rightleftharpoons ethyl ethanoate + waterF ethene + steam \rightarrow ethanolG $2\text{CH}_4 + 3\text{O}_2 \rightarrow 2\text{CO} + 4\text{H}_2\text{O}$ H $\text{C}_2\text{H}_6 + \text{Cl}_2 \rightarrow \text{C}_2\text{H}_5\text{Cl} + \text{HCl}$ I $\text{C}_6\text{H}_{12}\text{O}_6 + 6\text{O}_2 \rightarrow 6\text{CO}_2 + 6\text{H}_2\text{O}$ J $2\text{HCl} + \text{Pb}(\text{NO}_3)_2 \rightarrow \text{PbCl}_2 + 2\text{HNO}_3$

Use the equations to answer the questions that follow.

Each equation may be used once, more than once, or not at all.

Write down the letter, A to J, for the equation which represents:

(a) cracking

..... [1]

(b) neutralisation

..... [1]

(c) precipitation

..... [1]

(d) respiration

..... [1]

(e) substitution

..... [1]

[Total: 5]

- 2 Table 2.1 shows the structural formula of monomers, structure of repeat unit of polymers and type of reaction used to form polymers **A** and **B**.

Complete the table by filling in the missing information.

Table 2.1

polymer	structural formula of monomer(s)	structure of repeat unit of polymer	type of reaction used to form polymer
A	$\text{CH}_3\text{CH}=\text{CH}_2$	
B	$\text{HOOC}-(\text{CH}_2)_4-\text{COOH}$ $\text{H}_2\text{N}-(\text{CH}_2)_6-\text{NH}_2$	

[4]

[Total: 4]

[Turn Over

- 3 Car engines are adjusted to work in a particular ratio of air to fuel.

The amount of air that is mixed with the fuel affects the temperature of the engine, the amount of pollutant gases that form and how efficiently the catalytic converter works.

Table 3.1 shows some information about lean burn engines compared to normal car engines.

Table 3.1

type of engine	air to fuel ratio	operating temperature	concentration of carbon monoxide in exhaust gases	concentration of nitrogen oxides in exhaust gases
normal	lower	higher	higher	higher
lean burn	higher	lower	lower	lower

- (a) Suggest why lean burn engines produce a lower concentration of nitrogen oxides.

.....
 [1]

- (b) Suggest why lean burn engines produce a lower concentration of carbon monoxide.

.....
 [1]

- (c) Nitrogen oxides are removed from car exhaust emissions by catalytic converters.

In a catalytic converter, nitrogen monoxide reacts with carbon monoxide.

- (i) Write a chemical equation for this reaction.

..... [1]

- (ii) Without a catalyst, the reaction between carbon monoxide and nitrogen monoxide is slow.

Use ideas about energy and collisions to explain why carbon monoxide and nitrogen monoxide react faster in a catalytic converter.

.....

.....

.....

.....

.....

.....

.....

..... [3]

[Total: 6]

[Turn Over

4 This question is about making salts.

(a) Copper(II) nitrate can be prepared by reacting excess copper(II) oxide with dilute nitric acid.

(i) Describe how pure, dry crystals of copper(II) nitrate is obtained after excess copper(II) oxide is added to dilute nitric acid.

.....
.....
.....
..... [3]

(ii) Explain why copper cannot be used to prepare copper(II) nitrate.

.....
..... [1]

(b) Sodium sulfate is used in the manufacture of laundry detergents.

(i) State the formulae, with state symbols, of the reagents used to prepare sodium sulfate.

reagent 1

reagent 2 [2]

(ii) Explain why the method described in (a) **cannot** be used to prepare pure sodium sulfate.

.....
..... [1]

[Total: 7]

BLANK PAGE

[Turn Over

- 5 (a) Fig. 5.1 shows an experiment in which steam was passed over 5.6 g of hot iron filings. The products of the reaction are iron oxide, Fe_3O_4 , and a gas.

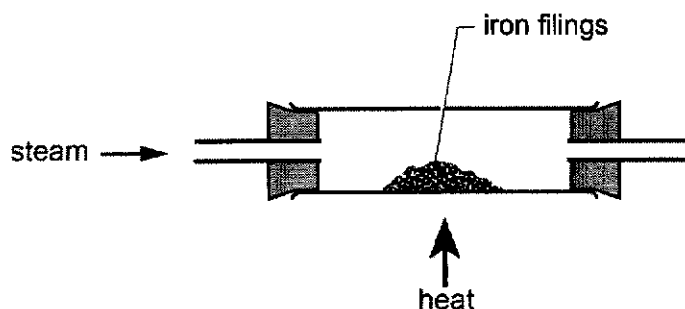

Fig. 5.1

- (i) State the gas produced and describe a test to identify the gas.

.....

 [2]

- (ii) Describe and explain the change in mass of the solid during the experiment.

.....

 [2]

- (iii) The experiment is repeated using the same amount of magnesium and again using the same amount of lead.

Predict the order of change in mass of the solid for iron, magnesium and lead, starting with the metal with the least change in mass.

Explain your reasoning in words or by means of a calculation.

order of change in mass

reasoning

..... [3]

(b) The Statue of Liberty in New York is made from an iron frame covered with copper plates.

In 2004, work had to be carried out to stop the iron frame from rusting.

The iron frame was rusting much faster than normal where it was in contact with the copper.

Explain why copper in contact with iron causes the iron to rust faster than normal.

.....
.....
.....
..... [2]

[Total: 9]

[Turn Over

- 6 Ionisation is the process in which electrons are removed from atoms and cations. The energy required for this process is called ionisation energy.

The equations show the removal of electrons from Na atoms and Na⁺ ions, with the energy changes involved.

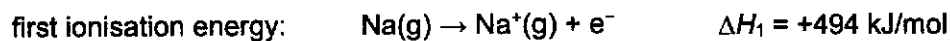

- (a) (i) Complete the diagram of an atom of sodium to show:

- the names and numbers of each particle in the nucleus
- the arrangement of the electrons.

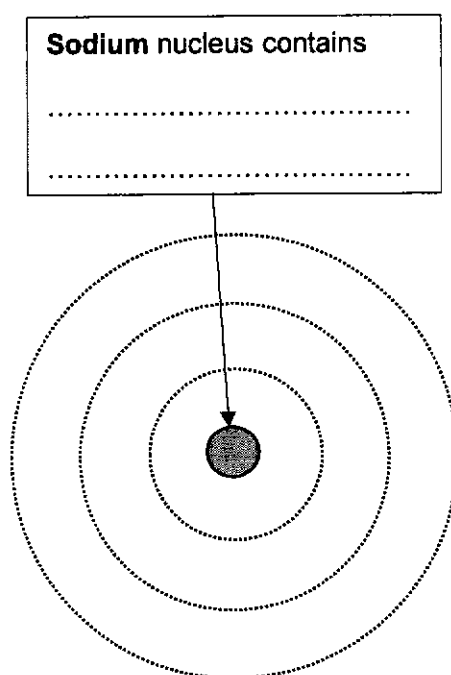

[1]

- (ii) Hence, explain why the value of ΔH_2 is much higher than that of ΔH_1 .

.....

..... [1]

- (b) Sodium is a Group 1 element.

Describe the trend in reactivity and melting point down Group 1.

..... [1]

The energy change when electrons are gained by atoms and anions is called electron affinity.

The equations show the gaining of electrons by O atoms and O⁻ ions, with the energy changes involved.

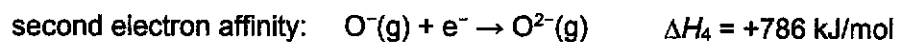
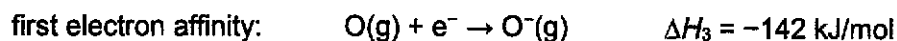

(c) Suggest a reason to explain why ΔH_4 is positive.

.....
 [1]

(d) Complete and label the energy level diagrams to show the products and energy changes for the first ionisation energy of sodium and first electron affinity of oxygen.

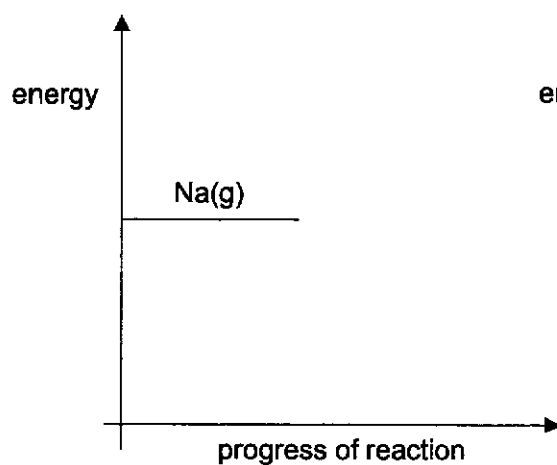

first ionisation energy of sodium

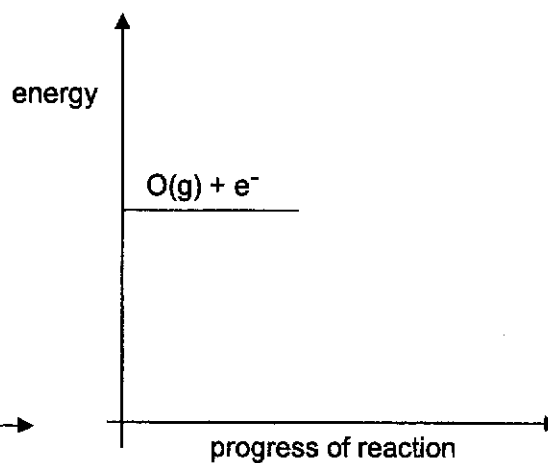

first electron affinity of oxygen

[3]

[Total: 7]

[Turn Over

- 7 Fig. 7.1 shows the electrolysis of concentrated and dilute aqueous sodium chloride using graphite electrodes. Gases are produced and collected in each of the test-tubes W, X, Y and Z.

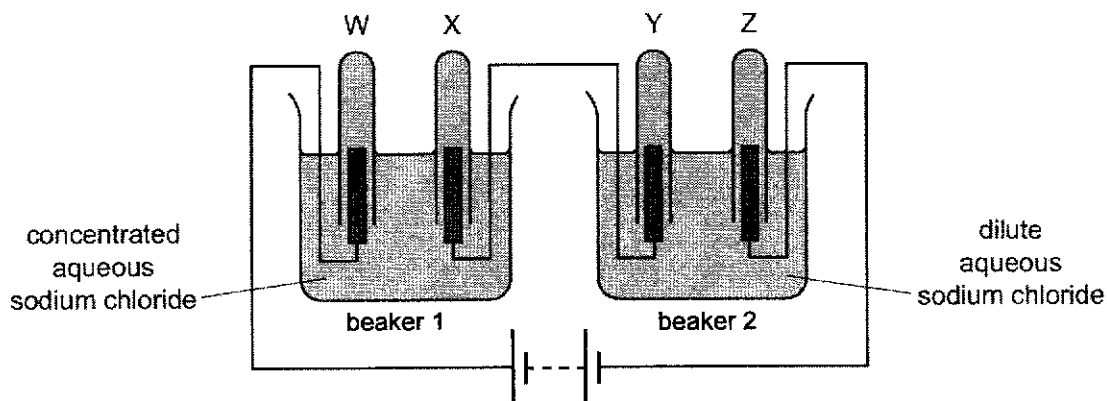

Fig. 7.1

- (a) Describe the differences between what happens when electricity passes through the graphite electrodes compared to what happens when electricity passes through dilute aqueous sodium chloride.

.....

.....

.....

..... [2]

- (b) (i) Identify the gases collected in test-tubes Y and Z.

gas collected in test-tube Y

gas collected in test-tube Z [1]

- (ii) The ratio of the volume of gases collected in test-tubes Y and Z is observed to be 1:2.

Explain this observation.

Your answer should include half-equations for the reaction at each electrode.

.....

.....

.....

.....

.....

..... [4]

- (c) (i) Identify the gases collected in test-tubes W and X.
gas collected in test-tube W
gas collected in test-tube X [1]
- (ii) State the ratio of the volume of gases collected in test-tubes W and X.
..... [1]
- (d) Universal Indicator is added to the solution in beakers 1 and 2 after the electrolysis.
Predict the colour of the Universal Indicator in beakers 1 and 2.
colour in beaker 1
colour in beaker 2
Explain your reasoning.
.....
.....
.....
..... [3]

[Total: 12]

[Turn Over]

8 This question is about elements, from Period 2 and Period 3, and their compounds.

(a) Table 8.1 shows some properties of aluminium fluoride and aluminium chloride.

Table 8.1

compound	melting point / °C	electrical conductivity when molten
aluminium fluoride	1290	good
aluminium chloride	180	poor

(i) Draw a 'dot-and-cross' diagram to show the bonding in aluminium fluoride.

Show outer electrons only.

[2]

(ii) Use ideas about structure and bonding to explain why the properties of aluminium chloride shown in Table 8.1 are unusual.

.....

.....

.....

.....

.....

.....

..... [3]

- (b) Period 2 and Period 3 elements that are diagonal to each other in the Periodic Table have similar physical and chemical properties. These elements have a diagonal relationship.

For example, beryllium and boron are the first elements of Group 2 and Group 13 respectively. Some of their properties do not resemble the properties exhibited by the other elements in their group. Instead, their properties resemble the properties of the second element in the following group.

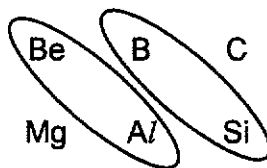

- (i) Beryllium and aluminium have a diagonal relationship.

Suggest **one** difference in the chemical property of beryllium oxide and magnesium oxide.

.....
 [1]

- (ii) Boron and silicon have a diagonal relationship.

Silicon has a giant covalent structure.

Suggest **two** physical properties of boron.

.....
 [2]

[Total: 8]

9 Using chlorine as a disinfectant in swimming pools

Swimming pools need to be disinfected. Disinfectants work by killing bacteria. Originally, chlorine gas, stored in gas cylinders, was added to water in the swimming as a disinfectant.

Chlorine reacts with the water to form chloric(I) acid and hydrochloric acid, as shown in equation 1.

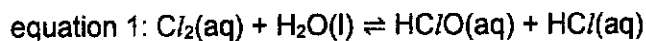

The total amount of chloric(I) acid present in a swimming pool can be found by redox titration.

All the chloric(I) acid present in a sample of water in the swimming pool reacts with an excess of acidified potassium iodide solution, as shown in equation 2. The amount of iodine produced can be found by titration with a known concentration of sodium thiosulfate solution. Equation 3 shows the reaction between sodium thiosulfate and iodine. From the results obtained from this titration, the total amount of chloric(I) acid present in the sample can be found.

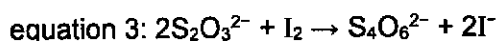
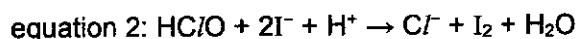

Guidelines on the use of chlorine as disinfectants

Chlorine gas can irritate our eyes and lungs, and inhalation of chlorine in higher concentrations may result in choking sensations, vomiting, chest pain and difficulty in breathing. Instead of adding chlorine gas directly into swimming pools, operators use sodium chlorate(I) solution, NaClO or solid calcium chlorate(I), $\text{Ca}(\text{ClO})_2$, which are safer. Care must also be taken to ensure that chemicals are not illegally disposed of into the sewage system.

Solubility of chlorine

Researchers studying the solubility of chlorine in pure water at different temperatures compiled the data from different sources in Table 9.1.

Table 9.1

Source	Temperature / °C	Solubility of chlorine
A	0	1.46 g per 100 cm ³
B	10	310 cm ³ per 100 cm ³
C	20	0.70 g per 100 cm ³
D	25	6300 mg per 1000 cm ³
E	30	177 cm ³ per 100 cm ³
F	30	0.57 g per 100 cm ³

The units of solubility are converted to mol/dm³ as shown in Table 9.2 .

Table 9.2

Source	Temperature / °C	Solubility of chlorine	Solubility of chlorine in mol/dm ³
A	0	1.46 g per 100 cm ³	0.206
B	10	310 cm ³ per 100 cm ³	0.13
C	20	0.70 g per 100 cm ³	0.099
D	25	6300 mg per 1000 cm ³	0.089
E	30	177 cm ³ per 100 cm ³	
F	30	0.57 g per 100 cm ³	0.080

Problem caused by poor hygiene in swimming pools

Researchers also found out that many people do not shower before entering the swimming pool. Urine and sweat, which contain ammonia, are released into the water in the swimming pool. The ammonia released reacts with chloric(I) acid, HOCl, to form chloramines, NH₂Cl, NHCl₂ and NCl₃.

Fig. 9.1 shows the molar ratio of chloramines formed at different pH values at 25 °C. Trichloramine, NCl₃, causes the water in the swimming pool to smell bad.

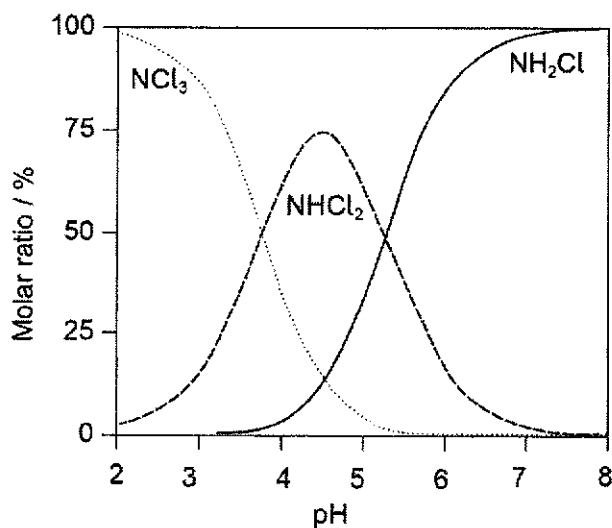

Fig. 9.1

- (a) (i) Use oxidation states to prove that the reaction shown in equation 3 is a redox reaction.

.....
.....
..... [2]

- (ii) A swimming pool is suspected to contain excessive amounts of chloric(I) acid. Hence, a sample of the water in the swimming pool was tested to measure the amount of chloric(I) acid it contained. An excess of acidified potassium iodide solution was added. The resulting mixture reacted with 24.70 cm^3 of 0.100 mol/dm^3 sodium thiosulfate.

Calculate the amount, in moles, of chloric(I) acid present in this sample of the water in the swimming pool

[2]

- (b) Company X claims that using chlorine gas is the most cost-effective method of disinfection compared to sodium chlorate(I) solution, NaClO , or solid calcium chlorate(I), Ca(ClO)_2 because it has the highest chlorine content by mass.

Do you agree with the company's claim?

Explain your answer by means of a calculation.

[2]

- (c) (i) Apart from the use of different units, identify another problem in comparing the data from different sources in Table 9.1.

.....
 [1]

- (ii) Calculate the solubility of chlorine, in mol/dm³, for source E.

Assume the density of chlorine is 2.86 g/dm³ at 30 °C.

[2]

- (iii) Some indoor swimming pools are heated as the heat from the water relaxes muscles.

Suggest **one** reason why operating an unheated swimming pool causes **less** environmental problems.

.....
 [1]

- (d) (i) Ammonia and chloric(I) acid react to form dichloramine and water.

Write a chemical equation for the reaction.

..... [1]

- (ii) State **one** condition needed to prevent the bad smell of the swimming pool caused by trichloramine.

.....
 [1]

[Total: 12]

[Turn Over

BLANK PAGE

Name:		Index Number:		Class:	
--------------	--	----------------------	--	---------------	--



CATHOLIC HIGH SCHOOL
Preliminary Examination
Secondary 4 'O' Level Programme

B

CHEMISTRY

Paper 2

6092/02

20 August 2024
 1 hour 45 minutes

Candidates answer on the Question Paper.
 No Additional Materials are required.

READ THESE INSTRUCTIONS FIRST

Write your name, index number and class on all the work you hand in.
 Write in dark blue or black pen.
 You may use an HB pencil for any diagrams or graphs.
 Do not use staples, paper clips, glue or correction fluid.

Section B

Answer **one** question.
 Write your answers in the spaces provided.

The number of marks is given in brackets [] at the end of each question or part question.
 A copy of the Periodic Table is printed on page 6.

The use of an approved scientific calculator is expected, where appropriate.

For examiner's use only:

Section B	/ 10
------------------	-------------

This document consists of 6 printed pages.

[Turn Over

(c) Compound **A**, $C_3H_4O_2$, reacts with acidified potassium manganate(VII) to form malonic acid.

(i) Name the type of reaction compound **A** undergoes to form malonic acid.

..... [1]

(ii) Draw the displayed formula of compound **A**.

[1]

(iii) Name the homologous series that contains the functional group in compound **A**.

..... [1]

(iv) Using a different reagent, compound **A** forms compound **B**. The structure of compound **B** is shown in Fig. 10.2.

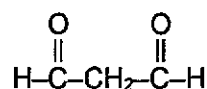

Fig. 10.2

Are malonic acid and compound **B** isomers? Explain your reasoning.

.....
 [1]

[Total: 10]

[Turn Over

- 11 (a) Cyclohexane is a saturated hydrocarbon while hexene is an unsaturated hydrocarbon. Fig. 11.1 shows the structures of cyclohexane and hexene.

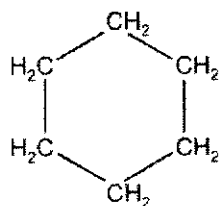

cyclohexane

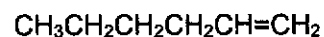

hexene

Fig. 11.1

- (i) Are cyclohexane and hexene isomers? Explain your reasoning.

.....
 [1]

- (ii) Compare the properties of cyclohexane and hexene.

Your answer should include a discussion of the similarities and differences in their

- combustion reaction
- reaction with aqueous bromine.

Include equations and observations, where necessary, for any reactions you discuss.

.....

 [5]

- (b) Vegetable oils react with methanol to produce a biofuel. Fig. 11.2 shows the structures of some of the molecules involved in the reaction.

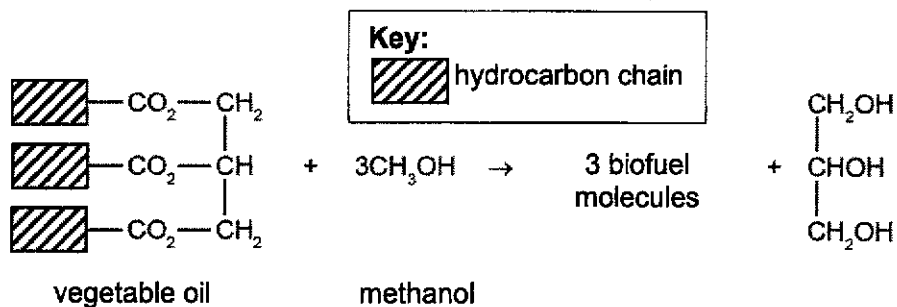

Fig. 11.2

- (i) Name the homologous series that contains the functional group in vegetable oil.
 [1]

- (ii) One molecule of vegetable oil reacts to form three molecules of biofuel.
 The biofuel and vegetable oil contain the same functional group.

Suggest the displayed formula of one molecule of biofuel.

Use to represent the hydrocarbon chain.

[1]

- (iii) Explain why biofuel is considered a renewable and more environmentally sustainable energy source compared to diesel obtained from crude oil.

.....

 [2]

[Total: 10]

- End of Paper -

[Turn Over

Turn Over

2024 Sec 4 Preliminary Examination Mark Scheme

Paper 1

1	2	3	4	5	6	7	8	9	10
B	A	D	A	B	A	D	B	C	C
11	12	13	14	15	16	17	18	19	20
C	A	C	C	D	D	D	D	C	A
21	22	23	24	25	26	27	28	29	30
D	C	B	B	B	C	C	D	A	A
31	32	33	34	35	36	37	38	39	40
B	A	C	D	B	B	B	D	B	A

Paper 2 Section A

Qn	Answers	Mark	Guidance
1a	D	1	R: multiple answers
1b	B	1	
1c	J	1	
1d	I	1	
1e	H	1	
2	<p>Polymer A Structure of repeat unit</p> $\begin{array}{c} \text{CH}_3 \quad \text{H} \\ \quad \\ -\text{C} - \text{C}- \\ \quad \\ \text{H} \quad \text{H} \end{array} ;$ <p>Type of reaction : <u>addition</u> ;</p> <p>Polymer B Structure of repeat unit</p> $\begin{array}{c} \text{O} \quad \quad \quad \text{O} \\ \quad \quad \quad \\ -\text{C} - (\text{CH}_2)_4 - \text{C} - \text{N} - (\text{CH}_2)_6 - \text{N} - \\ \quad \quad \quad \\ \text{H} \quad \quad \quad \text{H} \end{array} ;$ <p>Type of reaction : <u>condensation</u> ;</p>	4	R: structure of polymer

Qn	Answers	Mark	Guidance
3a	At lower temperatures, less/slower reaction between nitrogen and oxygen ;	1	OWTTE
3b	More oxygen + less incomplete combustion / more complete combustion ;	1	
3ci	$2\text{CO} + 2\text{NO} \rightarrow 2\text{CO}_2 + \text{N}_2$	1	
3cii	catalysts provide an alternative reaction pathway with lower activation energy ; greater proportion of molecules with energy greater than or equal to activation energy ; greater frequency of effective collisions ;	3	A: number & particles
4ai	filter out excess solid / CuO / to obtain filtrate ; heat filtrate to saturation + leave to cool (for crystals to form) ; filter out crystals + wash crystals with little cold distilled water + dry between pieces of filter paper ;	3	
4aii	Copper is unreactive / does not react with dilute acids	1	
4bi	NaOH(aq) / Na ₂ CO ₃ (aq) ; H ₂ SO ₄ (aq) ;	2	
4bii	solid Na ₂ O is soluble in water + not possible to separate excess reagent from Na ₂ SO ₄ (by filtration) ;	1	OWTTE
5ai	Hydrogen / H ₂ ; Place a <u>lighted splint</u> at the mouth of test-tube + gas extinguishes a lighted splint with a ' <u>pop</u> ' sound ;	2	
5aii	Mass of solid increases ; Iron gains oxygen to form iron oxide ;		OWTTE
5aiii	(order of change in mass) Pb, Mg, Fe ; Pb does not react with steam + no change in mass ; 1 mole of Mg gains 16 g while 1 mole of Fe gains 21.3 g ;	3	OWTTE R: no mention of numbers

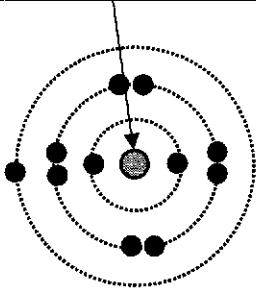
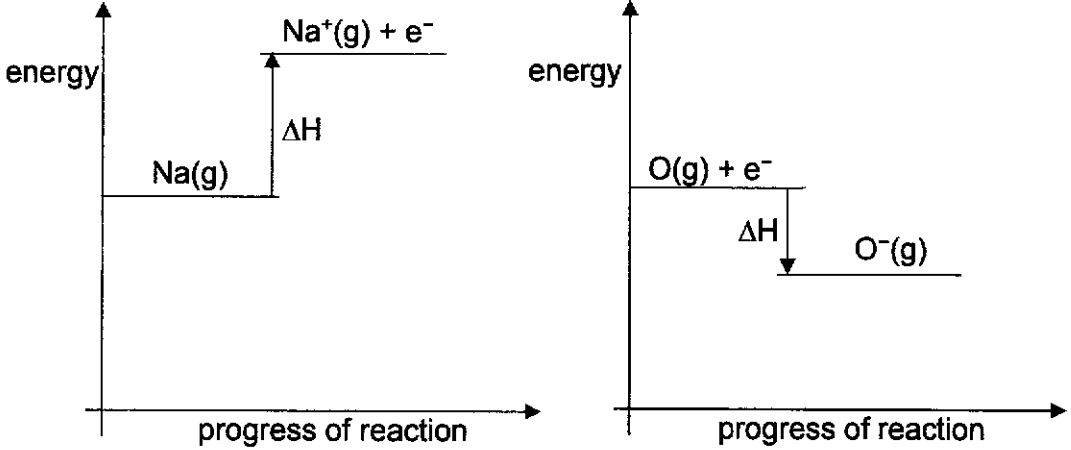
Qn	Answers	Mark	Guidance
5b	Iron is more reactive than copper ; Iron loses electrons / oxidises more readily + provides <u>sacrificial protection</u> to copper ;	2	ORA
6ai	<div style="border: 1px solid black; padding: 5px; width: fit-content; margin-bottom: 10px;"> Sodium nucleus contains 11 protons + 12 neutrons </div> 	1	A: crosses to represent electrons
6aii	The electron removed for ΔH_2 is from a shell which is closer to the nucleus ;	1	R: Na attained noble gas electronic configuration
6b	Reactivity increases + melting point decreases down Group 1 ;	1	
6c	Energy is absorbed to overcome repulsion between like charges / negatively-charged ions and electrons ;	1	
6d	 <p style="text-align: center;"> first ionisation energy of sodium first electron affinity of oxygen </p> <p>correct diagram for first ionisation energy of sodium – 1 m correct diagram for first electron affinity of oxygen – 1 m labels – 1 m (l: E_a)</p>		

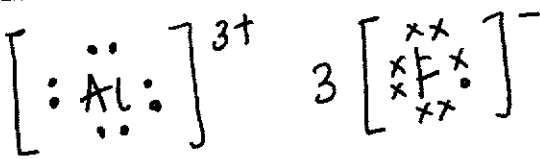
Qn	Answers	Mark	Guidance
7a	<p><u>Mobile</u> electrons in graphite acts as charge carriers + <u>mobile</u> ions in dilute aqueous sodium chloride act as charge carriers ;</p> <p>Graphite electrodes remain chemically unchanged + water (in dilute aqueous sodium chloride) decomposes (to form hydrogen and oxygen gas) ;</p>	2	<p>A: H⁺ and OH⁻ ions selectively discharged A: chemically changed</p>
7bi	<p>(gas collected in test-tube Y) oxygen / O₂ +</p> <p>(gas collected in test-tube Z) hydrogen / H₂ ;</p>	1	
7bii	<p>(anode / positive electrode) 4OH⁻(aq) → 2H₂O(l) + O₂(g) + 4e⁻ ;</p> <p>(cathode / negative electrode) 2H⁺(aq) + 2e⁻ → H₂(g) ;</p> <p>Number of moles of electrons lost at anode is the same as the number of moles of electrons gained at the cathode + 2 moles of H₂ is produced with 1 mole of O₂ ;</p> <p>same amount of gas occupies the same volume at the same temperature and pressure (and so, volume ratio is the same as mole ratio) ;</p>	4	<p>OWTTE A: balanced overall equation A: for every 4 moles of electrons transferred</p>
7ci	<p>(gas collected in test-tube W) chlorine / Cl₂ +</p> <p>(gas collected in test-tube X) hydrogen / H₂ ;</p>	1	
7cii	1:1	1	
7d	<p>(colour in beaker 1) violet / purple +</p> <p>(colour in beaker 2) green ;</p> <p>In beaker 1, H⁺ and Cl⁻ ions are selectively discharged (at the cathode and anode respectively) + leaving behind <u>alkaline NaOH</u> solution ;</p> <p>In beaker 2, H⁺ and OH⁻ ions are selectively discharged (at the cathode and anode respectively) + leaving behind a (more concentrated) solution of <u>neutral NaCl</u> ;</p>	3	<p>A: blue</p> <p>A: comparison of concentration of H⁺ and OH⁻ ions</p>
8ai	 <p> <ul style="list-style-type: none"> • Correct arrangement of electrons for Al³⁺ & '3+' charge • Correct arrangement of electrons for F⁻ & '-' charge • Charges balanced </p>	2	

Qn	Answers	Mark	Guidance
	All 3 correct – 2 m 1 – 2 correct – 1 m		
8aii	<p>(any 3)</p> <ul style="list-style-type: none"> • Compounds formed between metals and non-metals are usually ionic (so, they have high melting points and conduct electricity when molten) ; • Aluminium chloride has a simple molecular structure • Less energy is needed to overcome weak intermolecular forces of attraction (resulting in low melting points) • Exists as (electrically neutral) molecules when molten / no mobile charge carriers when molten (resulting in poor electrical conductivity) <p>OR</p> <ul style="list-style-type: none"> • Compounds formed between metals and non-metals are usually ionic (so, they have high melting points and conduct electricity when molten) ; • Aluminium chloride should have a giant ionic structure ; • More energy is needed to overcome strong electrostatic forces of attraction between (oppositely-charged) ions (resulting in high melting points but melting point of aluminium chloride is low) • Ionic compounds conduct electricity when molten due to mobile ions (but aluminium chloride is a poor electrical conductor when molten) <p><i>Minus 1 mark if student states that aluminium chloride <u>is</u> an ionic compound or <u>has</u> a giant ionic structure</i></p>	3	
8bi	Beryllium oxide is amphoteric + magnesium oxide is basic	1	A: reacts with acids & alkalis + reacts with acids
8bii	<p>(any 2)</p> <ul style="list-style-type: none"> • High melting/boiling point • Semi-conductor / non-conductor of electricity • Insoluble in water / organic solvents • Brittle / Hard 	1	R: High density
9ai	<p>Sulfur is oxidised as oxidation state of sulfur increases from +2 in $S_2O_3^{2-}$ to +2.5 in $S_4O_6^{2-}$;</p> <p>Iodine is reduced as oxidation state of iodine decreases from 0 in I_2 to -1 in I^- ;</p>	2	

Qn	Answers	Mark	Guidance
9aii	$\text{No. of moles of } \text{S}_2\text{O}_3^{2-} = 24.70 \times 10^{-3} \times 0.100$ $= 2.47 \times 10^{-3} \text{ mol/dm}^3 ;$ $\text{No. of moles of HClO} = \text{no. of moles of I}_2$ $= 2.47 \times 10^{-3} \div 2$ $= 1.24 \times 10^{-3} \text{ mol} ;$	2	Allow ECF
9b	(Yes) $\% \text{ Cl in NaClO} = \frac{35.5}{74.5} \times 100 = 47.7 \%$ $\% \text{ Cl in Ca(ClO)}_2 = \frac{71}{143} \times 100 = 49.7 \%$ Cl_2 contains 100% chlorine 2 correct calculations + statement – 2m Any one correct calculation – 1m	2	
9ci	(any one) <ul style="list-style-type: none"> • Different precisions/significant figures • Different volumes of water used 	1	
9cii	$\text{Mass of chlorine} = 2.86 \times 177 \times 10^{-3} = 0.50622 \text{ g} ;$ $\text{Solubility} = 0.50622 \div 71 \div 100 \times 10^{-3} = 0.0713 \text{ mol/dm}^3 ;$	2	Allow ECF
9ciii	(any one) <ul style="list-style-type: none"> • higher solubility of chlorine + less harmful chlorine (gas) released (OWTTE) • lower water evaporation + less harmful chlorine (gas) released (OWTTE) • reduces energy consumption/less energy needed + less crude oil / fossil fuels used • less CO_2 produced from burning fuels to heat the pool + which causes global warming 		
9di	$\text{NH}_3(\text{aq}) + 2\text{HOCl}(\text{aq}) \rightarrow \text{NHC}_2(\text{aq}) + 2\text{H}_2\text{O}(\text{l}) ;$	1	State symbols not required
9dii	(any one) <ul style="list-style-type: none"> • $\text{pH} > 5.5 / 6$ or pH between $5.5 / 6$ to 8 ; <input type="checkbox"/> • low concentration of $\text{Cl}_2/\text{HOCl}/\text{NH}_3$; 	1	A: ensure swimmers shower before entering the pool R: High pH

Paper 2 Section B

Qn	Answers	Mark	Guidance
10a	Both acids ionise <u>in water / aqueous solution</u> to <u>form H⁺ ions</u> / are <u>dibasic acids</u> ;	1	
10b	<p><u>Difference:</u> pH of malonic acid is higher than that of sulfuric acid / ORA</p> <p>malonic acid reacts slower with sodium carbonate</p> <p><i>Both differences – 1m</i></p> <p><u>explanation:</u> malonic acid is a weak acid which ionises partially in water + sulfuric acid is a strong acid which ionises completely in water ;</p> <p>malonic acid has a lower concentration of H⁺ ions compared to sulfuric acid (at any point in time) ;</p> <p><u>similarity:</u> both acids produce the same volume of CO₂ gas ;</p> <p><u>explanation:</u> same amount of H⁺ ions that react with sodium carbonate ;</p>	5	
10ci	Oxidation ;	1	
10cii	$ \begin{array}{ccccccc} & & \text{H} & & \text{H} & & \text{H} \\ & & & & & & \\ \text{H} & - & \text{O} & - & \text{C} & - & \text{C} & - & \text{C} & - & \text{O} & - & \text{H} \\ & & & & & & & & \\ & & & & \text{H} & & \text{H} & & \text{H} \end{array} $	1	
10ciii	alcohol	1	A: diol
10civ	No + different molecular formula + C ₃ H ₄ O ₄ (malonic acid) vs C ₃ H ₄ O ₂ (compound B) ;	1	A: compare no. of O atoms
11ai	Yes + same molecular formula of C ₆ H ₁₂ + different structural formula ;	1	A: structure A: same no. of C and H atoms
11aii	<p>Similarity: Both undergo complete combustion to give CO₂ and H₂O ;</p> <p>C₆H₁₂ + 9O₂ → 6CO₂ + 6H₂O ;</p>	5	

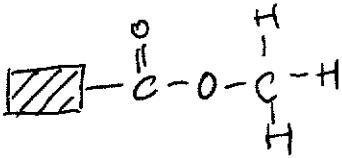
Qn	Answers	Mark	Guidance
	<p>Difference: Hexene undergoes <u>addition</u> reaction with aqueous bromine + cyclohexane does not react ;</p> <p>Observations: hexene decolourises orange/red-brown aqueous bromine + no observable change for cyclohexane ;</p> <p>$C_6H_{12} + Br_2 \rightarrow C_6H_{12}Br_2$;</p>		<p>A: aqueous Br_2 remains orange / red- brown</p> <p>R: compare sooty flame</p> <p>R: orange- brown</p>
11bi	Ester	1	
11bii		1	
11biii	<p>Plants used to make vegetable oil for biofuel can be regrown / replanted / replaced (renewable)</p> <p>OR</p> <p>Crude oil is finite / a limited resource ;</p> <p>CO_2 is absorbed during <u>photosynthesis</u> which offsets the CO_2 produced when biofuel is burnt (environmentally sustainable) ; OWTTE</p>	2	<p>R: equal / net is zero</p>