

Visit

FREETESTPAPER.com

for more papers



Website: [freetestpaper.com](http://www.freetestpaper.com)



[Facebook.com/freetestpaper](https://www.facebook.com/freetestpaper)



[Twitter.com/freetestpaper](https://www.twitter.com/freetestpaper)

Class:	Register No:	Name:
 CRESCENT GIRLS' SCHOOL SECONDARY FOUR PRELIMINARY EXAMINATION 2024		
CHEMISTRY		6092/01
Paper 1 Multiple Choice		28 August 024
Additional Materials: Multiple Choice Answer Sheet		1 hour
READ THESE INSTRUCTIONS FIRST		
Write in soft pencil. Do not use staples, paper clips, highlighters, glue or correction fluids. Write your name, index number and class on the Answer Sheet in the spaces provided. DO NOT WRITE ON ANY BARCODES.		
There are forty questions on this paper. Answer all questions. For each question, there are four possible answers, A, B, C and D . Choose the one you consider correct and record your choice in soft pencil on the OTAS sheet.		
Read the instructions on the Answer Sheet very carefully.		
Each correct answer will score one mark. A mark will not be deducted for a wrong answer. Any rough working should be done in this booklet A copy of the Periodic Table is printed on page 19 . The use of an approved scientific calculator is expected, where appropriate.		

This booklet consists of 19 printed pages, including the cover page.

- 1 A student measures the rate of the reaction between marble chips, CaCO_3 , and dilute hydrochloric acid.

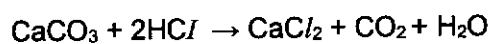

Which diagrams show the apparatus that are suitable for this experiment?

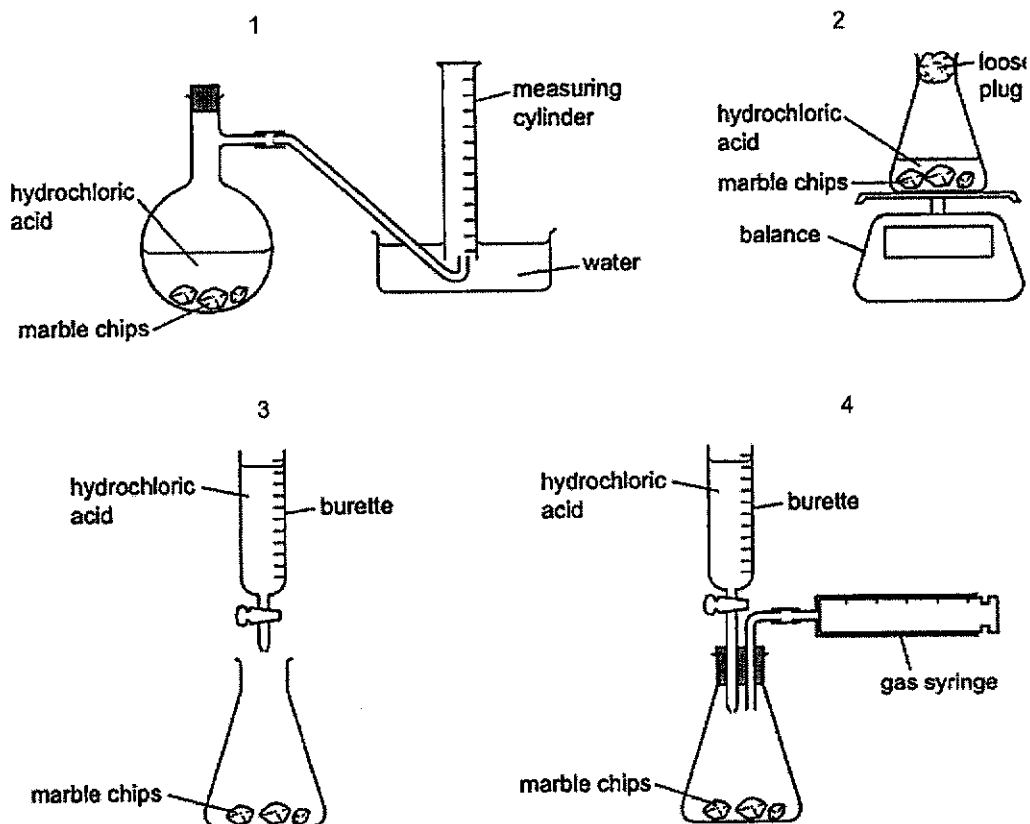

- A 1 and 2
 B 1, 2 and 4
 C 2 and 3
 D 2, 3 and 4

- 2 Chromatograms of a urine sample using two different solvents are shown below.

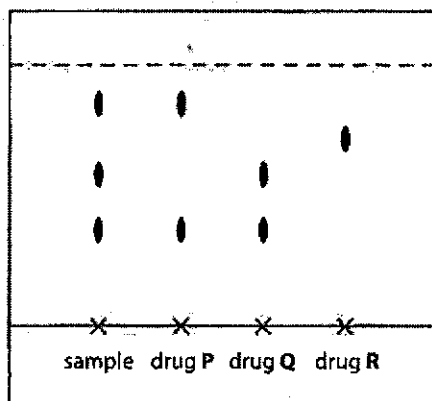

chloroform solvent used

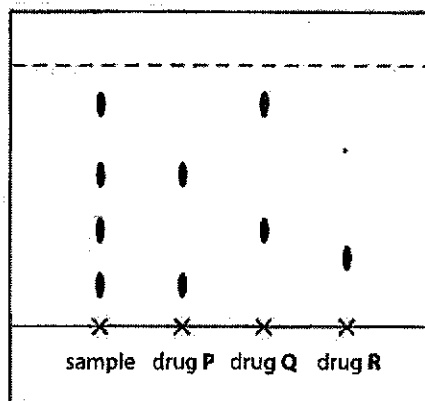

propanol solvent used

Based on the two chromatograms, which drug(s) is/are present in the urine sample?

- A drug P only
 - B drug Q only
 - C drugs P and Q only
 - D drugs P, Q and R
- 3 Since the discovery of graphite, scientists have been able to extract a single layer of carbon atoms (known as graphene) and convert it to another material known as graphane by attaching one hydrogen atom to each carbon atom as shown below.

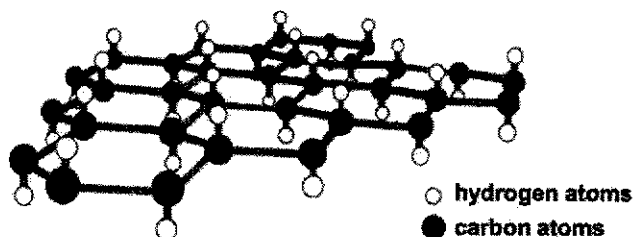

Which property of graphene is **not** likely to be shared by graphane?

- A It is insoluble in water.
- B It is very strong.
- C It has a high melting point.
- D It is an electrical conductor.

- 7 The diagram below shows the bonding between P and Q in the covalent molecule, PQ₂.

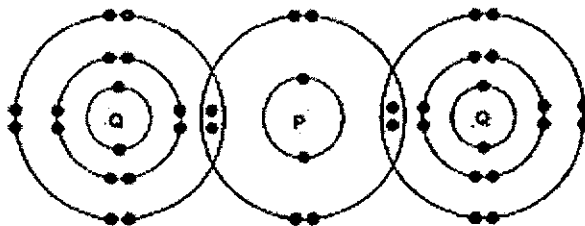

What are the electronic structures of atoms P and Q before combining together to form the above molecule?

	P	Q
A	2.8	2.8.8
B	2.6	2.8.7
C	2.6	2.8.6
D	2.4	2.8.7

- 8 0.1 mole of a chloride XCl₂ combines with 10.8 g of water to form the hydrated salt, XCl₂.nH₂O.

What is the value of n?

- A 6 B 8
C 10 D 12

- 9 Ammonia reacts with chlorine according to the equation shown below:

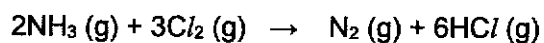

If 90 cm³ of ammonia is mixed with 60 cm³ of Cl₂ and all the volumes were measured at room temperature and pressure, what is the total volume of gases at the end of the reaction?

- A 20 cm³
B 120 cm³
C 140 cm³
D 190 cm³

- 10 When 4.8 g of magnesium is heated in a crucible, 5.9 g of magnesium oxide is formed.

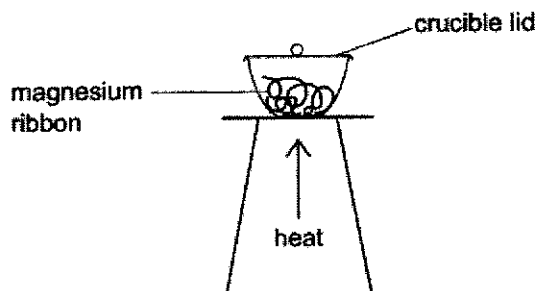

What is the percentage yield of magnesium oxide?

- A 53% B 74% C 80% D 81%
- 11 A student is given two samples, one of which is aluminium oxide and the other is magnesium carbonate. He needs to find a method to identify the two samples.

Which of the following show(s) the correct method(s) and observation(s)?

	method	observation(s)
1	add nitric acid	only aluminium oxide dissolves
2	add nitric acid	both samples dissolve. Effervescence is observed in the reaction with magnesium carbonate
3	add sodium hydroxide	only aluminium oxide dissolves
4	add sodium hydroxide	both samples dissolve. Effervescence is observed in both the reactions

- A 1 and 4 only
 B 2 only
 C 2 and 3 only
 D 3 only

- 12 Butterfly pea flower extract is commonly used in drinks nowadays and it changes colour according to different pH values. The table below shows the colours of butterfly pea flower extract at different pH values.

pH range	colour
0 – 3	violet
4 – 8	blue
9 – 11	green
12 – 14	yellow

Which pair of substances can be distinguished by adding butterfly pea flower extract to each substance separately?

- A acid rain and aqueous sodium chloride
 B aqueous ammonia and limewater
 C aqueous sodium sulfate and aqueous sodium chloride
 D dilute hydrochloric acid and dilute sulfuric acid
- 13 Which reaction will produce the least volume of carbon dioxide?
- A sodium carbonate and hydrochloric acid
 B copper(II) carbonate and hydrochloric acid
 C magnesium carbonate and sulfuric acid
 D lead(II) carbonate and sulfuric acid

- 14 The table below shows the results of some tests carried out on separate portions of a solution M.

test	observation
aqueous sodium hydroxide added	test-tube feels warm and no precipitate forms
acidified aqueous silver nitrate added	white precipitate forms

What could be the identity of solution M?

- A hydrochloric acid
 B potassium sulfate
 C sodium chloride
 D zinc sulfate

- 15 A student stated that since low temperatures produce a greater yield of ammonia, the reaction should be carried out at 50 °C instead of 450 °C.

Which statement best explains why the reaction is **not** carried out at 50 °C?

- A Ammonia is unstable at 50 °C.
 B The reactants are unstable at 50 °C.
 C The reaction is too slow at 50 °C.
 D The reaction mixture is easily separated at higher temperatures.
- 16 Ammonium chloride is heated strongly in a boiling tube. Damp blue and red litmus papers were placed at the mouth of the boiling tube for the gases produced.

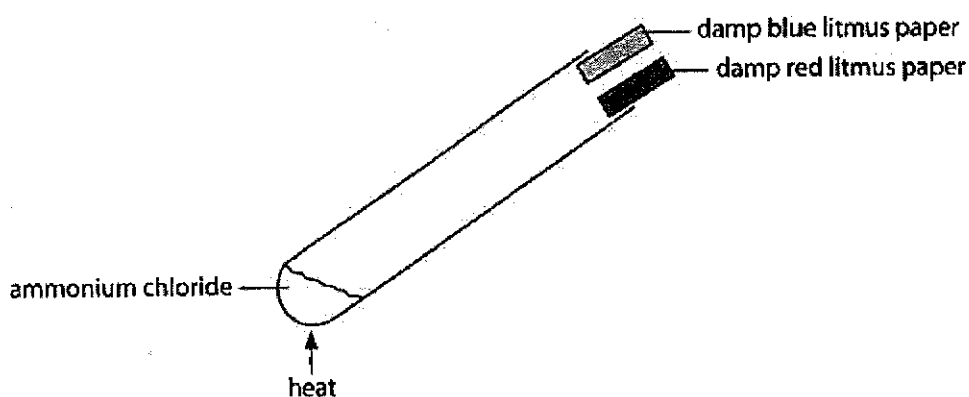

Which row shows the correct sequence of observations that would be made?

	first observed colour change	final colour of both litmus papers
A	The damp blue litmus paper turns red.	red
B	The damp blue litmus paper turns red then bleaches.	white
C	The damp red litmus paper turns blue.	blue
D	The damp red litmus paper turns blue.	red

- 17 Which are redox reactions?

- 1 $\text{HCl} + \text{NaOH} \rightarrow \text{NaCl} + \text{H}_2\text{O}$
- 2 $\text{Zn} + 2\text{HNO}_3 \rightarrow \text{Zn}(\text{NO}_3)_2 + \text{H}_2$
- 3 $\text{Ag}_2\text{SO}_4 + 2\text{NaCl} \rightarrow 2\text{AgCl} + \text{Na}_2\text{SO}_4$
- 4 $2\text{Fe}^{2+} + \text{Cl}_2 \rightarrow 2\text{Fe}^{3+} + 2\text{Cl}^-$

- A 1, 2 and 3 B 1 and 3
 C 2 and 4 D 3 and 4

- 18 Dry hydrogen gas is passed over a heated brown powdered solid and then through a cooled U-tube before the excess of hydrogen is burned in air.

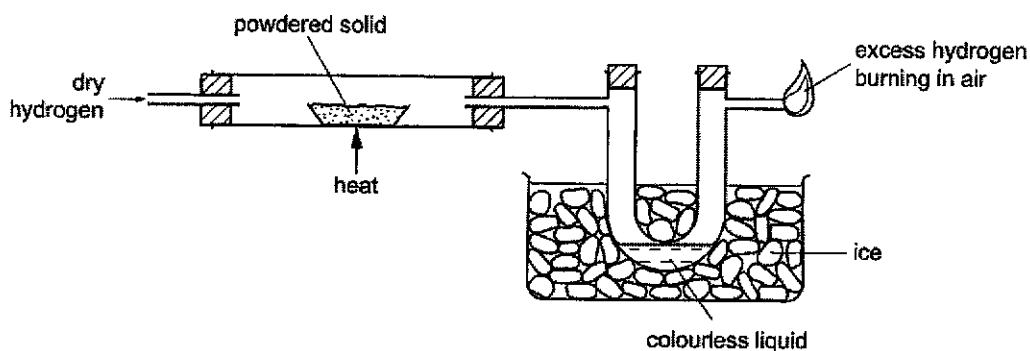

A colourless liquid collects in the U-tube. What could the brown powdered solid be?

- A aluminium oxide
 B copper(II) oxide
 C iron(III) oxide
 D magnesium oxide
- 19 Equal masses of different metals 1 to 4 are placed in the test tubes containing an equal volume of hydrochloric acid of equal concentration. The thermometers show the maximum temperature recorded for the reaction. (The room temperature is 25 °C.)

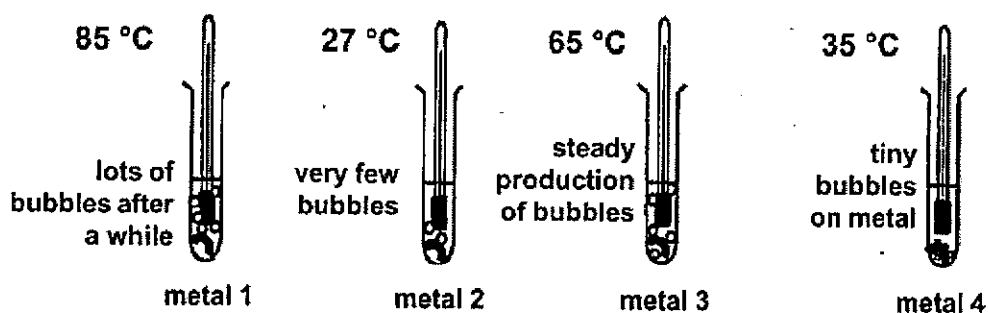

Which statements are most likely to be true?

- I Metal 3 will displace metals 2 and 4 from their aqueous salt solutions.
 II Metal 2 can likely be extracted by chemical reduction of its oxide by carbon.
 III Metal 1 is likely to be obtained by electrolysis of its molten chloride.

- A I, and II only
 B I and III only
 C II and III only
 D I, II and III

- 20 The energy profile diagram represents a chemical reaction carried out with a catalyst and without a catalyst.

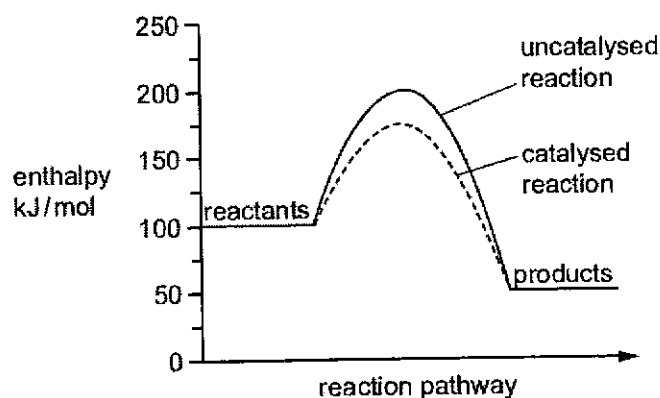

What is the enthalpy change for the catalysed reaction?

- A - 125 kJ/mol
 B - 50 kJ/mol
 C + 75 kJ/mol
 D + 100 kJ/mol
- 21 Hydrogen peroxide reacts with potassium iodide in the presence of dilute acid to produce iodine molecules as shown in the equation below.

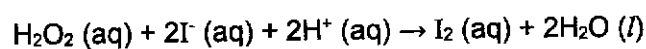

Which factor would **not** affect the rate of this reaction?

- A Concentration of hydrogen peroxide
 B Concentration of potassium iodide
 C Pressure of the reacting vessel
 D Temperature of the reacting vessel and its surroundings

- 22 In the graph shown, curve 1 was obtained by the decomposition of 100 cm³ of 1.0 mol/dm³ hydrogen peroxide solution with manganese(IV) oxide as the catalyst. The equation for this reaction is shown.

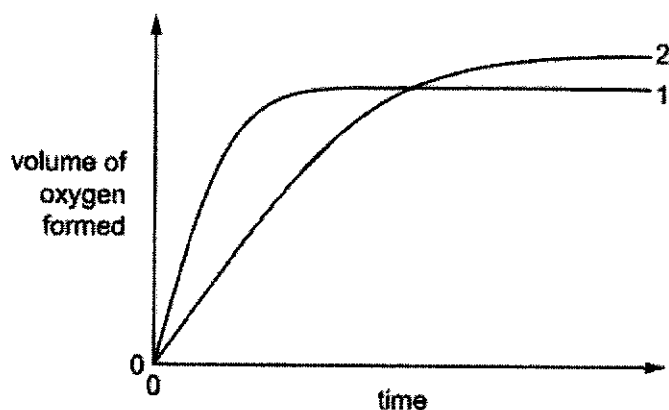
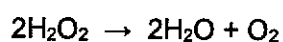

Which change to the original experimental conditions would produce curve 2?

- A adding some 0.1 mol/dm³ hydrogen peroxide solution
 B lowering the temperature
 C using a different catalyst
 D using less manganese(IV) oxide
- 23 In which set-up will the bulb light up?

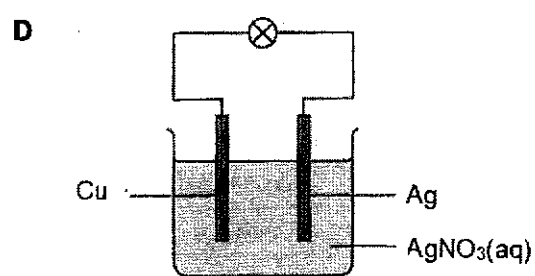
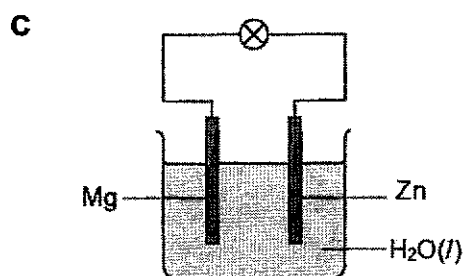
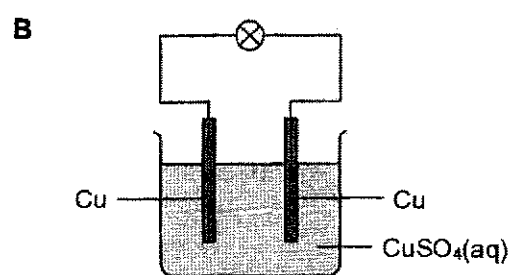
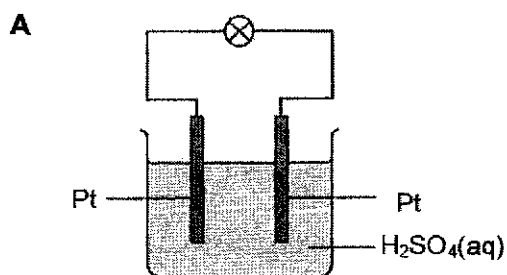

- 24 During an electrolysis, X^+ and Y^- ions are selectively discharged as shown in the equations below:



What can the electrolyte be?

- A aqueous magnesium chloride
 B aqueous sodium sulfate
 C concentrated magnesium chloride
 D molten potassium chloride
- 25 In which electrolysis experiment would there be no change in the concentration of the solution?

	<u>electrodes</u>	<u>electrolyte</u>
A	carbon	aqueous copper(II) sulfate
B	copper	aqueous copper(II) sulfate
C	carbon	concentrated potassium chloride
D	platinum	dilute sulfuric acid

- 26 Methane reacts very slowly with air at room temperature. However, if a transition metal T is added to the methane-air mixture, the methane ignites quickly.

A student made some statements about the observation.

- I Addition of T reduces the activation energy.
 II Addition of T increases the enthalpy change.
 III Addition of T increases the rate of reaction.
 IV Addition of T reduces the energy of the reactants.

Which statements are correct?

- A I and II only
 B I and III only
 C II and III only
 D All of the above

- 30 Figure below shows the fractional distillation of petroleum.

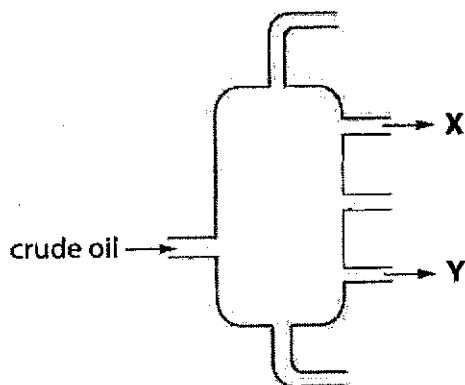

Which statement best describes the fractions at X and Y?

- A The molecules in fraction X contain more carbon atoms than the molecules in fraction Y.
 B The molecules in fraction X are more flammable than the molecules in fraction Y.
 C The molecules in fraction X are larger than the molecules in fraction Y.
 D The molecules in fraction X have higher boiling points than the molecules in fraction Y.
- 31 An unsaturated hydrocarbon, C_4H_6 reacts with 0.10 mole of hydrogen gas to form the corresponding alkane.

What is the mass of C_4H_6 that is required to react with the hydrogen gas completely?

- A 0.90 g
 B 1.80 g
 C 2.70 g
 D 3.60 g
- 32 Which one of the following shows the correct structural formula and name of the ester formed when methanoic acid reacts with propanol?

	<u>structural formula</u>	<u>name</u>
A	$CH_3CH_2COOCH_3$	methyl propanoate
B	$CH_3CH_2COOCH_3$	propyl methanoate
C	$HCOOCH_2CH_2CH_3$	methyl propanoate
D	$HCOOCH_2CH_2CH_3$	propyl methanoate

33 Which structures are isomers?

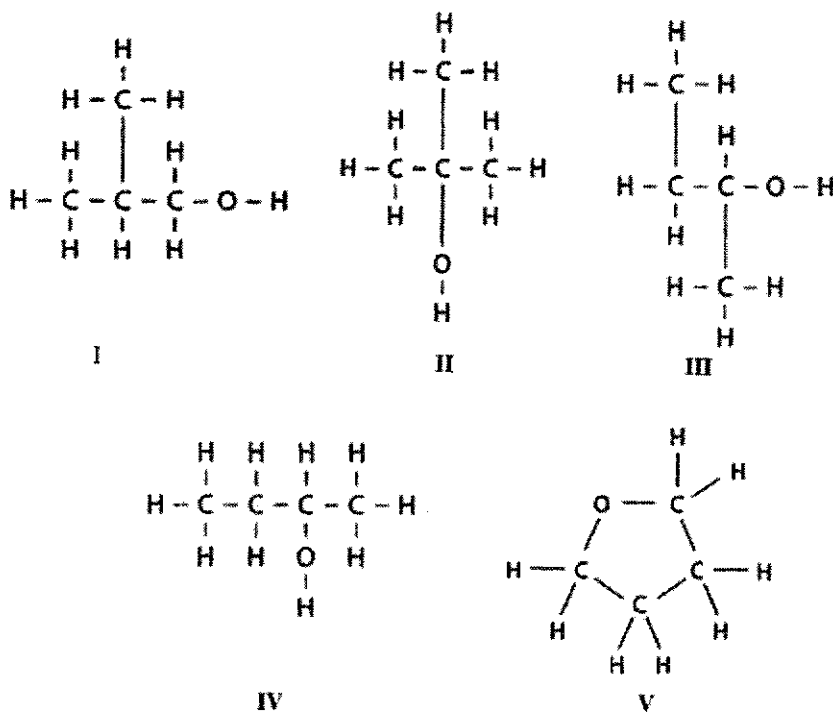

- A** I, II and IV **B** I, II and V
C I, III and IV **D** II, III and V

34 The diagram below shows an organic compound, cysteine.

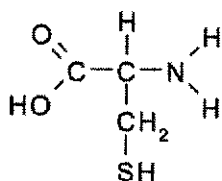

Which statement about cysteine is true?

- A** Effervescence is observed when magnesium metal is added to cysteine.
B It decolourises acidified potassium manganate(VII).
C It forms a polymer with the same linkage as terylene.
D It forms an addition polymer with other units of cysteine.

- 35** An organic compound M undergoes a 2-stage process to form a compound N of chemical formula: $\text{CH}_3\text{CH}_2\text{CH}_2\text{COOH}$.

The reagents and conditions of the 2 reactions are as follows:

stage number	reagent(s)	conditions
1	steam	300 °C, 65 atm, Phosphoric(V) acid
2	acidified potassium manganate(VII)	heat

Which can be a possible identity of compound M?

- A** butane
 - B** butene
 - C** propane
 - D** propene
- 36** Which statement is true about addition polymers and condensation polymers?
- A** Addition polymers are formed from alkenes while condensation polymers are formed from alkanes.
 - B** Addition polymers produce water as a by-product whereas condensation polymers do not produce any by-products.
 - C** Condensation polymers could produce water as a by-product whereas addition polymers do not produce any by-product.
 - D** Nylon is an example of an addition polymer where terylene is an example of a condensation polymer.

- 37 Kevlar is a polymer with high tensile strength, which is five times greater than steel. It is a lightweight and strong fibre with many applications ranging from being used in bulletproof vests to tires. It has the structure below.

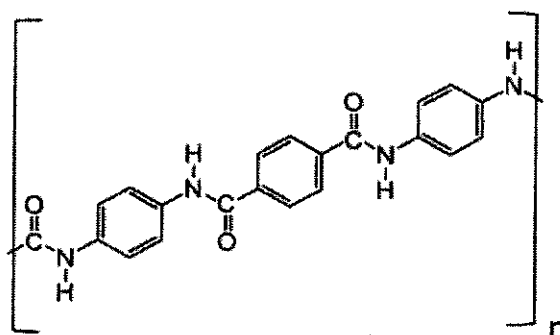

Which could be the monomer(s) for Kevlar?

- A
- B
- C and
- D and

- 38 To reduce atmospheric pollution, the waste gases from a coal-burning power station are passed through powdered calcium carbonate.

Which waste gas will **not** be removed by the calcium carbonate?

- A carbon dioxide
 B nitrogen monoxide
 C phosphorus(V) oxide
 D sulfur dioxide

39 Which statements are always true of methane and carbon dioxide?

- 1 Both gases can be produced by cattle.
- 2 Both gases cause acid rain.
- 3 Methane burns in limited oxygen to produce carbon dioxide.
- 4 They are both greenhouse gases.

- A 1 and 2 only
B 1 and 4 only
C 2 and 3 only
D 3 and 4 only

40 The figure below shows the reaction of zinc in air. When all the grey solid has turned yellow, the source of heat was removed. Upon cooling, the yellow solid turned white.

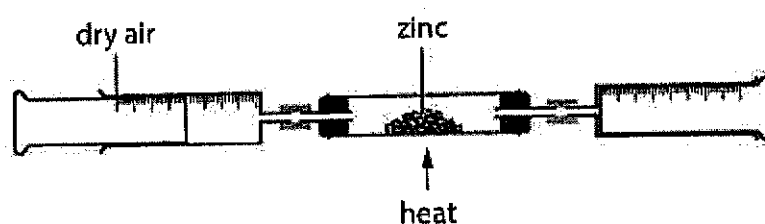

During the reaction, a sample of 250 cm^3 of air was used.

What is volume of the remaining air left after the experiment?

- A 52.5 cm^3 B 105 cm^3
C 197.5 cm^3 D 395 cm^3

The Periodic Table of Elements

		Group																
1	2	3	4	5	6	7	8	9	10	11	12	13	14	15	16	17	18	
3 Li lithium 7	4 Be beryllium 9	<div style="border: 1px solid black; padding: 5px; width: fit-content; margin: 0 auto;"> Key proton (atomic) number atomic symbol name relative atomic mass </div>															2 He helium 4	
11 Na sodium 23	12 Mg magnesium 24	1 H hydrogen 1	21 Sc scandium 45	22 Ti titanium 48	23 V vanadium 51	24 Cr chromium 52	25 Mn manganese 55	26 Fe iron 56	27 Co cobalt 59	28 Ni nickel 59	29 Cu copper 64	30 Zn zinc 65	5 B boron 11	6 C carbon 12	7 N nitrogen 14	8 O oxygen 16	9 F fluorine 19	10 Ne neon 20
19 K potassium 39	20 Ca calcium 40	3 La lanthanum 139	39 Y yttrium 89	40 Zr zirconium 91	41 Nb niobium 93	42 Mo molybdenum 96	43 Tc technetium —	44 Ru ruthenium 101	45 Rh rhodium 103	46 Pd palladium 106	47 Ag silver 108	48 Cd cadmium 112	13 Al aluminum 27	14 Si silicon 28	15 P phosphorus 31	16 S sulfur 32	17 Cl chlorine 35.5	18 Ar argon 40
37 Rb rubidium 85	38 Sr strontium 88	57-71 lanthanoids	72 Hf hafnium 178	73 Ta tantalum 181	74 W tungsten 184	75 Re rhenium 186	76 Os osmium 190	77 Ir iridium 192	78 Pt platinum 195	79 Au gold 197	80 Hg mercury 201	49 In indium 115	50 Sn tin 119	51 Sb antimony 122	52 Te tellurium 128	53 I iodine 127	54 Xe xenon 131	
55 Cs cesium 133	56 Ba barium 137	89-103 actinoids	80 Zn zinc 65	81 Tl thallium 204	82 Pb lead 207	83 Bi bismuth 209	84 Po polonium —	85 At astatine —	86 Rn radon —	87 Fr francium —	88 Ra radium —	89 Ac actinium —	69 Tm thulium 169	70 Yb ytterbium 173	71 Lu lutetium 175	118 Og oganesson —		
87 Fr francium —	88 Ra radium —	57 La lanthanum 139	58 Ce cerium 140	59 Pr praseodymium 141	60 Nd neodymium 144	61 Pm promethium —	62 Sm samarium 150	63 Eu europium 152	64 Gd gadolinium 157	65 Tb terbium 159	66 Dy dysprosium 163	67 Ho holmium 165	68 Er erbium 167	69 Tm thulium 169	70 Yb ytterbium 173	71 Lu lutetium 175	118 Og oganesson —	
		89 Ac actinium —	90 Th thorium 232	91 Pa protactinium 231	92 U uranium 238	93 Np neptunium —	94 Pu plutonium —	95 Am americium —	96 Cm curium —	97 Bk berkelium —	98 Cf californium —	99 Es einsteinium —	100 Fm fermium —	101 Md mendelevium —	102 No nobelium —	103 Lr lawrencium —	118 Og oganesson —	

The volume of one mole of any gas is 24 dm³ at room temperature and pressure (r.t.p.).
 The Avogadro constant, L = 6.02 × 10²³ mol⁻¹.

Class:	Register No:	Name:																	
 <p style="margin: 0;">CRESCENT GIRLS' SCHOOL SECONDARY FOUR PRELIMINARY EXAMINATION 2024</p>																			
CHEMISTRY Paper 2	6092/02 23 August 2024 1 hr 45 mins																		
READ THESE INSTRUCTIONS FIRST																			
<p>Candidates answer on the Question Paper. No Additional Materials are required. Write your name, register number and class in the spaces provided at the top of this page. Write in dark blue or black pen. You may use an HB pencil for any diagrams or graph. Do not use staples, paper clips, and glue or correction fluid.</p>																			
<p>Section A (70 Marks) Answer all questions Write your answers in the spaces provided.</p>																			
<p>Section B (10 Marks) Answer one question. Write your answers in the spaces provided.</p>																			
<p>The number of marks is given in brackets [] at the end of each question or part question. A copy of the Periodic Table is printed on page 23.</p>																			
<p>The use of an approved scientific calculator is expected, where appropriate.</p>																			
<table border="1" style="margin-left: auto; border-collapse: collapse;"> <thead> <tr> <th colspan="3" style="padding: 5px;">For Examiner's Use</th> </tr> </thead> <tbody> <tr> <td style="padding: 5px;">Section A</td> <td colspan="2" style="width: 100px;"></td> </tr> <tr> <td style="padding: 5px;">Section B</td> <td colspan="2"></td> </tr> <tr> <td rowspan="2" style="padding: 5px;">Deductions</td> <td style="padding: 5px;">Significant Figures</td> <td style="width: 50px;"></td> </tr> <tr> <td style="padding: 5px;">Units</td> <td></td> </tr> <tr> <td style="padding: 5px;">Total</td> <td colspan="2" style="text-align: center; font-size: 2em; font-weight: bold;">80</td> </tr> </tbody> </table>			For Examiner's Use			Section A			Section B			Deductions	Significant Figures		Units		Total	80	
For Examiner's Use																			
Section A																			
Section B																			
Deductions	Significant Figures																		
	Units																		
Total	80																		

This paper consists of **23** printed pages including cover page.

Section A

Answer **all** questions in this section in the spaces provided.

The total mark for this section is 70.

- A1** The figure below shows 'dot-and-cross' diagrams for molecules that contain elements from the first two periods of the Periodic Table. The elements are represented by the letters **M**, **Q**, **R**, **T** and **Z**.

Each diagram shows outer electrons only.

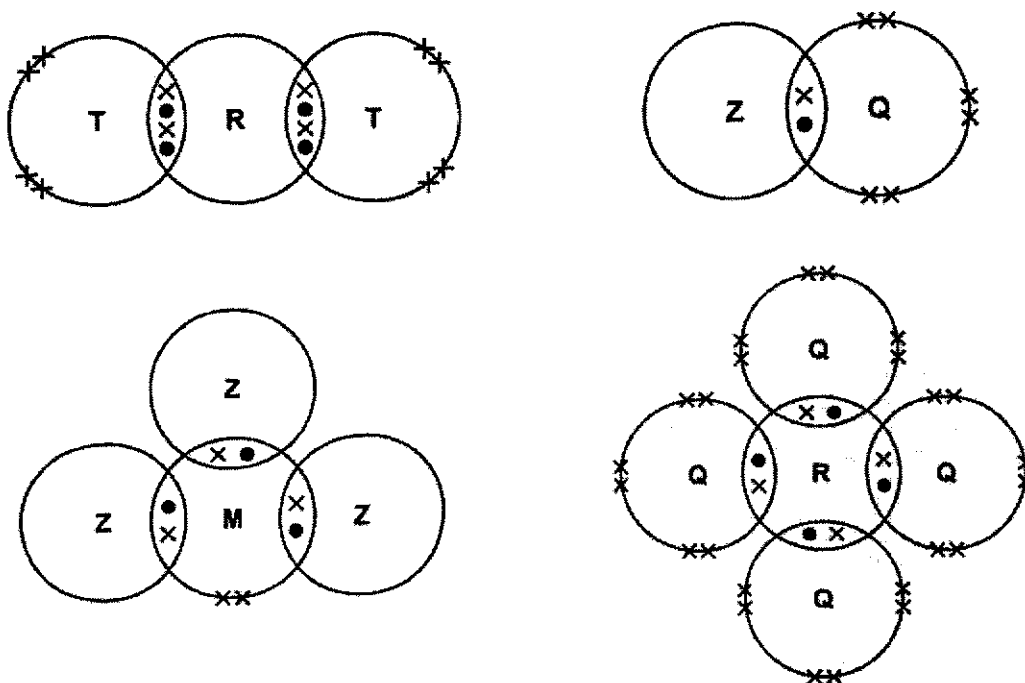

Use the letters **M**, **Q**, **R**, **T** and **Z** to answer the questions below.

- (a) Which element can form an ion with a charge of 1-? [1]

- (b) Which element can lose, gain and share electrons? [1]

- (c) Which element can form an acidic oxide? [1]

- (d) Which element forms a triple covalent bond? [1]

- (e) (i) Potassium reacts with element T to form a compound. [2]

Draw a dot-and-cross diagram of the compound formed between potassium and element T. Show only the valence electrons.

- (ii) State one physical property of the above compound and explain the reason for the physical property. [2]

[Total: 8 marks]

A2 The table below shows information about the preparation of pure samples of some solid salts. **[5]**

Complete the table by filling in the missing information. Include state symbols with the formulae.

formulae of salt	formulae of reagent 1	formulae of reagent 2	method of preparation
CaCO_3 (s)			_____
Ag_2SO_4 (s)		H_2SO_4 (aq)	Adding excess solid to acid evaporation and crystallisation
NH_4NO_3 (s)	HNO_3 (aq)		_____
			evaporation and crystallisation

[Total: 5 marks]

A3 Nitrogen dioxide is an acidic oxide. It dissolves in water to form two acids, nitric acid and nitrous acid, HNO_2 in a single reaction.

(a) (i) Write a balanced chemical equation for the above reaction. **[1]**

(ii) Disproportionation is a reaction when the same substance is oxidised and reduced in the same reaction. **[2]**

Explain why the reaction in **(a)(i)** is a disproportionation reaction.

(b) One of the main sources of nitrogen monoxide, NO is from the combustion engines of vehicles.

(i) State how nitrogen monoxide, NO is formed in combustion engines of vehicles. [2]

(ii) Hence, explain with the aid of a chemical equation how nitrogen monoxide is removed by catalytic converters fitted in cars. [2]

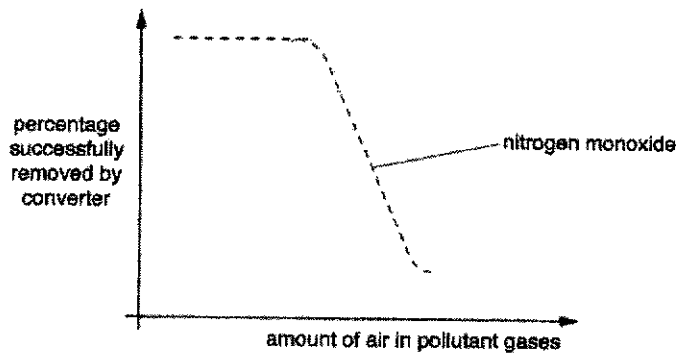

The amount of air in the pollutant gases that enter the catalytic converter affects the reactions in the converter.
 The graph shows the percentage of nitrogen monoxide that the catalytic converter successfully removed.

(iii) Using the equation in (ii) and the graph above, explain why the percentage of nitrogen monoxide successfully removed by catalytic converter decreases as the amount of air increases. [2]

[Total: 9 marks]

- A4** A student electrolysed aqueous copper(II) sulfate using two sets-ups shown below. The electrodes used in each set-up are made of the same material. However, the electrodes used in set-ups A and B are made of different materials.

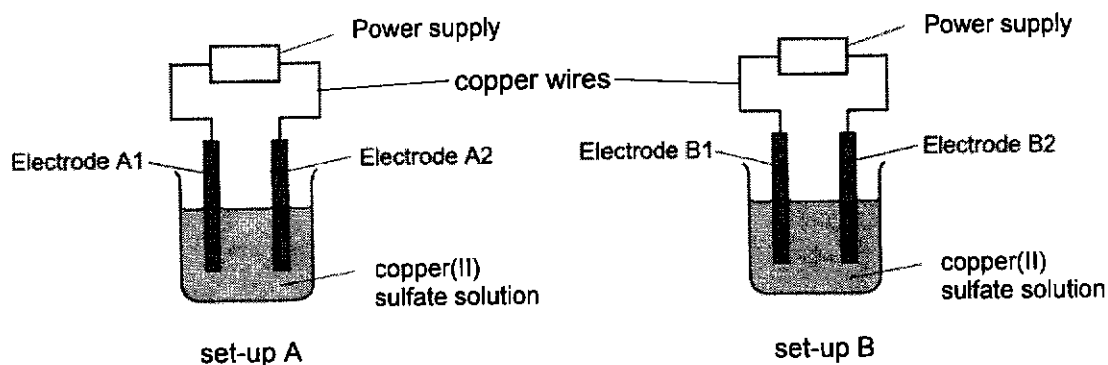

He recorded the following observations in the two set-ups.

set-up A	set-up B
mass of electrode A1 increased	mass of electrode B1 increased
mass of electrode A2 remained the same	mass of electrode B2 decreased
effervescence observed at electrode A2 blue copper(II) sulfate solution fades in colour.	no effervescence observed at B2. blue copper(II) sulfate solution remains unchanged.

- (a) Name the particles which transfer charges through the: [1]
- (i) copper wires _____
- (ii) copper(II) sulfate solution _____
- (b) State which electrode is the cathode in each set-up.
- Set-up A: _____ Set-up B: _____ [1]
- (c) Explain, with an appropriate equation, the increase in mass at electrodes at A1 and B1. [2]
- _____
- _____

- (d) Write the half-equations of the reactions taking place at Electrode A2 and Electrode B2. [2]

Half-equation at A2: _____

Half-equation at B2: _____

- (e) Describe how the electrolyte of set-up A would change by the end of experiment in terms of its pH and explain why. [2]

- (f) Suggest the materials that are used to make the electrodes in: [1]

(i) Set-up A: _____

(ii) Set-up B: _____

[Total: 9 marks]

- A5** The table below shows four different experiments that were conducted with various concentrations and volumes of three different acids that reacted with excess zinc.

experiment	acid	concentration of acid in mol/dm ³	Volume of acid in cm ³
1	hydrochloric acid	0.10	100
2	hydrochloric acid	0.20	100
3	ethanoic acid	0.10	100
4	sulfuric acid	M	N

- (a) The chemical equation between zinc and hydrochloric acid is shown below.

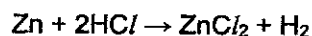

- (i) Find the number of moles of hydrochloric acid that reacted in Experiment 1. [1]

- (ii) Hence, find the volume of gas that is evolved in Experiment 1. [2]

- (iii) The graph below shows the graph for Experiment 1. Hence, sketch the graph for Experiment 2 and label it as **Expt 2**. [1]

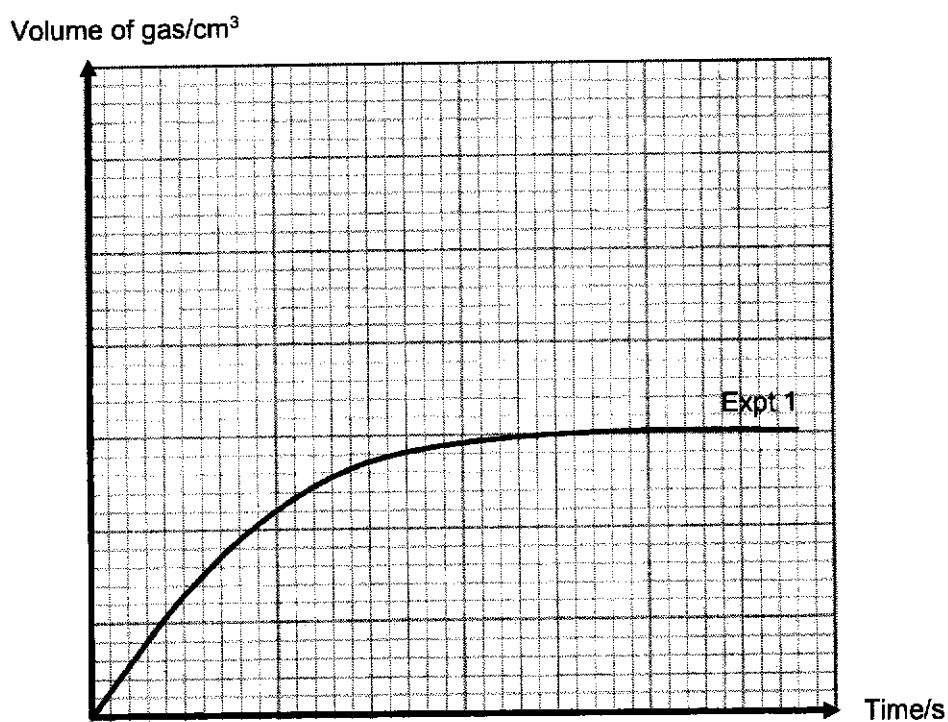

- (b) (i) Write an equation to show the chemical reaction between ethanoic acid and zinc. [1]
-
- (ii) Hence, sketch the graph for Experiment 3 in the same axes in (a)(iii) and label it as **Expt 3**. [2]

(iii) Explain the shape of your graph.

[3]

(c) Suggest values for M and N in the table above so that Experiment 4 can have the same graph as Experiment 2. [2]

M: _____

N: _____

[Total: 12 marks]

A6 Zinc is a transition metal found in Period 4 of the Periodic Table. Some properties of zinc are shown in the table below.

	zinc
electronic configuration	2.8.18.2
melting point/ $^{\circ}\text{C}$	419
density/ g/dm^3	2.99
formula of metal oxide	ZnO
colour of metal chloride	white

It is noted that zinc only forms one oxide and one chloride.

(a) Using the information from the table, suggest two reasons why zinc is not considered a typical transition metal. [2]

(b) A student is given an unknown colourless solution T.

(i) Describe a chemical test that would confirm that solution T contains zinc ions. [2]

Include any observations that you might see.

(ii) To identify the anion present, the student carried out the following test:

step number	procedure
1	Add aqueous barium chloride to a test tube containing solution T.
2	Measure the height of precipitate formed after 5 minutes.
3	Add excess dilute nitric acid to the above mixture.
4	Measure the height of the precipitate formed after 5 minutes.

The results obtained are shown in a graph below.

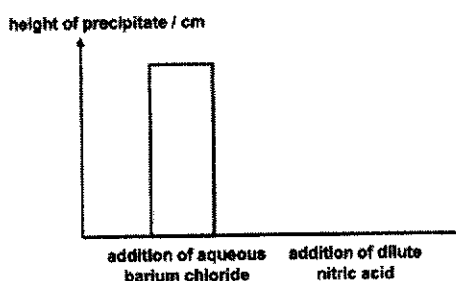

Based on the graph above, the student concluded that the anion is sulfate ion, but not carbonate ion. [3]

Do you agree with the student?

Explain your answer with reference to the graph.

[Total: 7 marks]

A7 The structures of three organic compounds are given in the table below.

organic compound	structure of compound
W	$ \begin{array}{cccc} & \text{H} & \text{H} & \text{H} & \text{H} \\ & & & & \\ \text{H} & - \text{C} & - \text{C} = & \text{C} & - \text{C} - \text{H} \\ & & & & \\ & \text{H} & & & \text{H} \end{array} $
X	$ \begin{array}{ccccccc} & & \text{O} & & \text{H} & & \text{H} & & \text{O} \\ & & & & & & & & \\ \text{H} & - \text{O} & - \text{C} & - & \text{C} & - & \text{C} & - & \text{C} & - \text{O} - \text{H} \\ & & & & & & & & & \\ & & & & \text{H} & & \text{H} & & & \end{array} $
Y	$ \begin{array}{ccccccc} & & \text{O} & & \text{H} & & \text{H} & & \text{H} \\ & & & & & & & & \\ \text{H} & - \text{O} & - \text{C} & - & \text{C} & - & \text{C} & - & \text{C} & - \text{O} - \text{H} \\ & & & & & & & & \\ & & & & \text{H} & & \text{H} & & \text{H} \end{array} $

- (a) (i) State the compound that can undergo addition polymerisation and condensation polymerisation on its own respectively. [2]

Addition polymerisation: _____

Condensation polymerisation: _____

- (ii) Draw two repeat units of the respective addition and condensation polymer. [2]

Addition Polymer:

Condensation Polymer:

- (b) (i) Draw the structural formula of a simple molecule that can combine with X to undergo condensation polymerisation. [1]
- (ii) Hence, draw the structure of the polymer formed. [1]
- (iii) Name the small molecule that is formed as a by-product. [1]
-

- (c) (i) Describe a test that can be used to differentiate between organic compounds X and Y. [2]

- (ii) Name a reagent that can be used to differentiate organic compound W from compounds X and Y. [1]

[Total: 10 marks]

- A8** A pH probe attached to a computer measures pH changes during some titration experiments. In experiment 1, 0.1 mol/dm^3 of hydrochloric acid was added from a burette to 25.0 cm^3 of dilute sodium hydroxide. The pH probe measured the pH during the experiment. Graph 1 shows the results.

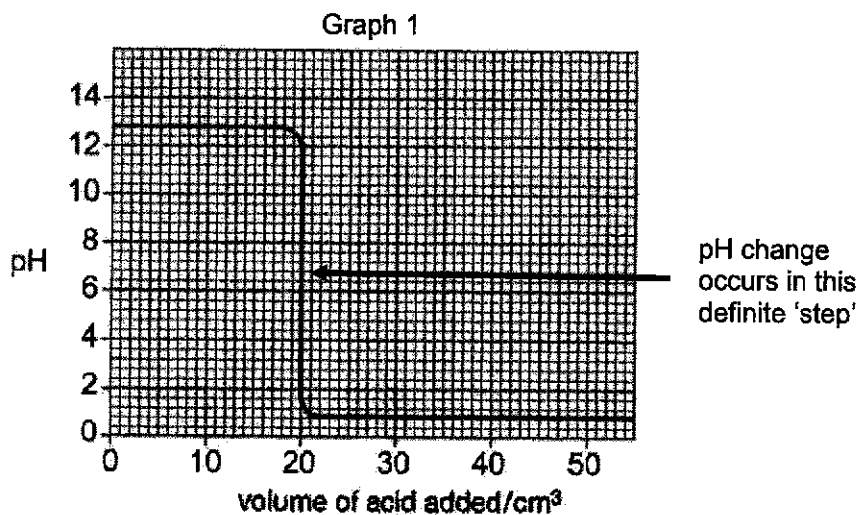

In experiment 2, 0.1 mol/dm^3 hydrochloric acid was added from a burette to 25.0 cm^3 of dilute sodium carbonate.

Graph 2 shows the results.

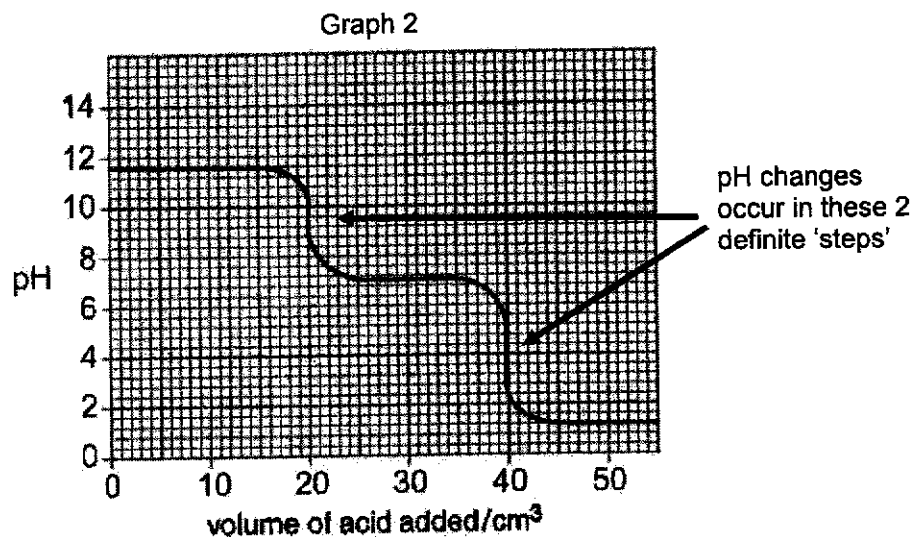

The reaction between sodium carbonate and hydrochloric acid happens in two stages.

Stage 1: Sodium carbonate reacts with dilute hydrochloric acid to form sodium hydrogencarbonate and a neutral salt.

Stage 2: Sodium hydrogencarbonate undergoes a further reaction with hydrochloric acid. An indicator can be used to see when a pH change happens in the definite 'step'.

The diagram shows the colours of some indicators at different pH values. In between the colours, most indicators change colour over a range of pH values.

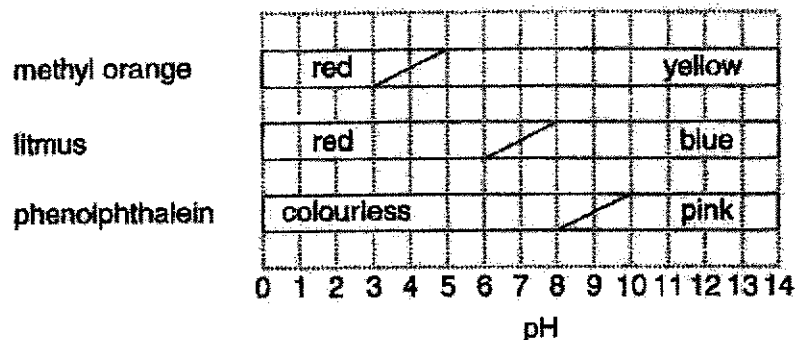

key



gradual colour change

The best indicator for a titration gives a distinct colour change when a 'definite step' occurs.

In Experiment 1, it is found that all three indicators are suitable to give an accurate titration volume.

- (a) Use the information to calculate the concentration of sodium hydroxide used in Experiment 1. [2]

- (b) A third experiment was carried out. A solution of the sodium hydroxide of the same concentration as that used in Experiment 1 was used. [1]

In this experiment, hydrochloric acid of a concentration of 0.20 mol/dm^3 was used.

Using the axes for Graph 1 above, sketch the graph you would expect from this experiment and label it **Experiment 3**.

- (c) Identify two differences between the pH graphs for Experiment 1 and 2. [2]

- (d) (i) Identify the neutral salt formed in Stage 1 of Experiment 2 [1]

- (ii) Based on Graph 2, suggest the pH of sodium hydrogencarbonate. [1]

- (iii) Using the information from Graph 2, state and explain the indicator that is suitable to find the titration volume for Stage 1 in Experiment 2. [2]

(iv) Write a chemical equation for the reaction in Stage 2 of Experiment 2.

[1]

[Total: 10 marks]

Section B (10 Marks)

Answer only ONE question in this section.

EITHER**B9** Alkynes are a homologous series of hydrocarbons.

The structural formulae of two members of this series are shown below.

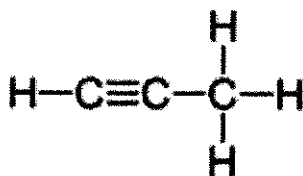

propyne

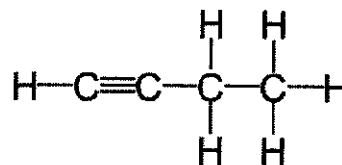

butyne

- (a) What is the functional group of this homologous series?
- [1]

Deduce the molecular formula of the first member of this homologous series.

- (b) The boiling points of four consecutive members of the alkyne series are shown in the table.

name of alkyne	boiling point/ $^{\circ}\text{C}$
propyne	-23.2
butyne	8.1
pentyne	
hexyne	71.2
heptyne	100

- (i) Predict the boiling point of pentyne and suggest a method to separate a mixture of pentyne and hexyne.
- [2]

- (ii) State and explain the trend of the boiling points down the table.
- [2]

- (c) Alkynes can be prepared by reacting a dibromoalkane with potassium hydroxide solution. An equation for the reaction is shown.

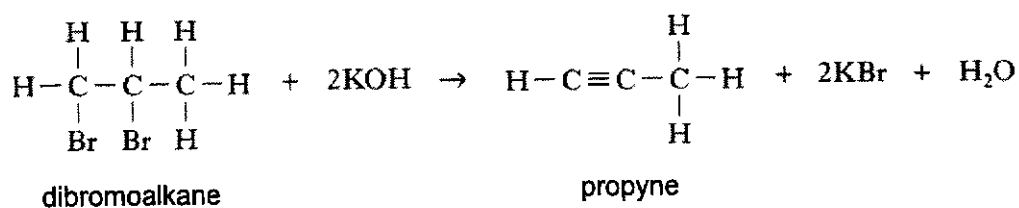

Another dibromoalkane shown below also reacts with potassium hydroxide solution.

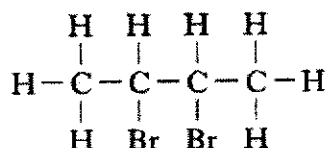

- (i) Draw the full structural formula of the alkyne formed. [1]

- (ii) Predict whether the dibromoalkane shown below forms an alkyne when it is added to potassium hydroxide solution. Explain your answer. [2]

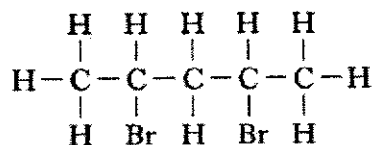

(d) Pentynes are also a member of the alkyne homologous series with 5 carbon atoms.

[2]

Draw the full structural formulae of two isomers of pentynes.

[Total: 10 marks]

OR
B9

Fluorine, chlorine, bromine and iodine are elements found in Group 17 of the Periodic Table. Some trends that can be observed as we go down Group 17 are atomic radius and ionic radius.

Table 1 below shows the atomic and ionic radii of halogens.

halogen	atomic radius/ nm	ionic (X ⁻) radius/ nm
F	0.071	0.133
Cl	0.099	0.181
Br	0.114	0.196
I	M	0.220

Table 1

Electron affinity, shown in Table 2 below, is a measure of the attraction between the incoming electron and the nucleus. The first electron affinity is the energy change when 1 mole of gaseous atoms gain an electron to form 1 mole of gaseous ions. The reaction can be shown in an equation below:

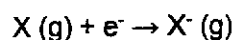

Table 2 shows the first electron affinities of Group 17 elements.

halogen	first electron affinity/ (kJ/mol)
F	-328
Cl	-349
Br	-324
I	-295

Table 2

- (a) (i) Use the information in Table 2 to sketch an energy profile diagram when a fluorine atom gains an electron to form a fluoride ion. [3]

Label E_a and ΔH in your energy profile diagram.

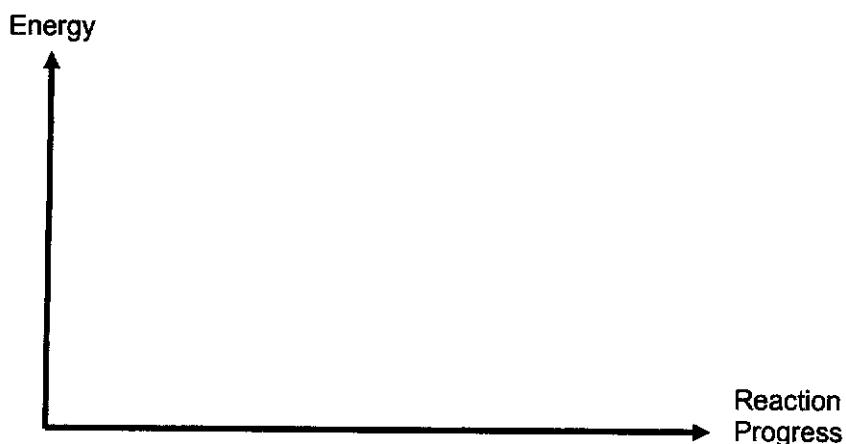

- (ii) From Table 2, state the general trend observed in the first electron affinities going down Group 17. [1]

- (b) (i) Using Table 1, suggest why the atomic size of the atoms increases down the group and hence use this knowledge to explain the pattern described in (a)(ii). [2]

- (ii) Suggest a value for the atomic radius for iodine, I. [1]

M = _____

- (c) A sample of chlorine gas is bubbled into aqueous sodium iodide.

- (i) What will be observed in this reaction? [1]

(ii) Explain your observations.

[2]

Support your answer with a suitable ionic equation.

[Total: 10 marks]

ANSWER KEY



CRESCENT GIRLS' SCHOOL
SECONDARY FOUR
PRELIMINARY EXAMINATION 2024

CHEMISTRY

Paper 1 Multiple Choice

Additional Materials: Multiple Choice Answer Sheet

6092/01

28 August 024

1 hour

READ THESE INSTRUCTIONS FIRST

Write in soft pencil.

Do not use staples, paper clips, highlighters, glue or correction fluids.

Write your name, index number and class on the Answer Sheet in the spaces provided.

DO NOT WRITE ON ANY BARCODES.

There are **forty** questions on this paper. Answer **all** questions. For each question, there are four possible answers, **A, B, C** and **D**.

Choose the **one** you consider correct and record your choice in **soft pencil** on the OTAS sheet.

Read the instructions on the Answer Sheet very carefully.

Each correct answer will score one mark. A mark will not be deducted for a wrong answer.

Any rough working should be done in this booklet

A copy of the Periodic Table is printed on **page 19**.

The use of an approved scientific calculator is expected, where appropriate.

This booklet consists of 19 printed pages, including the cover page.

1	2	3	4	5	6	7	8	9	10
B	C	D	C	A	C	B	A	D	B
11	12	13	14	15	16	17	18	19	20
C	A	D	A	C	D	C	C	A	B
21	22	23	24	25	26	27	28	29	30
C	A	D	C	B	B	A	D	A	B
31	32	33	34	35	36	37	38	39	40
C	D	A	A	B	C	C	B	B	C

- 1 A student measures the rate of the reaction between marble chips, CaCO_3 , and dilute hydrochloric acid.



Which diagrams show apparatus that are suitable for this experiment?

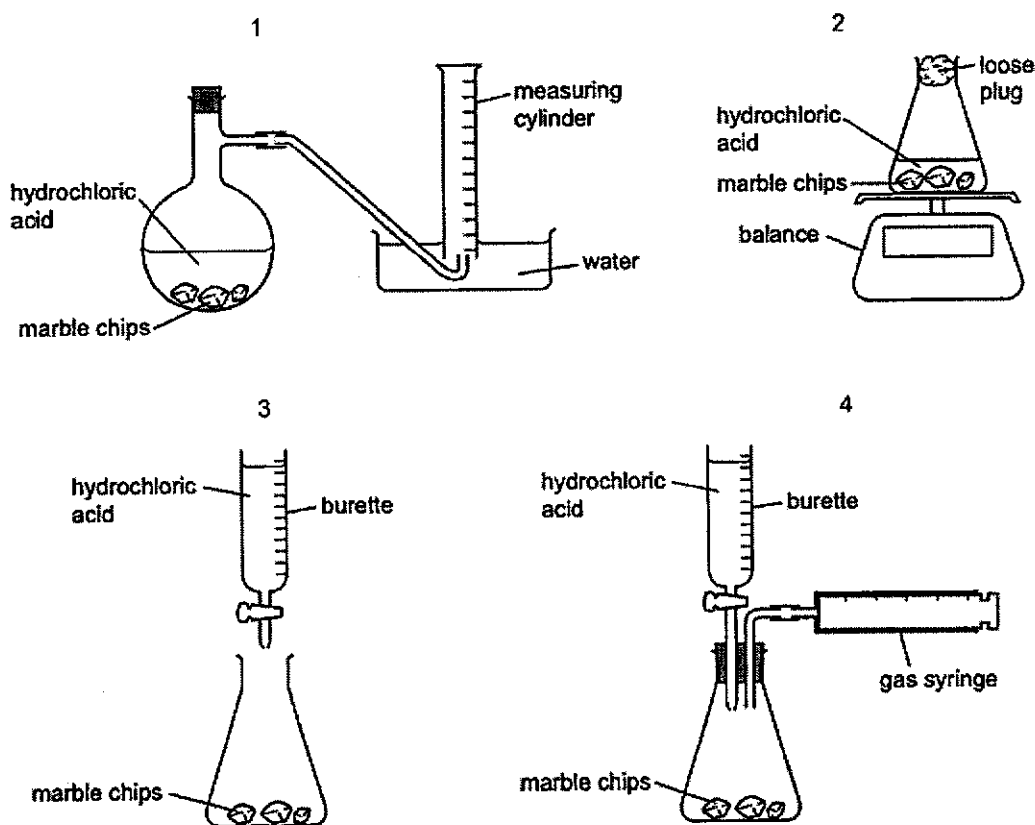

- A** 1 and 2
B 1, 2 and 4
C 2 and 3
D 2, 3 and 4

- 2 Chromatograms of a urine sample using two different solvents are shown below.

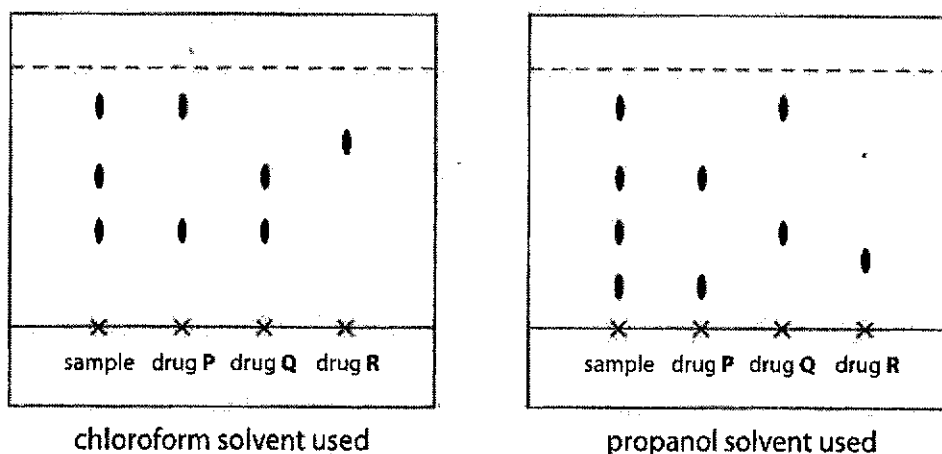

Based on the two chromatograms, which drug(s) is/are present in the urine sample?

- A drug P only
 B drug Q only
 C **drugs P and Q only**
 D drugs P, Q and R
- 3 Since the discovery of graphite, scientists have been able to extract a single layer of carbon atoms (known as graphene) and convert it to another material known as graphane by attaching one hydrogen atom to each carbon atom as shown below.

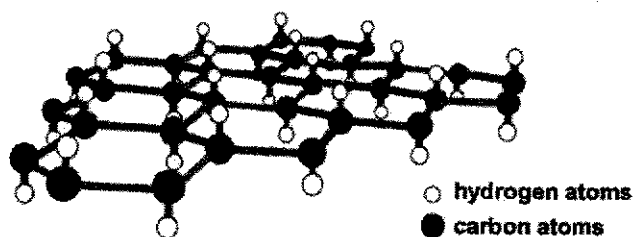

Graphane has the same hexagonal-ring structure as graphene and retains most of its properties too. Which properties of graphene is not likely to be shared by graphane?

- A It is insoluble in water.
 B It is very strong.
 C It has a high melting point.
 D **It is an electrical conductor.**

- 7 The diagram below shows the bonding between P and Q in the covalent molecule, PQ₂.

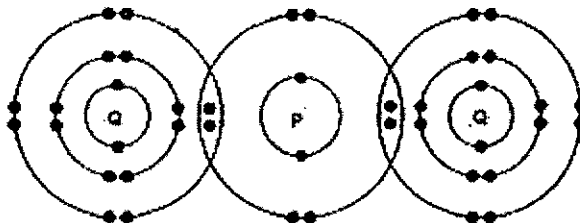

What are the electronic structures of atoms P and Q before combining together to form the above molecule?

	P	Q
A	2.8	2.8.8
B	2.6	2.8.7
C	2.6	2.8.6
D	2.4	2.8.7

- 8 0.1 mole of a chloride XCl₂ combines with 10.8 g of water to form the hydrated salt, XCl₂.nH₂O. What is the value of n?
- A 6 B 8
C 10 D 12
- 9 Ammonia reacts with chlorine according to the equation shown below:

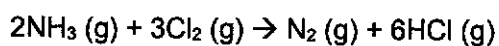

If 90 cm³ of ammonia is mixed with 60 cm³ of Cl₂ and all the volumes were measured at room temperature and pressure, what is the total volume of gases at the end of the reaction?

- A 20 cm³
B 120 cm³
C 140 cm³
D 190 cm³

- 10 When 4.8g of magnesium is heated in a crucible, 5.9g of magnesium oxide is formed.

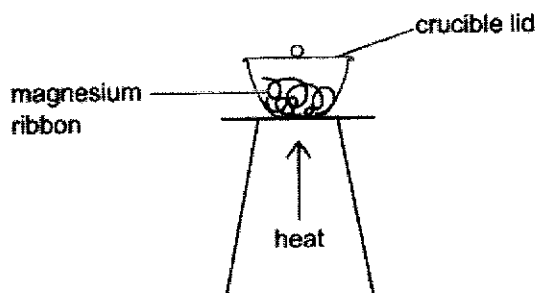

What is the percentage yield of magnesium oxide?

- A 53% B 74% C 80% D 81%
- 11 A student is given two samples, one of which is aluminium oxide and the other is magnesium carbonate. He needs to find a method to identify the two samples.

Which of the following show(s) the correct method(s) and observation(s)?

	method	observation(s)
1	add nitric acid	only aluminium oxide dissolves
2	add nitric acid	both samples dissolve. Effervescence is observed in the reaction with magnesium carbonate
3	add sodium hydroxide	only aluminium oxide dissolves
4	add sodium hydroxide	both samples dissolve. Effervescence is observed in both the reactions

- A 1 and 4 only
 B 2 only
 C 2 and 3 only
 D 3 only

- 12 Butterfly pea flower extract is commonly used in drinks nowadays and it changes colour according to different pH values. The table below shows the colours of butterfly pea flower extract at different pH values.

pH range	colour
0 – 3	violet
4 – 8	blue
9 – 11	green
12 – 14	yellow

Which pair of substances can be distinguished by adding butterfly pea flower extract to each substance separately?

- A** acid rain and aqueous sodium chloride
B aqueous ammonia and limewater
C aqueous sodium sulfate and aqueous sodium chloride
D dilute hydrochloric acid and dilute sulfuric acid
- 13 Which of the following reactions will produce the least amount of carbon dioxide?
- A** sodium carbonate and hydrochloric acid
B copper(II) carbonate and hydrochloric acid
C magnesium carbonate and sulfuric acid
D lead(II) carbonate and sulfuric acid

- 14 The table below shows the results of some tests carried out on separate portions of a solution M.

test	observation
aqueous sodium hydroxide added	test-tube feels warm and no precipitate forms
acidified aqueous silver nitrate added	white precipitate forms

What could be the identity of solution M?

- A** hydrochloric acid
B potassium sulfate
C sodium chloride
D zinc sulfate

- 15 A student stated that since low temperatures produce a greater yield of ammonia, the reaction should be carried out at 50°C instead of 450°C.

Which of the following statements best explains why the reaction is **not** carried out at 50°C?

- A Ammonia is unstable at 50°C.
 B The reactants are unstable at 50°C.
 C **The reaction is too slow at 50°C.**
 D The reaction mixture is easily separated at higher temperatures.

- 16 Ammonium chloride is heated strongly in a boiling tube. Damp blue and red litmus papers were placed at the mouth of the boiling tube for the gases produced.

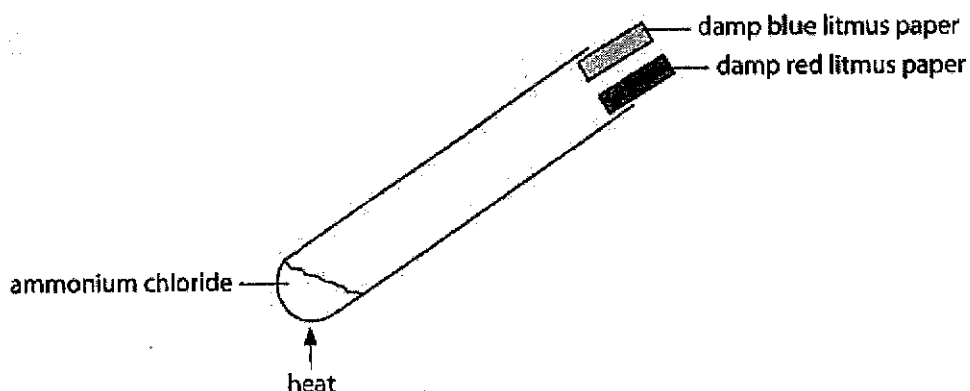

Which of the following is the correct sequence of observations that would be made?

	first observed colour change	final colour of both litmus papers
A	The damp blue litmus paper turns red.	red
B	The damp blue litmus paper turns red then bleaches.	white
C	The damp red litmus paper turns blue.	blue
D	The damp red litmus paper turns blue.	red

- 17 Which are redox reactions?

- 1 $\text{HCl} + \text{NaOH} \rightarrow \text{NaCl} + \text{H}_2\text{O}$
- 2 $\text{Zn} + 2\text{HNO}_3 \rightarrow \text{Zn}(\text{NO}_3)_2 + \text{H}_2$
- 3 $\text{Ag}_2\text{SO}_4 + 2\text{NaCl} \rightarrow 2\text{AgCl} + \text{Na}_2\text{SO}_4$
- 4 $2\text{Fe}^{2+} + \text{Cl}_2 \rightarrow 2\text{Fe}^{3+} + 2\text{Cl}^-$

- A 1, 2 and 3 B 1 and 3
 C **2 and 4** D 3 and 4

- 18 Dry hydrogen gas is passed over a heated powdered solid and then through a cooled U-tube before the excess of hydrogen is burned in air.

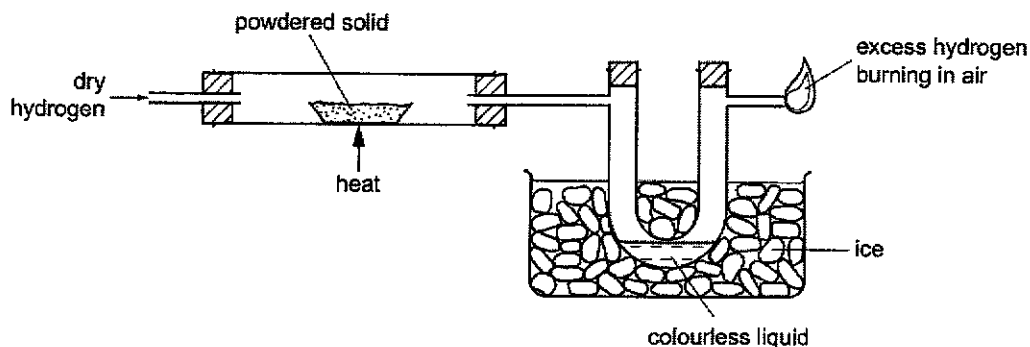

A colourless liquid collects in the U-tube. What could the powdered solid be?

- A aluminium oxide
 B copper(II) oxide
 C iron(III) oxide
 D magnesium oxide
- 19 Equal masses of different metals 1 to 4 are placed in the test tubes containing an equal volume of hydrochloric acid of equal concentration. The thermometers show the maximum temperature recorded for the reaction. (The room temperature is 25 °C.)

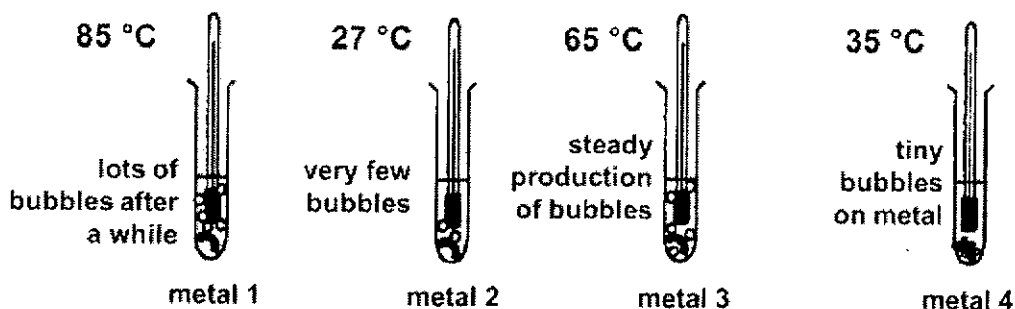

Which of the following statements is/are most likely to be true?

- I Metal 3 will displace metals 2 and 4 from their aqueous salt solutions.
 II Metal 2 can likely be extracted by chemical reduction of its oxide by carbon.
 III Metal 1 is likely to be obtained by electrolysis of its molten chloride.

- A I, and II only
 B I and III only
 C I, II and III
 D II and III only

- 20 The energy diagram represents a chemical reaction carried out both with a catalyst and without a catalyst.

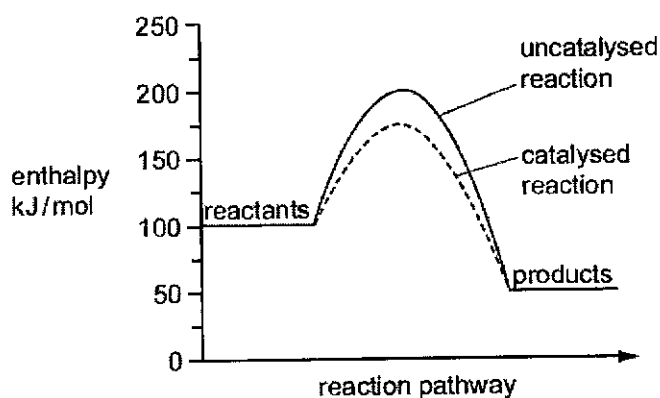

What is the enthalpy change for the catalysed reaction?

- A - 125 kJ/mol
 B - 50 kJ/mol
 C + 75 kJ/mol
 D + 100 kJ/mol
- 21 Hydrogen peroxide reacts with potassium iodide in the presence of dilute acid to produce iodine molecules as shown in the equation below.

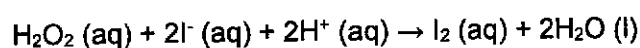

Which factor would **not** affect the rate of this reaction?

- A Concentration of hydrogen peroxide
 B Concentration of potassium iodide
 C Pressure of the reacting vessel
 D Temperature of the reacting vessel and its surroundings

- 22 In the graph shown, curve 1 was obtained by the decomposition of 100 cm³ of 1.0 mol/dm³ hydrogen peroxide solution with manganese(IV) oxide as the catalyst.

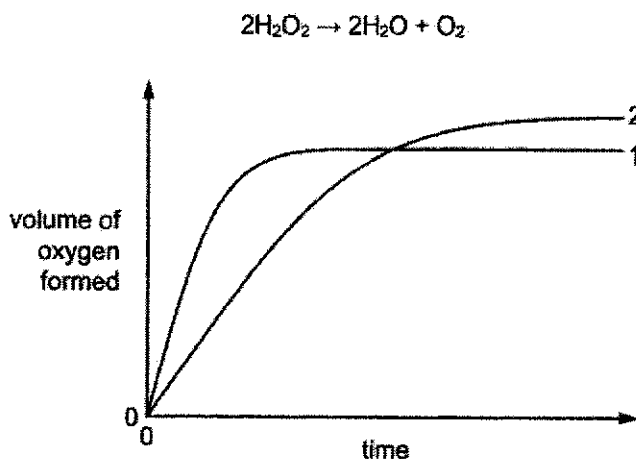

Which change to the original experimental conditions would produce curve 2?

- A** adding some 0.1 mol/dm³ hydrogen peroxide solution
B lowering the temperature
C using a different catalyst
D using less manganese(IV) oxide
- 23 In which of the following set-up will the bulb light up?

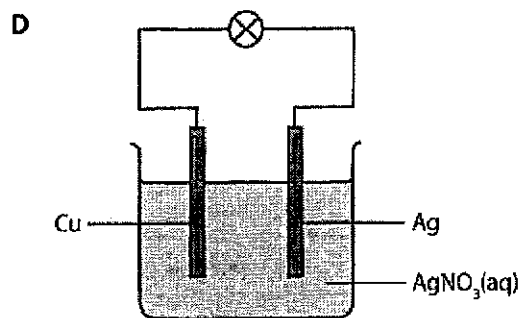
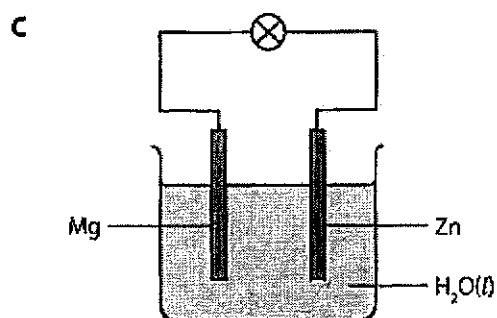
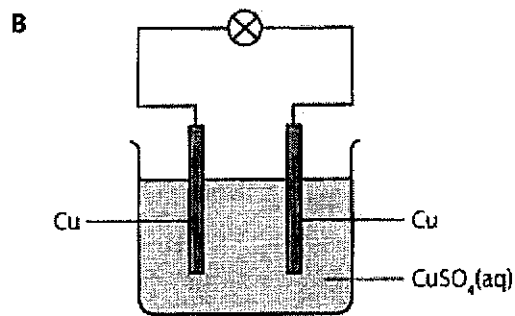
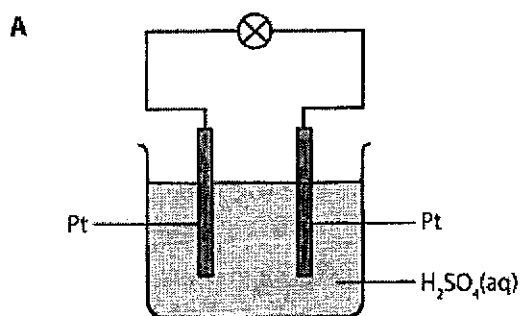

- 24 An electrolysis was carried out on an electrolyte containing X^+ and Y^- ions.

The two equations below show the reactions at the electrodes:

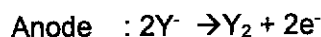
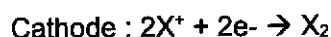

What can the electrolyte be?

- A aqueous magnesium chloride
 B aqueous sodium sulfate
 C concentrated magnesium chloride
 D molten potassium chloride
- 25 In which electrolysis experiment would there be no change in the concentration of the solution?

	<u>electrodes</u>	<u>electrolyte</u>
A	carbon	aqueous copper(II) sulfate
B	copper	aqueous copper(II) sulfate
C	carbon	concentrated potassium chloride
D	platinum	dilute sulfuric acid

- 26 Methane reacts very slowly with air at room temperature. But if a transition metal T is added to the methane-air mixture, the methane ignites quickly.

A student made some statements about the observation.

- I Addition of T reduces the activation energy.
 II Addition of T increases the enthalpy change.
 III Addition of T increases the rate of reaction.
 IV Addition of T reduces the energy of the reactants.

- A I and II only
 B I and III only
 C II and III only
 D All of the above

- 30 Figure below shows the fractional distillation of petroleum.

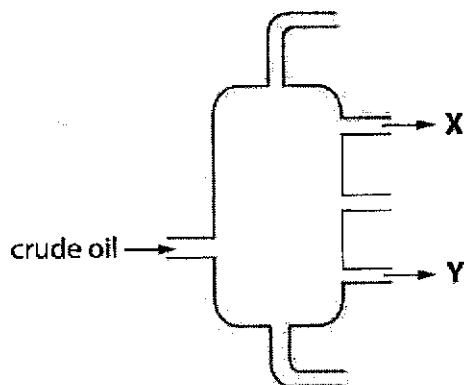

Which of the following statements best describes the fractions at X and Y?

- A The molecules in fraction X contain more carbon atoms than the molecules in fraction Y.
- B The molecules in fraction X are more flammable than the molecules in fraction Y.**
- C The molecules in fraction X are larger than the molecules in fraction Y.
- D The molecules in fraction X have higher boiling points than the molecules in fraction Y.
- 31 An unsaturated hydrocarbon, C_4H_6 reacts with 0.10 mole of hydrogen gas to form the corresponding alkane. What is the mass of C_4H_6 that is required to react with the hydrogen gas completely?
- A 0.90 g
- B 1.80 g
- C 2.70 g**
- D 3.60 g
- 32 Which one of the following shows the correct structural formula and name of the ester formed when methanoic acid reacts with propanol?

	<u>structural formula</u>	<u>name</u>
A	$CH_3CH_2COOCH_3$	methyl propanoate
B	$CH_3CH_2COOCH_3$	propyl methanoate
C	$HCOOCH_2CH_2CH_3$	methyl propanoate
D	$HCOOCH_2CH_2CH_3$	propyl methanoate

33 Which of the following structures are isomers?

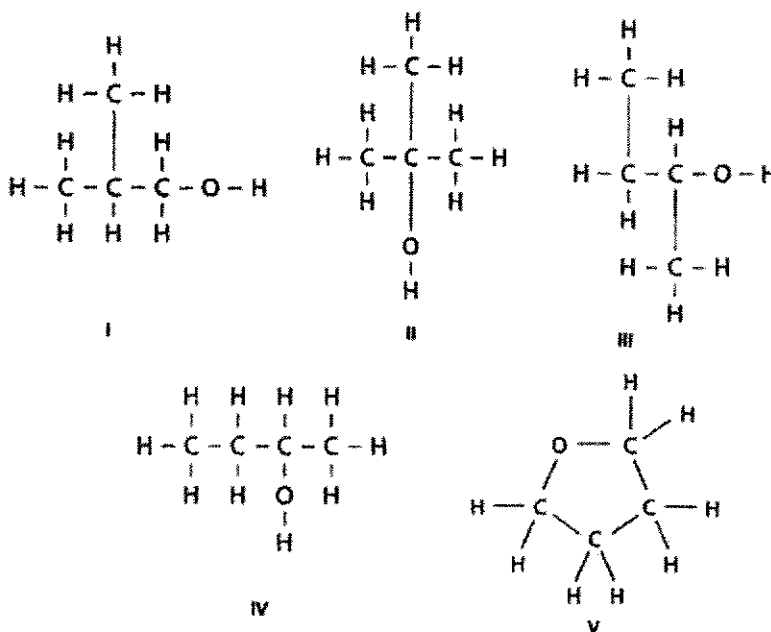

A I, II and IV

B I, II and V

C I, III and IV

D II, III and V

34 Below is a diagram of Cysteine.

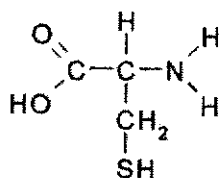

Which one of the following statements about Cysteine is true?

A Effervescence is observed when magnesium metal is added to Cysteine.

B It decolourises acidified potassium manganate(VII).

C It forms a polymer with the same linkage as Terylene.

D It forms an addition polymer with other units of Cysteine.

- 35 An organic compound M undergoes a 2-stage process to form a compound N of chemical formula: $\text{CH}_3\text{CH}_2\text{CH}_2\text{COOH}$. The reagents and conditions of the 2 reactions are as follows:

stage number	reagents	conditions
1	steam	300°C 65 atm Phosphoric acid
2	acidified potassium manganate(VII)	heat under reflux

Which of the following can be a possible structural formula of compound M?

- A butane
 B butene
 C propane
 D propene
- 36 Which of the following is true of an addition polymer and a condensation polymer?
- A Addition polymers are formed from alkenes while condensation polymers are formed from alkanes.
 B Addition polymers produce water as a by-product whereas condensation polymers do not produce any by-products.
 C Condensation polymers could produce water as a by-product whereas addition polymers do not produce any by-product.
 D Nylon is an example of an addition polymer where terylene is an example of a condensation polymer.

- 37 Kevlar is a polymer with high tensile strength, which is five times greater than steel. It is a lightweight and strong fibre with many applications ranging from being used in bulletproof vests to tires. It has the structure below.

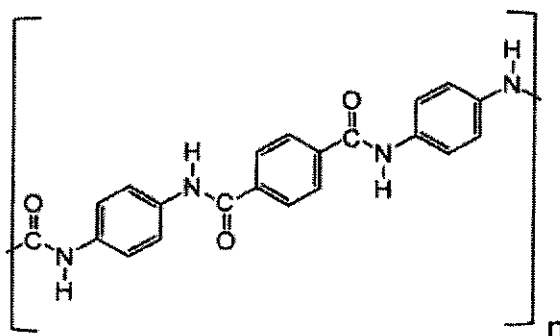

Which could be the monomer(s) for Kevlar?

- A
- B
- C
- D

- 38 To reduce atmospheric pollution, the waste gases from a coal-burning power station are passed through powdered calcium carbonate. Which waste gas will not be removed by the calcium carbonate?

- A carbon dioxide
 B nitrogen monoxide
 C phosphorus(V) oxide
 D sulfur dioxide

39 Which of the following statements are always true of methane and carbon dioxide?

- 1 Both gases can be produced by cows.
- 2 Both gases cause acid rain.
- 3 Methane burns in limited oxygen to produce carbon dioxide.
- 4 They are both greenhouse gases.

- A 1 and 2 only
B 1 and 4 only
C 2 and 3 only
D 3 and 4 only

40 Figure below shows the reaction of zinc in air. When all the grey solid has turned yellow, the source of heat was removed. Upon cooling, the yellow solid turned white.

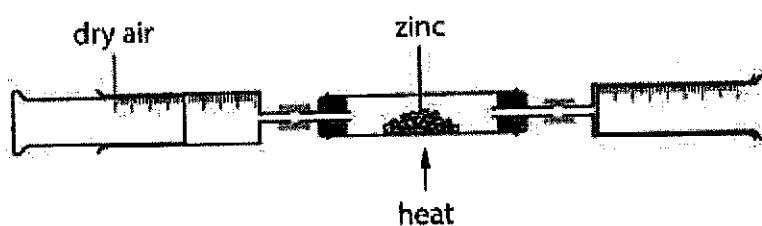

During the reaction, a sample of 250 cm^3 of air was used. What is volume of the remaining air left after the experiment?

- A 52.5 cm^3 B 105 cm^3
C 197.5 cm^3 D 395 cm^3

The Periodic Table of Elements

		Group															
1	2	3	4	5	6	7	8	9	10	11	12	13	14	15	16	17	18
3 Li lithium 7	4 Be beryllium 9	<div style="border: 1px solid black; padding: 5px; display: inline-block;"> Key proton (atomic) number atomic symbol name relative atomic mass </div>															
11 Na sodium 23	12 Mg magnesium 24																
19 K potassium 39	20 Ca calcium 40	21 Sc scandium 45	22 Ti titanium 48	23 V vanadium 51	24 Cr chromium 52	25 Mn manganese 55	26 Fe iron 56	27 Co cobalt 59	28 Ni nickel 59	29 Cu copper 64	30 Zn zinc 65	31 Ga gallium 70	32 Ge germanium 73	33 As arsenic 75	34 Se selenium 79	35 Br bromine 80	36 Kr krypton 84
37 Rb rubidium 85	38 Sr strontium 88	39 Y yttrium 89	40 Zr zirconium 91	41 Nb niobium 93	42 Mo molybdenum 96	43 Tc technetium —	44 Ru ruthenium 101	45 Rh rhodium 103	46 Pd palladium 106	47 Ag silver 108	48 Cd cadmium 112	49 In indium 115	50 Sn tin 119	51 Sb antimony 122	52 Te tellurium 128	53 I iodine 127	54 Xe xenon 131
55 Cs caesium 133	56 Ba barium 137	57-71 lanthanoids	72 Hf hafnium 178	73 Ta tantalum 181	74 W tungsten 184	75 Re rhenium 186	76 Os osmium 190	77 Ir iridium 192	78 Pt platinum 195	79 Au gold 197	80 Hg mercury 201	81 Tl thallium 204	82 Pb lead 207	83 Bi bismuth 209	84 Po polonium —	85 At astatine —	86 Rn radon —
87 Fr francium —	88 Ra radium —	89-103 actinoids	104 Rf rutherfordium —	105 Db dubnium —	106 Sg seaborgium —	107 Bh bohrium —	108 Hs hassium —	109 Mt meitnerium —	110 Ds darmstadtium —	111 Rg roentgenium —	112 Cn copernicium —	113 Nh nihonium —	114 Fl flerovium —	115 Mc moscovium —	116 Lv livermorium —	117 Ts tennessine —	118 Og oganesson —
lanthanoids		57 La lanthanum 139	58 Ce cerium 140	59 Pr praseodymium 141	60 Nd neodymium 144	61 Pm promethium —	62 Sm samarium 150	63 Eu europium 152	64 Gd gadolinium 157	65 Tb terbium 159	66 Dy dysprosium 163	67 Ho holmium 165	68 Er erbium 167	69 Tm thulium 169	70 Yb ytterbium 173	71 Lu lutetium 175	
actinoids		89 Ac actinium —	90 Th thorium 232	91 Pa protactinium 231	92 U uranium 238	93 Np neptunium —	94 Pu plutonium —	95 Am americium —	96 Cm curium —	97 Bk berkelium —	98 Cf californium —	99 Es einsteinium —	100 Fm fermium —	101 Md mendelevium —	102 No nobelium —	103 Lr lawrencium —	

The volume of one mole of any gas is 24 dm³ at room temperature and pressure (r.t.p.).
 The Avogadro constant, $L = 6.02 \times 10^{23} \text{ mol}^{-1}$.

Class:	Register No:	Name:														
 <p style="margin: 0;">CRESCENT GIRLS' SCHOOL SECONDARY FOUR PRELIMINARY EXAMINATION 2024</p>																
CHEMISTRY Paper 2	6092/02 23 August 2024 1 hr 45 mins															
READ THESE INSTRUCTIONS FIRST																
<p>Candidates answer on the Question Paper. No Additional Materials are required. Write your name, index number and class in the spaces provided at the top of this page. Write in dark blue or black pen. You may use an HB pencil for any diagrams or graph. Do not use staples, paper clips, and glue or correction fluid.</p> <p>Section A (70 Marks) Answer all questions Write your answers in the spaces provided</p> <p>Answer one question. Write your answers in the spaces provided. Answer one question. Write your answers in the spaces provided.</p> <p>The number of marks is given in brackets [] at the end of each question or part question. A copy of the Periodic Table is printed on page 23.</p> <p>The use of an approved scientific calculator is expected, where appropriate.</p>																
<table border="1" style="border-collapse: collapse; width: 100%;"> <tr> <th colspan="3" style="padding: 5px;">For Examiner's Use</th> </tr> <tr> <td style="width: 30%; padding: 5px;">Section A</td> <td colspan="2" style="width: 70%;"></td> </tr> <tr> <td style="padding: 5px;">Section B</td> <td colspan="2"></td> </tr> <tr> <td rowspan="2" style="padding: 5px;">Deductions</td> <td style="padding: 5px;">Significant Figures</td> <td style="width: 20%;"></td> </tr> <tr> <td style="padding: 5px;">Units</td> <td></td> </tr> </table>			For Examiner's Use			Section A			Section B			Deductions	Significant Figures		Units	
For Examiner's Use																
Section A																
Section B																
Deductions	Significant Figures															
	Units															

This paper consists of **22** printed pages including the cover page.

Section A

Answer all questions in this section in the spaces provided.
The total mark for this section is 70.

- A1** The figure below shows 'dot-and-cross' diagrams for molecules that contain elements from the first two periods of the Periodic Table. The elements are represented by the letters **M**, **Q**, **R**, **T** and **Z**.

Each diagram shows outer electrons only.

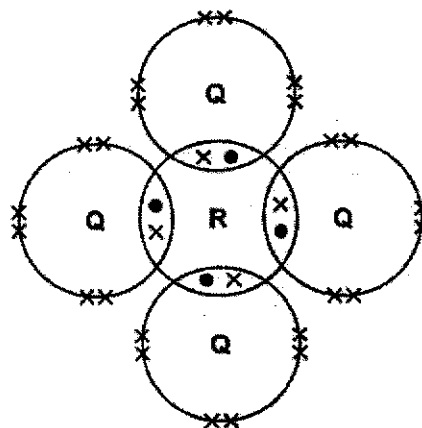
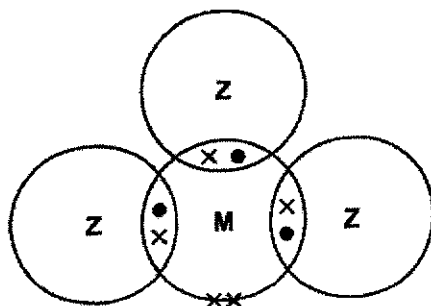
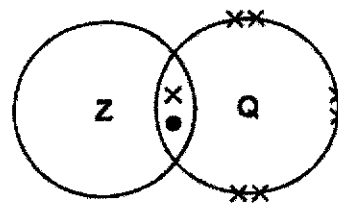
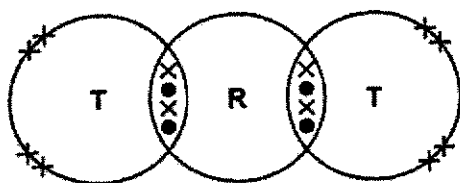

Use the letters **M**, **Q**, **R**, **T** and **Z** to answer the questions below.

- (a) Which element can form an ion with a charge of 1-? [1]
Q or Z
- (b) Which element can gain, lose and share electrons? [1]
Z
- (c) Which element can form an acidic oxide? [1]
M or Q or R
- (d) Which element forms a triple covalent bond? [1]
M

- (e) (i) Potassium reacts with element T to form a compound. [2]

Draw a dot-and-cross diagram of the compound formed between potassium and element T. Show only the valence electrons.



Correct charge – [1], correct ratio – [1]

- (ii) State one physical property of the above compound and explain the reason for the physical property. [2]

High mp/bp (✓) – strong electrostatic FOA between oppositely charged ions (✓) and hence large amount of energy (✓) to overcome.

OR

Good electrical conductor (✓) in aqueous/molten (✓) state – ions are mobile (✓) to conduct electricity

OR

Poor electrical conductor (✓) in solid (✓) state – ions are in fixed positions (✓) and cannot conduct electricity

3 (✓) – [2], 1 – 2 (✓) – [1]

Allow ecf if the properties match the dot and cross diagram

[Total: 8 marks]

A2 The table below shows information about the preparation of pure samples of some solid salts. [5]

Complete the table by filling in the missing information. Include state symbols with any formulae.

formulae of salt	formulae of reagent 1	formulae of reagent 2	method of preparation
CaCO ₃ (s)	Ca(NO ₃) ₂ , CaCl ₂ (must be aqueous) (✓)	Group I/ammonium carbonate (aq) (✓)	Precipitation (✓)
Ag ₂ SO ₄ (s)	Ag ₂ CO ₃ (s)/ Ag ₂ O (s), AgOH (s) (✓)	H ₂ SO ₄ (aq)	Adding excess solid to acid evaporation and crystallisation
NH ₄ NO ₃ (s)	HNO ₃ (aq)	NH ₃ (aq) (✓)	Titration (✓) evaporation and crystallisation

6(✓) – [5], 5(✓) – [4], 3 – 4 (✓) – [3], 2 (✓) – [2], 1 (✓) – [1]
Formula and state symbols must be correct to be given (✓).

[Total: 5 marks]

A3 Nitrogen dioxide is an acidic oxide. It dissolves in water to form two acids, nitric acid and nitrous acid, HNO₂ in a single reaction

(a) (i) Write a balanced chemical equation for the above reaction. [1]

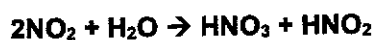

(ii) Disproportionation is a reaction when the same substance is oxidised and reduced in the same reaction. [2]

Explain why the reaction in (a)(i) is a disproportionation reaction.

NO₂ is oxidised as the O.S of N increases from +4 to +5 in HNO₃. [1]

NO₂ is reduced as the O.S of N decreases from +4 to +3 in HNO₂ [1]

(b) One of the main sources of nitrogen monoxide, NO is from the combustion engines of vehicles.

(i) State how nitrogen monoxide, NO is formed in combustion engines of vehicles. [2]

Oxides of nitrogen are formed at **high temperatures** (✓) when **large amount of energy** (✓) is absorbed to break the **N-N triple bonds** (✓) in N_2 .

3 (✓) – [2]; 1 – 2 (✓) – [1]

- (ii) Hence, explain with the aid of a chemical equation how nitrogen monoxide is removed by catalytic converters fitted in cars. [2]

Oxides of nitrogen **react with carbon monoxide to form nitrogen gas and carbon dioxide**. [1]



The amount of air in the pollutant gases that enter the catalytic converter affects the reactions in the converter.

The graph shows the percentage of nitrogen monoxide that the catalytic converter successfully removed.

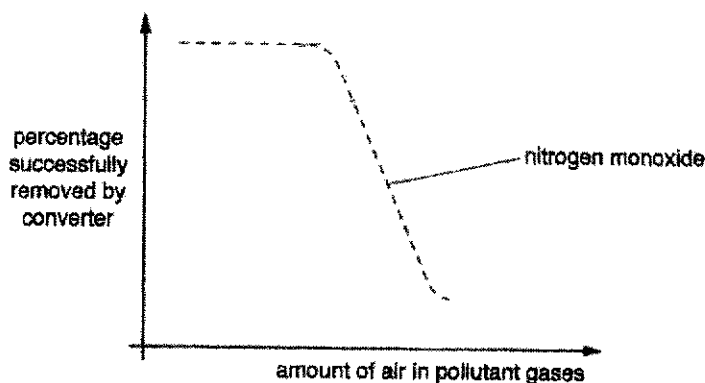

- (iii) Using the equation in (ii) and the graph above, explain why the percentage of nitrogen monoxide successfully removed by catalytic converter decreases as the amount of air increases. [2]

As amount of air increases, carbon monoxide will react with **more oxygen to form carbon dioxide** [1].

Lesser CO present to react with NO [1] and hence lesser NO will be successfully removed from catalytic converter.

[Total: 9 marks]

- A4** A student electrolysed aqueous copper(II) sulfate using two sets-ups shown below. The electrodes used in each set-up are made of the same material. However, the electrodes used in set-ups A and B are made of different materials.

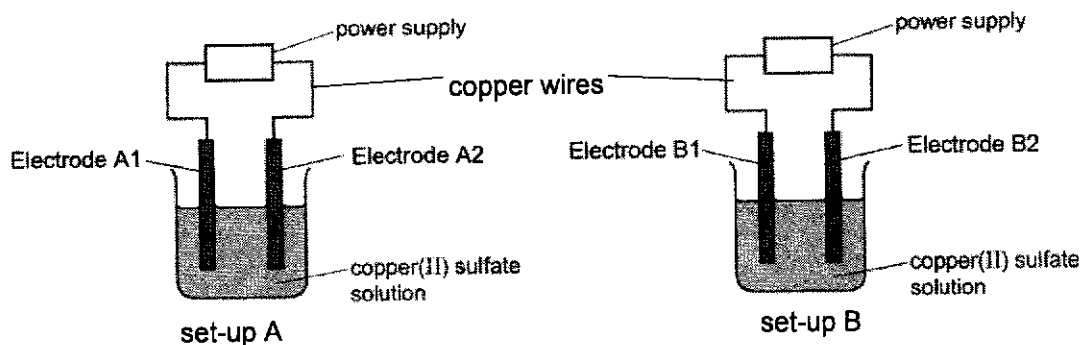

He recorded the following observations in the two set-ups.

set-up A	set-up B
mass of electrode A1 increased	mass of electrode B1 increased
mass of electrode A2 remained the same	mass of electrode B2 decreased
effervescence observed at electrode A2 blue copper(II) sulfate solution fades in colour	no effervescence observed at B2 (blue copper(II) sulfate solution remains unchanged)

- (a) Name the particles which transfer charges through the [1]
- (i) copper wires **electrons**
- (ii) copper(II) sulfate solution **ions** **both (✓) to get [1]**
- (b) State which electrode is the cathode in each set-up.
- Set-up A: **A1** Set-up B: **B1** **both (✓) to get [1]** [1]
- (c) Explain, with an appropriate equation, the increase in mass at electrodes at A1 and B1. [2]

Copper(II) ions gain electrons OR are discharged/reduced preferentially to form copper solid. [1]

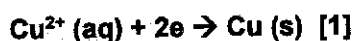

- (d) Write the half-equations of the reactions taking place at Electrode A2 and Electrode B2. [2]

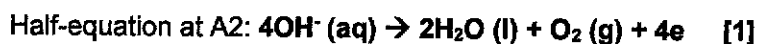

- (e) Describe how the electrolyte of set-up A would change by the end of experiment in terms of its pH and explain why. [2]

Cu^{2+} and OH^- ions are preferentially discharged, leaving behind H^+ ions [1] and hence

pH of solution will become acidic/pH will decrease from pH 7 to below 7 [1].

- (f) Suggest the materials that are used to make the electrodes in [1]

(i) Set-up A: carbon/graphite

(ii) Set-up B: copper

both (✓) to get [1]

[Total: 9 marks]

- A5 The table below shows four different experiments that were conducted with various concentrations and volumes of three different acids that reacted with excess zinc.

experiment	acid	concentration of acid in mol/dm ³	Volume of acid in cm ³
1	hydrochloric acid	0.10	100
2	hydrochloric acid	0.20	100
3	ethanoic acid	0.10	100
4	sulfuric acid	M	N

- (a) The chemical equation between zinc and hydrochloric acid is shown below.

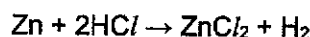

- (i) Find the number of moles of hydrochloric acid that reacted in Experiment 1. [1]

$$\text{No. of moles of acid} = 0.10 \times \frac{100}{1000} = 0.0100 \text{ mol}$$

- (ii) Hence, find the volume of gas that is evolved in Experiment 1. [2]



$$\text{No. of moles of H}_2 = 0.0100 \div 2 = 0.005 \text{ mole [1]}$$

$$\text{Volume of gas} = 0.005 \times 24 \text{ dm}^3 = 0.120 \text{ dm}^3 / 120 \text{ cm}^3 \text{ [1]}$$

No ECF with (ii)

- (iii) The graph below shows the graph for Experiment 1. Label the volume of gas found in (a)(ii) in the axes below. [1]
Hence, sketch the graph for Experiment 2 and label it as Expt 2.

Faster speed and twice the yield [1]

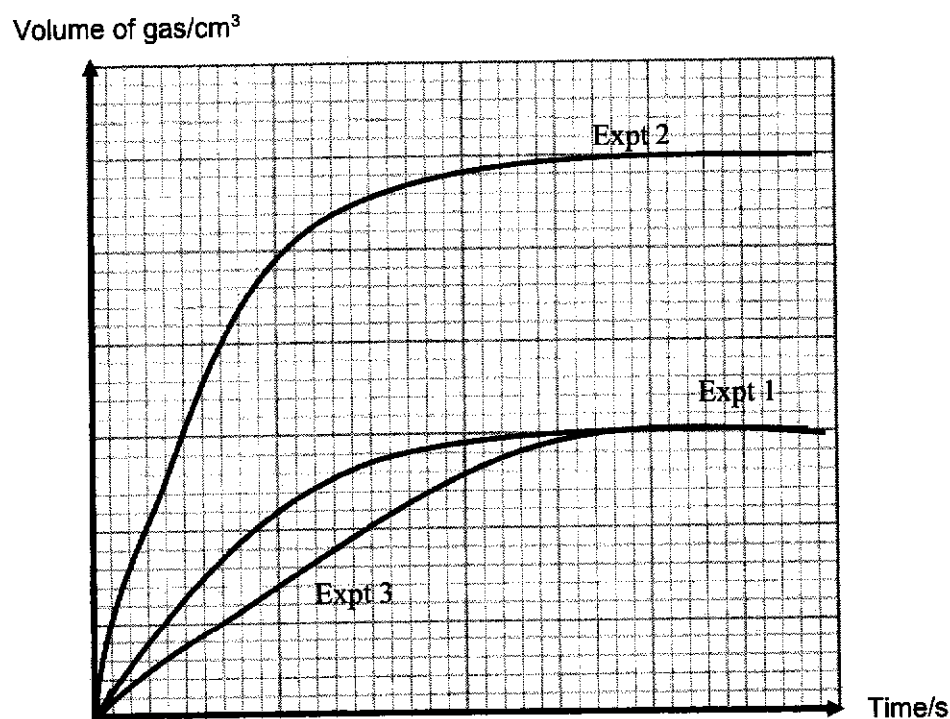

- (b) (i) Write an equation to show the chemical reaction between ethanoic acid and zinc. [1]



- (ii) Hence, sketch the graph for Experiment 3 in the same axes in (a)(iii) and label it as Expt 3. [2]

Slower speed [1]

Same yield [1]

- (iii) Explain the shape of your graph. [3]

Speed of reaction is slower/Graph is less steep than Expt 1 as **ethanoic acid is a weak acid (✓) that dissociates partially in water(✓) to form lower concentration of H⁺ ions. (✓)**

Frequency of effective collisions is lower (✓) and hence speed is slower.
4 (✓) – [2]; 2 – 3 (✓) – [1], 1 (✓) – [0]

Volume of gas formed is the same as Expt 1 as the number of moles of acid used or concentration and volume of acid remains unchanged [1].

- (c) Suggest values for M and N in the table above so that Experiment 4 can have the same graph as Experiment 2. [2]

M: 0.10 mol/dm³ (2dp as per table) [1]
Number of moles of acid must be 0.01 mol.
No units needed.

N: 100 cm³ [1]

[Total: 12 marks]

- A6** Zinc is a transition metal found in Period 4 of the Periodic Table. Some properties of zinc are shown in the table below.

	zinc
electronic configuration	2.8.18.2
melting point/°C	419
density/ g/dm ³	2.99
formula of metal oxide	ZnO
colour of metal chloride	white

It is noted that zinc only forms one oxide and one chloride.

- (a) Using the information from the table, suggest two reasons why zinc is not considered a typical transition metal. [2]

- Has a relatively **low density** of 2.99 g/cm³;
- Has a relatively **low melting point** of 419°C.
- **Does not have variable oxidation states/forms only Zn²⁺** (only forms one chloride / oxide)
- **Does not form coloured compounds** since zinc chloride is white.

Any 2 – [2]

Note : Do not accept zinc has only one charge / has a lower bp or mp than transition metals

(b) A student is given an unknown colourless solution T.

(i) Describe a chemical test that would confirm that solution T contains zinc ions. [2]

Include any observations that you might see.

Add aqueous ammonia (✓) into the solution; [1]

If zinc ions are present, a white precipitate (✓) will form; ppt dissolves in excess aqueous ammonia. (✓) [1]

(ii) To identify the anion present, the student carried out the following test:

step number	procedure
1	Add aqueous barium chloride to a test tube containing solution T.
2	Measure the height of precipitate formed after 5 minutes.
3	Add excess dilute nitric acid to the above mixture.
4	Measure the height of the precipitate formed after 5 minutes.

The results obtained are shown in a graph below.

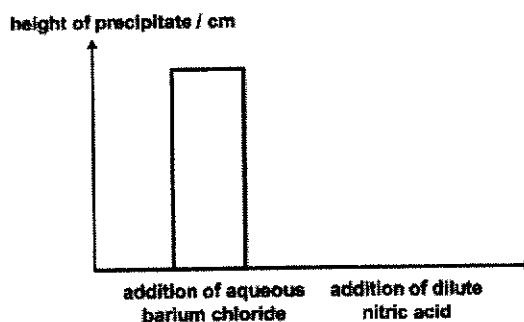

Based on the graph above, the student concluded that the anion is sulfate ion, but not carbonate ion. [3]

Do you agree with the student?

Explain your answer with reference to the graph.

Don't agree with student.

Upon adding of barium chloride, ppt formed could be due to sulfate or carbonate ions. (✓)

Height of ppt decreases/ppt dissolves upon adding nitric acid (✓) and this means that the ppt reacted with nitric acid. (✓)

Hence the ppt could be BaCO_3 , which reacted with acid since BaSO_4 (✓) cannot react with acid.

4 (✓) – [3]; 2 – 3 (✓) – [2], 0 – 1 (✓) – [1]

[Total: 7 marks]

A7 The structures of three organic compounds are given in the table below.

organic compound	structure of compound
W	$ \begin{array}{cccc} & \text{H} & \text{H} & \text{H} & \text{H} \\ & & & & \\ \text{H} & - \text{C} & - \text{C} = & \text{C} & - \text{C} - \text{H} \\ & & & & \\ & \text{H} & & & \text{H} \end{array} $
X	$ \begin{array}{ccccccc} & & \text{O} & & \text{H} & & \text{H} & & \text{O} \\ & & & & & & & & \\ \text{H} & - \text{O} & - \text{C} & - & \text{C} & - & \text{C} & - & \text{C} & - \text{O} - \text{H} \\ & & & & & & & & & \\ & & & & \text{H} & & \text{H} & & & \end{array} $
Y	$ \begin{array}{ccccccc} & & \text{O} & & \text{H} & & \text{H} & & \text{H} \\ & & & & & & & & \\ \text{H} & - \text{O} & - \text{C} & - & \text{C} & - & \text{C} & - & \text{C} & - \text{O} - \text{H} \\ & & & & & & & & \\ & & & & \text{H} & & \text{H} & & \text{H} \end{array} $

- (a) (i) State the compound that can undergo addition polymerisation and condensation polymerisation on its own respectively. [2]

Addition polymerisation: W

Condensation polymerisation: Y

- (ii) Draw two repeat units of the respective addition and condensation polymer. [2]

Addition Polymer:

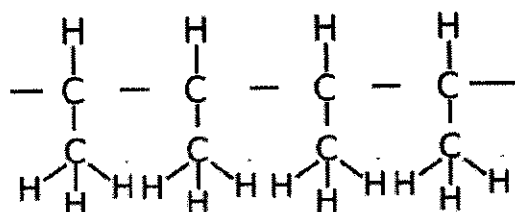

Condensation Polymer:

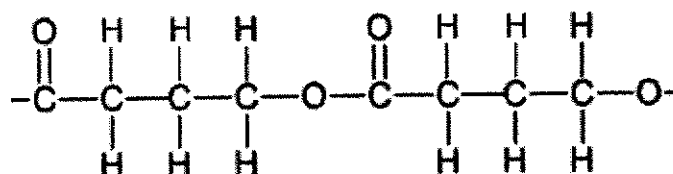

- (b) (i) Draw the structural formula of a simple molecule that can combine with X to undergo condensation polymerisation. [1]

Draw any di-ol or di-amine

(all bonds must be correct and can accept a shape to represent alkyl group)

- (ii) Hence, draw the structure of the polymer formed. [1]

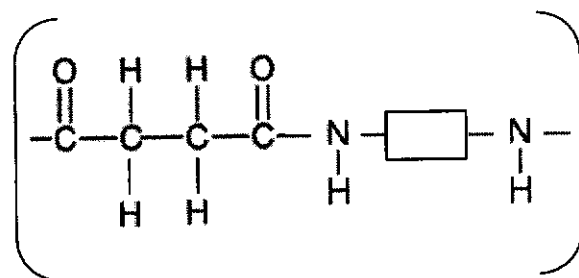

n

Note : Repeat unit is not accepted.

- (iii) Name the small molecule that is formed as a by-product. [1]

water

- (c) (i) Describe a test that can be used to differentiate between organic compounds X and Y. [2]

Heat in (reflux) (✓) both compounds with aqueous acidified potassium manganate(VII) (✓).

Purple solution decolourises with Y (✓) but not with X.

3(✓) – [2]; 1 – 2 (✓) – [1]

- (ii) Name a reagent that can be used to differentiate organic compound W from compounds X and Y. [1]

Aqueous bromine (Note : bromine gas and bromine water are not accepted)

[Total: 10 marks]

- A8** A pH probe attached to a computer measures pH changes during some titration experiments. In experiment 1, 0.1 mol/dm^3 of hydrochloric acid was added from a burette to 25.0 cm^3 of dilute sodium hydroxide. The pH probe measured the pH during the experiment. Graph 1 shows the results.

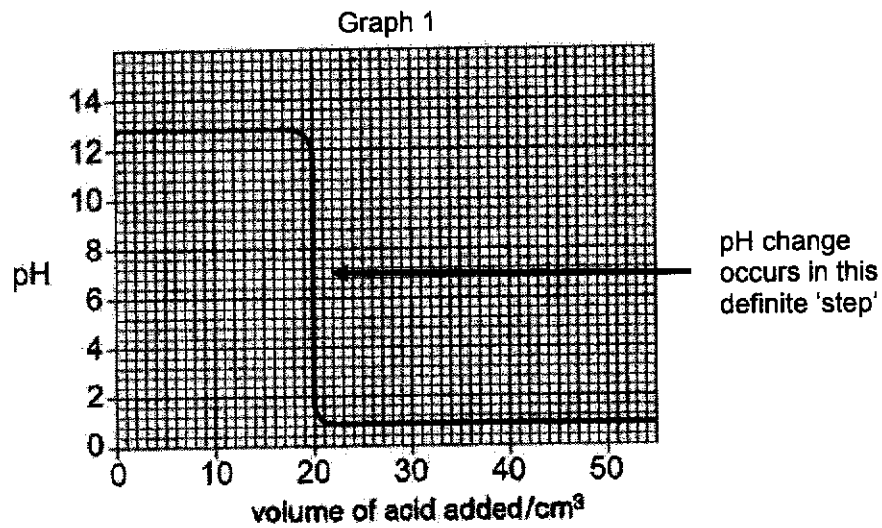

- In experiment 2, 0.1 mol/dm^3 hydrochloric acid was added from a burette to 25.0 cm^3 of dilute sodium carbonate. Graph 2 shows the results.

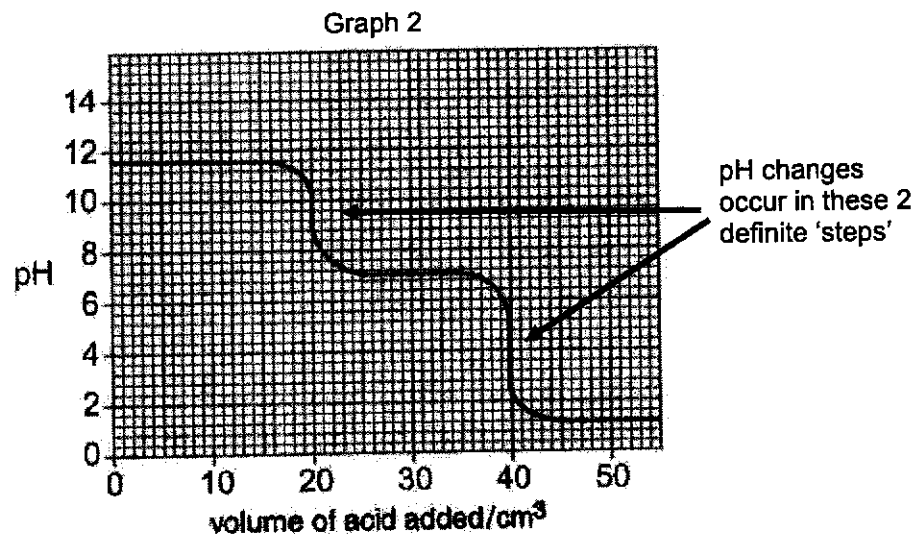

The reaction between sodium carbonate and hydrochloric acid happens in two stages.

Stage 1: Sodium carbonate reacts with dilute hydrochloric acid to form sodium hydrogencarbonate and a neutral salt.

Stage 2: Sodium hydrogencarbonate undergoes a further reaction with hydrochloric acid. An indicator can be used to see when a pH change happens in the definite 'step'.

The diagram shows the colours of some indicators at different pH values. In between the colours, most indicators change colour over a range of pH values.

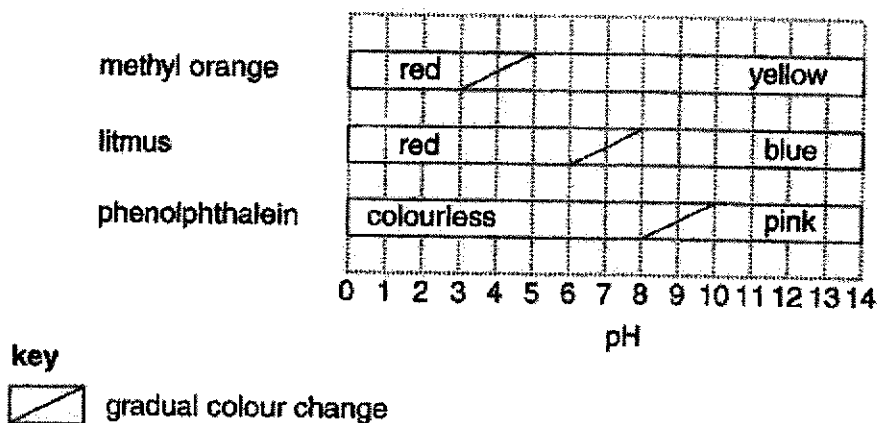

The best indicator for a titration gives a distinct colour change when a 'definite step' occurs.

In Experiment 1, it is found that all three indicators are suitable to give an accurate titration volume.

- (a) Use the information to calculate the concentration of sodium hydroxide used in Experiment 1. [2]

$$\text{No. of moles of acid} = 0.1 \times \frac{20}{1000} = 0.002 \text{ mol} \quad [1]$$

$$\text{No. of moles of NaOH} = 0.002 \text{ mol}$$

$$\text{Concentration of NaOH} = 0.002 \div \frac{25.0}{1000} = 0.08 / 0.0800 \text{ mol/dm}^3 \quad [1]$$

- (b) A third experiment was carried out. A solution of the sodium hydroxide of the same concentration as that used in Experiment 1 was used. [1]

In this experiment, hydrochloric acid of a concentration of 0.20 mol/dm^3 was used.

Using the axes for Graph 1 above, sketch the graph you would expect from this experiment and label it Experiment 3.

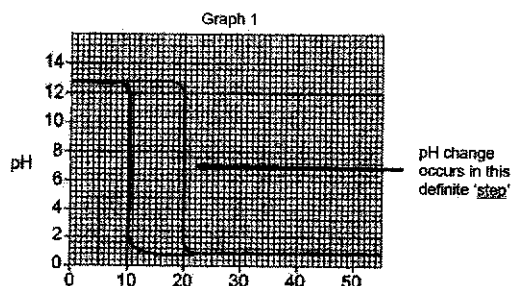

- (c) Identify two differences between the pH graphs for Experiment 1 and 2. [2]

The starting pH of sodium hydroxide is at pH 12.4 while the starting pH of sodium carbonate is 11.6/starting pH of sodium hydroxide in Expt 1 is higher than that of sodium carbonate in Expt 2. [1]

One definite step/one pH drop in Experiment 1 but there are two definite steps/two pH drops in Experiment 2. [1]

- (d) (i) Identify the neutral salt formed in Stage 1 of Experiment 2 [1]

Sodium chloride, NaCl

- (ii) Based on Graph 2, suggest the pH of sodium hydrogencarbonate. [1]

Vertical portion of graph range pH 8.4 – 10.4

- (iii) Using the information from Graph 2, state and explain the indicator that is suitable to find the titration volume for Stage 1 in Experiment 2. [2]

The definite step for stage 1 in Experiment 2 occurs between pH 8 – 10 (✓), Phenolphthalein (✓) is a suitable indicator as the colour change for the indicator is also between pH 8 – 10 (✓) which coincides with the definite step.

3 (✓) – [2]; 1 – 2 (✓) – [1]

- (iv) Write a chemical equation for the reaction in Stage 2 of Experiment 2. [1]

$\text{NaHCO}_3 + \text{HCl} \rightarrow \text{NaCl} + \text{CO}_2 + \text{H}_2\text{O}$

[Total: 10 marks]

Section B (10 Marks)

Answer only ONE question in this section.

EITHER

- B9** Alkynes are a homologous series of hydrocarbons.
The structural formulae of two members of this series are shown below.

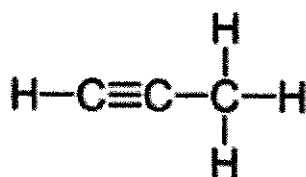

propyne

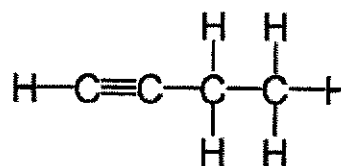

butyne

- (a) What is the functional group of this homologous series? [1]

Deduce the molecular formula of the first member of this homologous series.



- (b) The boiling points of four consecutive members of the alkyne series are shown in the table.

name of alkyne	boiling point/ ^o C
propyne	-23.2
butyne	8.1
pentyne	
hexyne	71.2
heptyne	100

- (i) Predict the boiling point of pentyne and suggest a method to separate a mixture of pentyne and hexyne. [2]

**35°C – 45°C inclusive [1],
fractional distillation [1]**

- (ii) State and explain the trend of the boiling points down the table. [2]

Boiling points increase (✓) down the table as the molecular mass/molecular size /number of carbon atoms increase. (✓)

Strength of intermolecular forces of attractions increases. (✓)

Higher amount of heat energy (✓) required to overcome the IMFOA

4 (✓) – [2]; 2 – 3 (✓) – [1]; 1 (✓) – [0]

- (c) Alkynes can be prepared by reacting a dibromoalkane with potassium hydroxide solution. An equation for the reaction is shown.

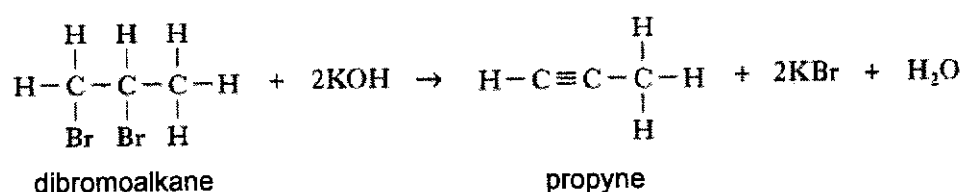

Another dibromoalkane shown below also reacts with potassium hydroxide solution.

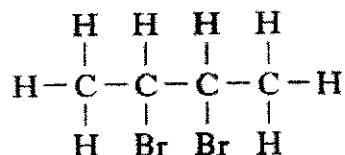

- (i) Draw the full structural formula of the alkyne formed. [1]

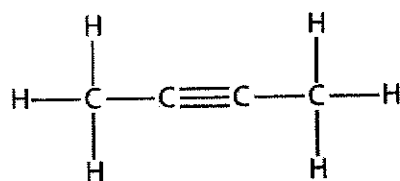

- (ii) Predict whether the dibromoalkane shown below forms an alkyne when it is added to potassium hydroxide solution. Explain your answer. [2]

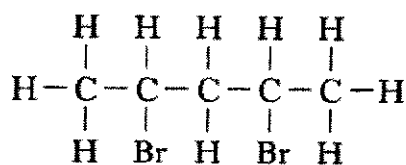

It will not form an alkyne as the two bromine atoms are not on consecutive carbon atoms/ two carbon atoms that are side by side [1]

unable to remove a Br₂ molecule/ 2 bromine atoms [1] to form the C-C triple bond.

- (d) Pentynes are also a member of the alkyne homologous series with 5 carbon atoms. [2]

Draw the full structural formulae of two isomers of pentyne.

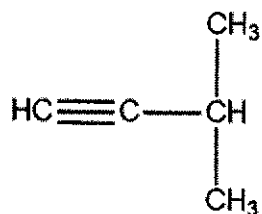
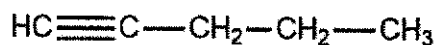

Any acceptable structural formula

[Total: 10 marks]

OR
B9

Fluorine, chlorine, bromine and iodine are elements found in Group 17 of the Periodic Table. Some trends that can be observed as we go down Group 17 are atomic radius and ionic radius.

Table 1 below shows the atomic and ionic radii of halogens.

halogen	atomic radius/ nm	ionic (X ⁻) radius/ nm
F	0.071	0.133
Cl	0.099	0.181
Br	0.114	0.196
I	M	0.220

Table 1

Electron affinity, shown in Table 2 below, is a measure of the attraction between the incoming electron and the nucleus. The first electron affinity is the energy change when 1 mole of gaseous atoms gain an electron to form 1 mole of gaseous ions. The reaction can be shown in an equation below:

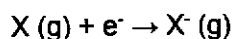

Table 2 shows the first electron affinities of Group 17 elements.

Halogen	first electron affinity/ (kJ/mol)
F	-328
Cl	-349
Br	-324
I	-295

Table 2

- (a) (i) Use the information in Table 2 to sketch an energy profile diagram when a fluorine atom gains an electron to form a fluoride ion. [3]

Label E_a and ΔH in your energy profile diagram.

Energy



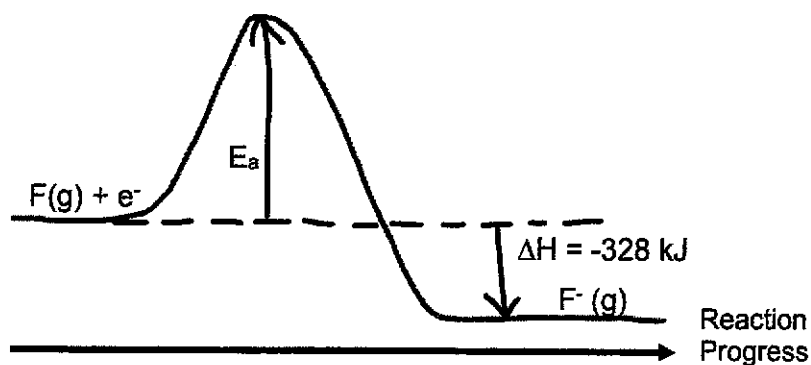

E_a and ΔH – [1], exothermic – [1], reactants and products – [1]

- (ii) From Table 2, state the general trend observed in the first electron affinities going down Group 17. [1]

The electron affinities decrease/less exothermic down the group [1]

- (b) (i) Using Table 1, suggest why the atomic size of the atoms increases down the group and hence use this knowledge to explain the pattern described in (a). [2]

Atomic radius increases /number of electron shells increase down the group. [1]

The attractions between the nucleus and the incoming/valence electron decreases when an atom gains electrons. [1]

- (ii) Suggest a value for the atomic radius for iodine, I. [1]

$M = 0.130 - 0.140$ [1]

- (c) A sample of chlorine gas is bubbled into aqueous sodium iodide.

- (i) What will be observed in this reaction? [1]

Colourless solution turns brown/reddish brown/ black ppt forms. [1]

- (ii) Explain your observations. [2]

Support your answer with a suitable ionic equation.

Chlorine is **more reactive than iodine** (✓) and hence it **displaces iodine** (✓) from sodium iodide. [1]

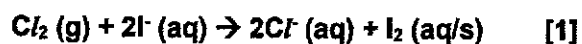

2 (✓) for 1 mark

