

Visit

FREETESTPAPER.com

for more papers



Website: [freetestpaper.com](http://www.freetestpaper.com)



[Facebook.com/freetestpaper](https://www.facebook.com/freetestpaper)



[Twitter.com/freetestpaper](https://www.twitter.com/freetestpaper)

NAME:

NO:

CLASS: 4E1

ADMIRALTY SECONDARY SCHOOL



PRELIMINARY EXAMINATION 2019

SUBJECT : Physics
CODE/PAPER : 6091 / 1
LEVEL/STREAM : Secondary 4 Express
DATE : 3 September 2019
TIME : 1130h – 1230h
DURATION : 1 hour

Instructions to candidates:

Write your Name, Class and Index Number on all the work you hand in.
Do not use staples, paper clips, highlighters, glue or correction fluid.

Answer **all** questions.

For each question there are four possible answers **A, B, C** and **D**.

Choose the **one** you consider correct and record your choice on the OTAS sheet.

	Marks	
Section A		40

DO NOT TURN OVER THIS PAPER UNTIL YOU ARE TOLD TO DO SO.

Answer all questions.

- 1 The diagram below shows two identical spheres placed next to each other.

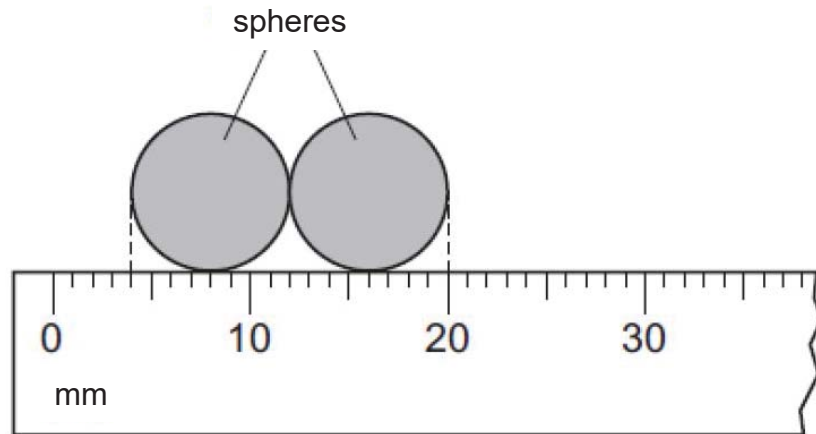

What is the radius of each sphere?

- A 2 mm B 4 mm C 8 mm D 16 mm
- 2 It takes 1.5 s for the pendulum to swing from X to Y.

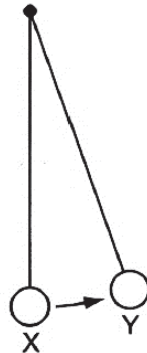

How many complete oscillations are there in 1 minute?

- A 10 B 20 C 40 D 80

3 Which of the following distance–time (d – t) graphs represent deceleration?

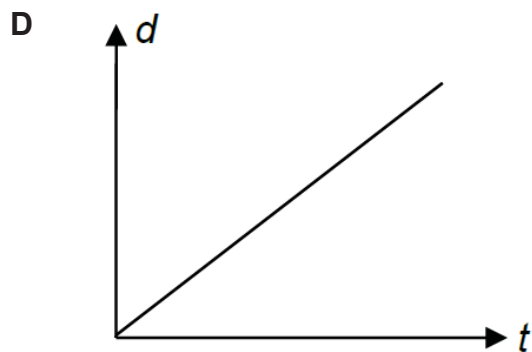
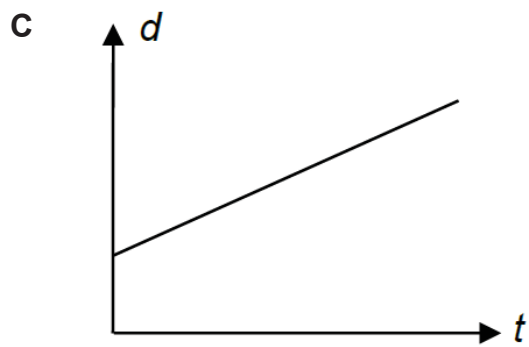
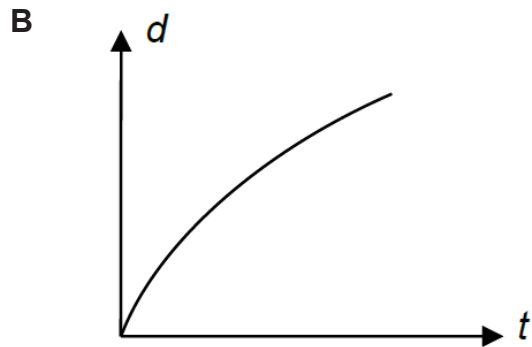
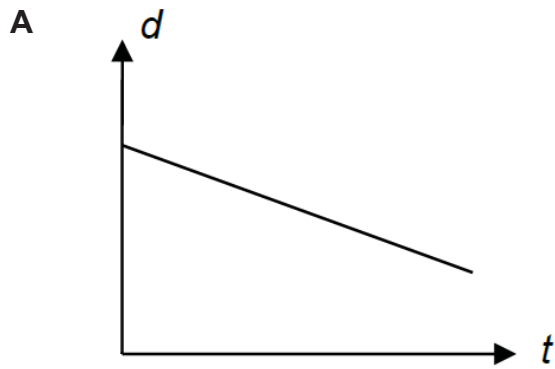

4 A stone is thrown upwards from the top of a building. Which row describes the acceleration and the velocity of the stone when it reaches maximum height?

	acceleration / m/s^2	velocity/ m/s
A	0	0
B	0	10
C	10	0
D	10	10

- 5 An object falls from a height of 120 m. How much time does it take to reach the ground?

A 4.9 s B 10.0 s C 12.0 s D 15.6 s

- 6 The following diagram shows all the horizontal forces acting on a moving truck.

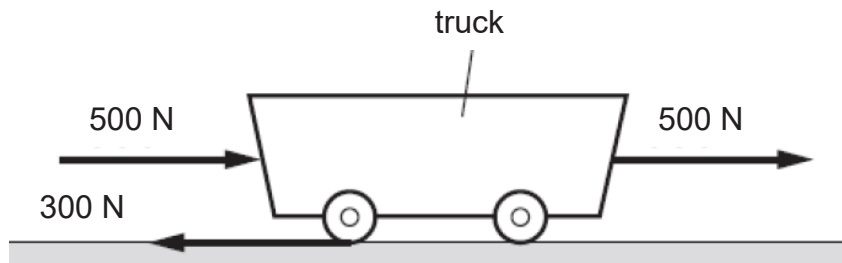

Which of the following best describes the motion of the truck?

- A The truck will stop.
 B The truck will move to the right.
 C The truck will move to the left.
 D The truck will accelerate to the right.
- 7 The diagram below shows how the weight varies with mass on Planets P and Q

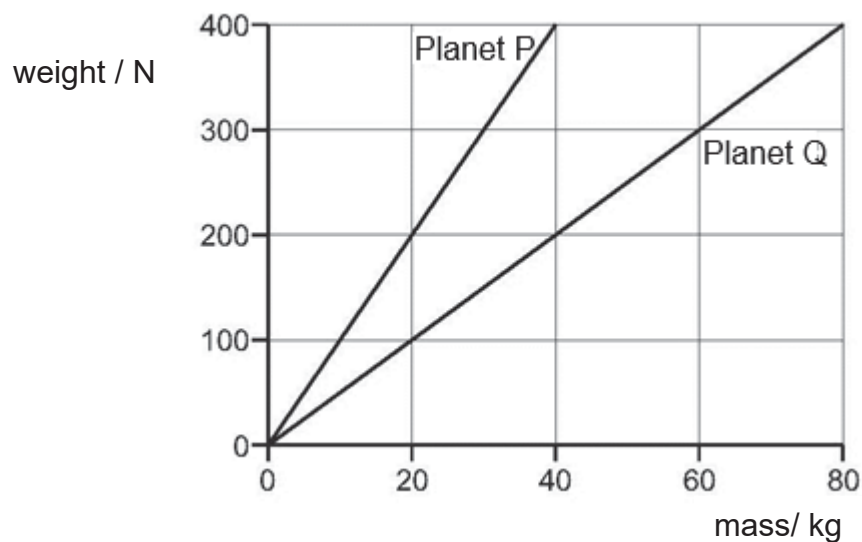

An object weighs 400 N on Planet P. The object is then taken to Planet Q. Which of the following is correct?

	mass of object on Planet Q / kg	weight of object on Planet Q / N
A	40	200
B	40	400
C	80	200
D	80	400

- 8 A small box of mass 2.0 kg moves along a track as shown in the figure. The speeds of the objects at point A and B are 4.0 m/s and 1.0 m/s respectively. The total distance between A and B is 2.5 m.

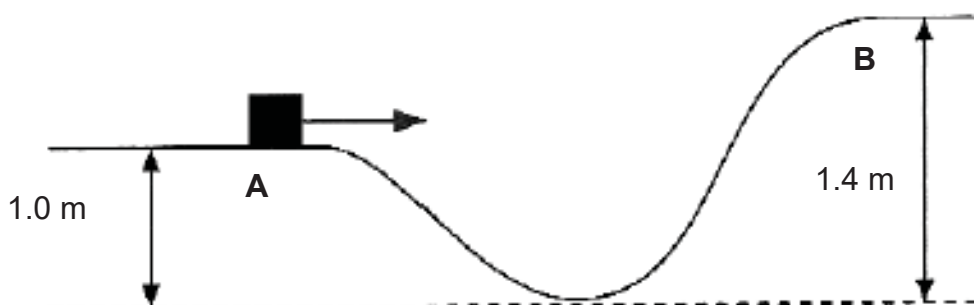

What is the average friction acting on the box as it moves from A to B?

- A 2.8 N B 5.6 N C 6.0 N D 8.0 N
- 9 In the diagram below, the uniform metre rule is pivoted at X and held up at the point Y by a rope.

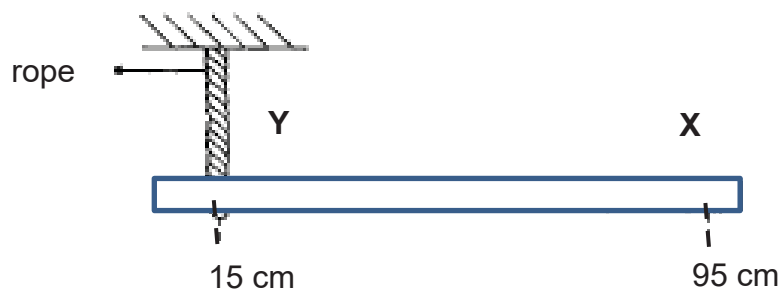

Given that the weight of the metre rule is 4.0 N, calculate the tension in the rope that is needed to ensure that the rule stays horizontal.

- A 1.8 N B 2.3 N C 3.1 N D 5.1 N
- 10 An object is slightly displaced by an external force. When the external force is removed, the object returns to its original position. What state of equilibrium is the object in?
- A stable B neutral C unstable D rotational

- 11 Two blocks are stacked on top of one another on a table.

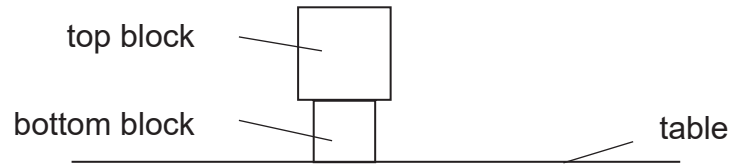

The weight of the top block is Q and the weight of the bottom block is R .
 The base area of top block is X and the base area of bottom block is Y .
 What is the pressure acting on the table by the blocks?

- A $(Q+R)/X$ B $(Q+R)/Y$ C $(Q-R)/X$ D $(Q-R)/Y$
- 12 Four holes, **A**, **B**, **C** and **D** are made on a uniform lamina. The centre of gravity of the lamina is at **G**. Which one of the following shows correctly the lamina hanging freely about each of the holes?

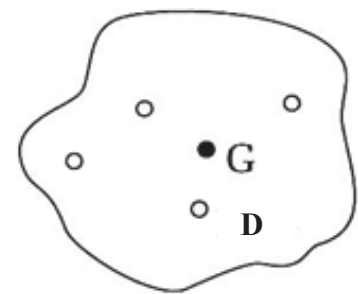
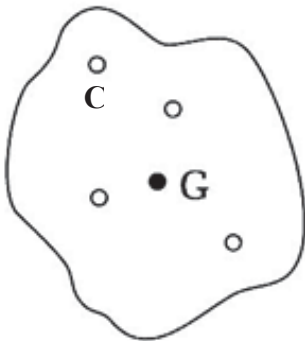
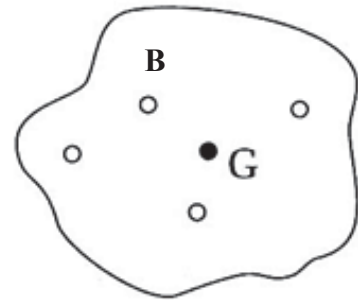
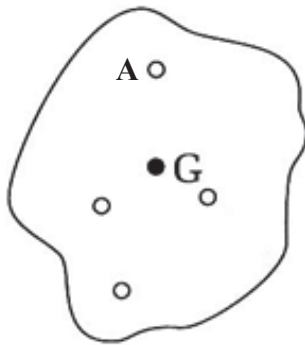

- 13 The diagram shows four containers containing water or oil. Oil floats on water. Which of the container will have the higher pressure at the base of the container?

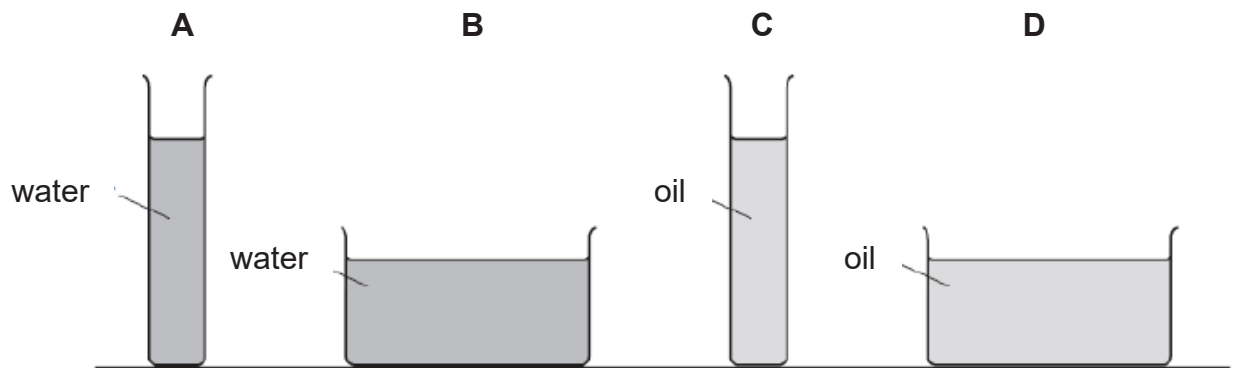

- 14 The diagram below shows a simple hydraulic system, where a 20 N force is acting on piston P. Piston P has an area of 5.0 cm^2 and piston Q has an area of 30.0 cm^2 .

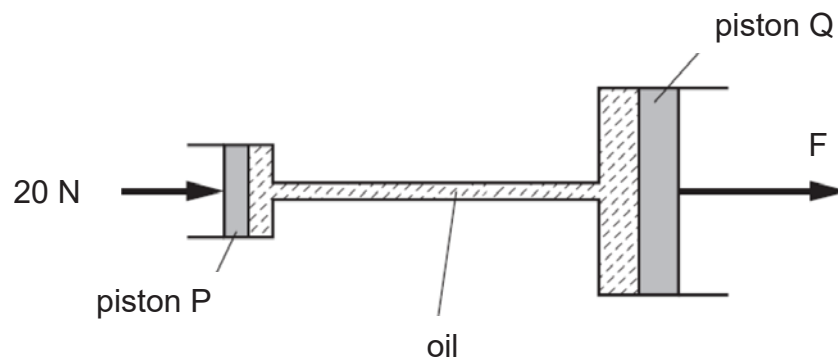

What is the magnitude of force F?

- A 4.0 N B 20 N C 120 N D 3000 N

- 15 A mercury barometer and mercury manometer are placed in the same room placed on a top of a mountain. The manometer is connected to a gas cylinder.

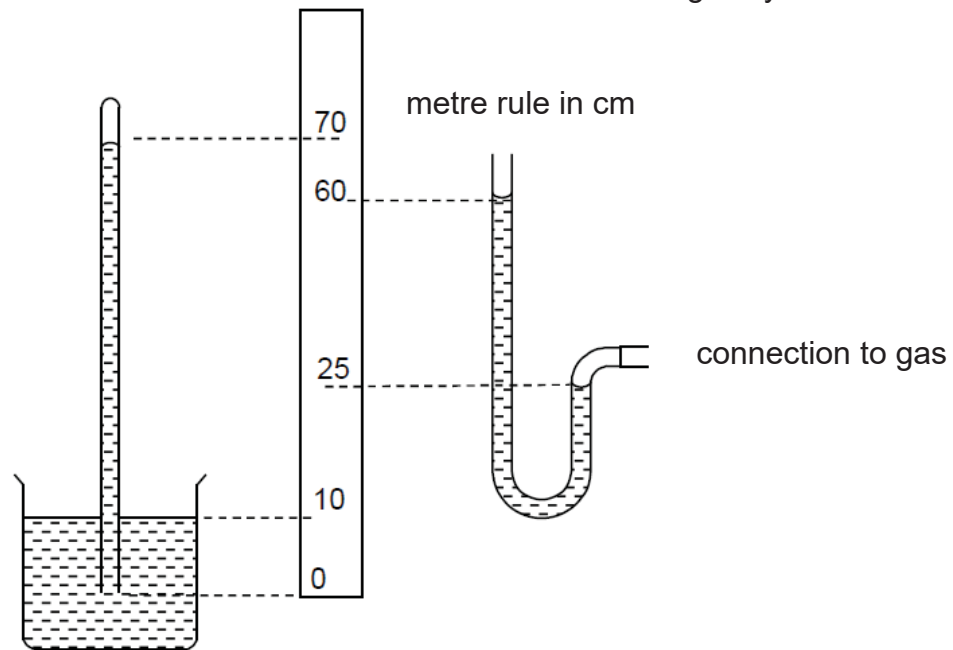

What is the pressure of the gas?

- A 35 cm Hg B 45 cm Hg C 60 cm Hg D 95 cm Hg
- 16 The diagram shows a thermocouple when junction X and Y are placed in melting ice and liquid at 35 °C respectively.

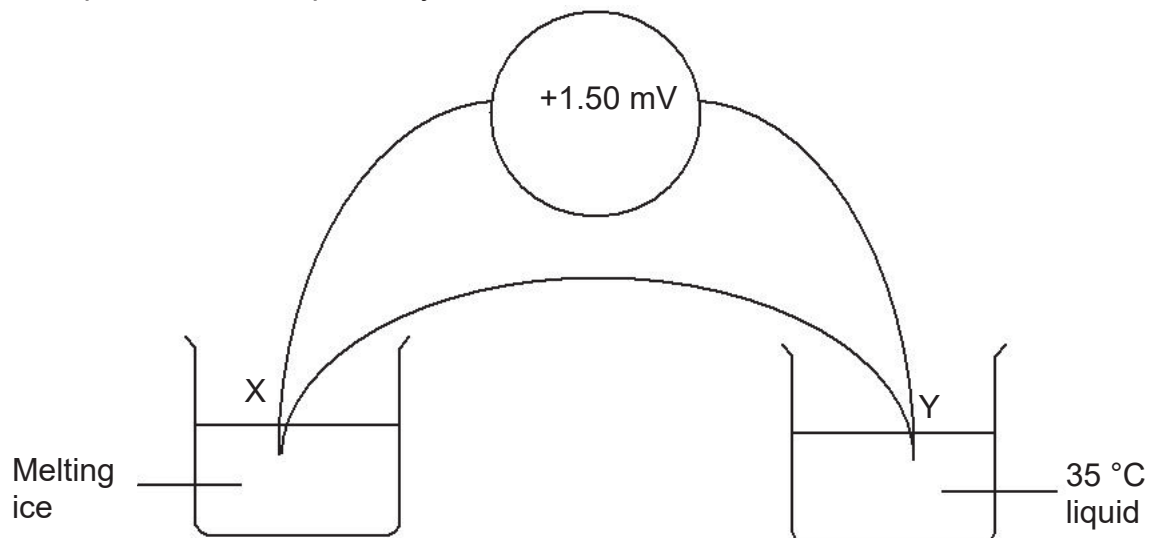

What is the voltmeter reading when junction X is replaced by boiling water at 100 °C?

- A -2.79 mV B -1.92 mV C +1.92 mV D +2.79 mV

- 17 Which diagram represents the change in arrangement of the particles of water when it freezes?

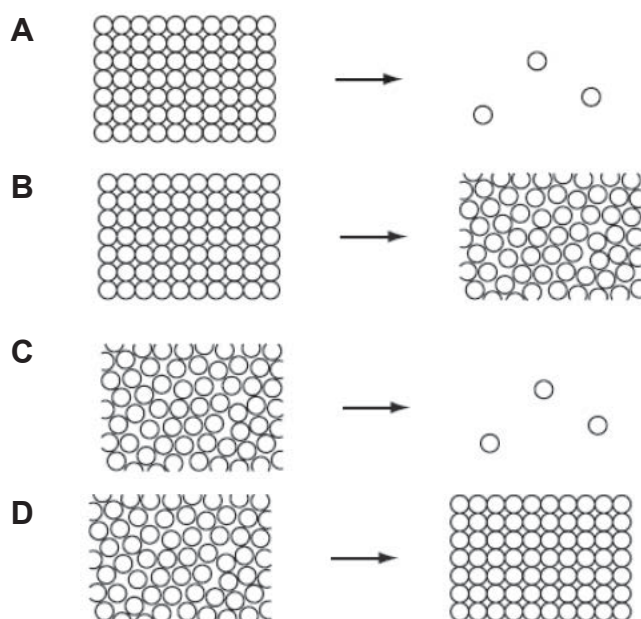

- 18 The diagram shows a container used to keep food warm for delivery.

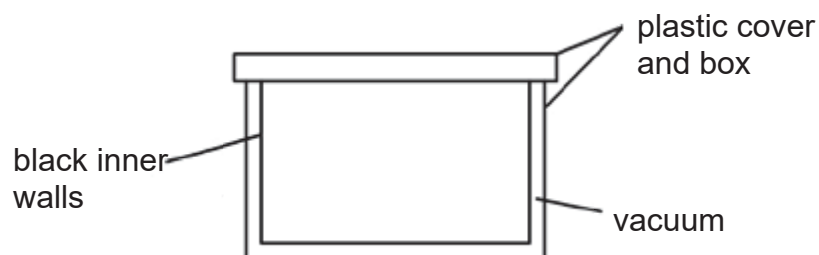

Which of the following explanation is incorrect?

- A Plastic is a poor conductor of heat, hence heat loss will be reduced through conduction.
- B Plastic cover reduces the formation of convection current, preventing the cooling of food contents in the container.
- C Vacuum reduces heat loss due to conduction as it does not have a medium to transfer the heat.
- D Black inner wall is a poor absorber of infra-red radiation, hence does not absorb heat from the food.

- 19 A hot piece of heating rod is immersed into a beaker of water.

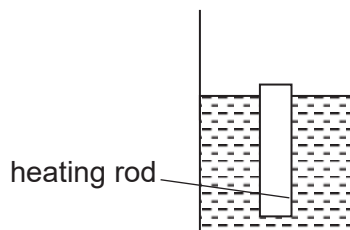

Bubbles are observed in the water at the surface area in contact with the heating rod. Which of the following statement best explains the observation?

- A Conduction of water in contact with the rod causes bubbles to be formed.
 B Convection current caused by the hot rod causes bubbles to be formed.
 C Evaporation of water next to the heating rod causes bubbles to be formed.
 D Radiation to the water cause water to boil, causing bubbles to be formed.
- 20 An electrical heater is used to heat a 2 kg piece of metal from 30 °C to 40 °C. The specific heat capacity of the metal is 720 J / kgK. The heater was turned on for 20 s and it is known that 20 % of the energy supplied is lost to the surrounding. What is the power rating of the heater?

- A 720 W B 864 W C 900 W D 14400 W

- 21 Two liquids, P and Q, of the same masses are placed in a room for cooling. Their cooling curves are shown in the diagram below.

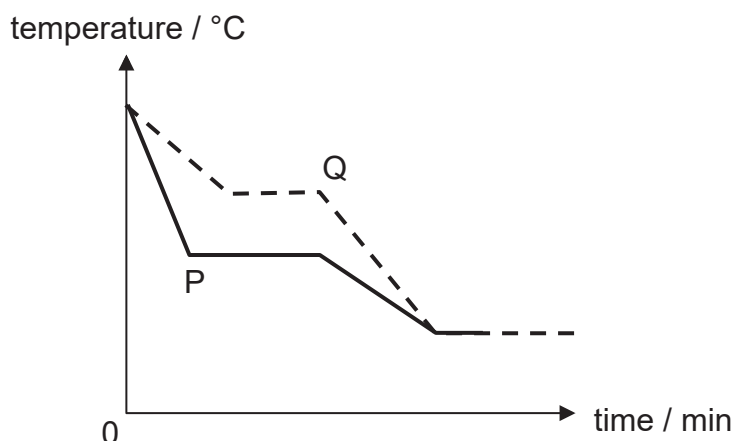

Which of the following statement correctly describes the two liquids, P and Q?

- A Both P and Q has the same specific latent heat of fusion.
 B Both P and Q have the same freezing point.
 C P has a higher specific latent heat of fusion than Q.
 D Q has a lower freezing point than P.

- 22 A plane mirror is inclined at 40° to the table top. An incident ray parallel to the table top strikes the mirror and a reflected ray is formed.

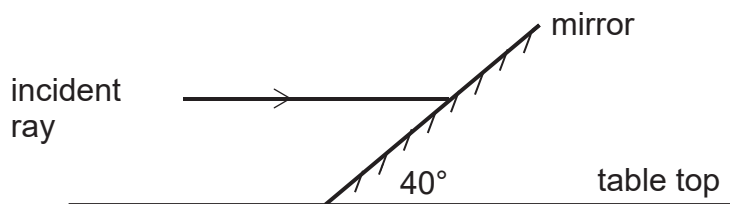

What is the angle of reflection?

- A 20° B 40° C 50° D 100°
- 23 Three rays of light are incident between a glass block and air. The diagram is not drawn to scale.

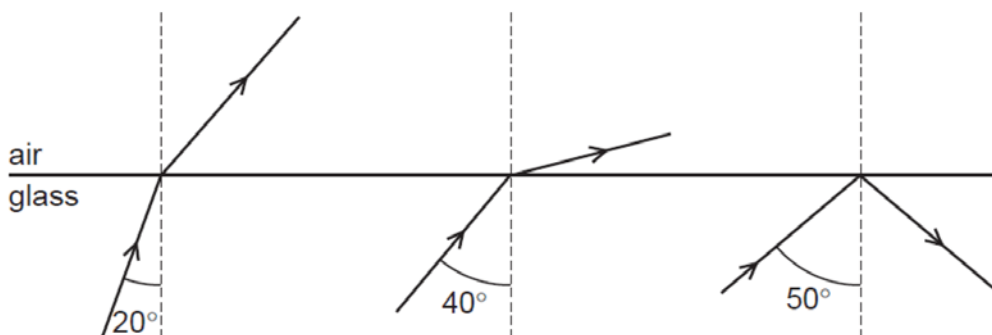

Which of the following is most likely to be the critical angle of the glass?

- A 25° B 35° C 45° D 55°
- 24 An object is placed 35 cm from a converging lens and a real image of the same size as the object is formed. The object is now moved so that it is 20 cm from the lens. Which statement is correct?
- A The new image is bigger and its distance from the lens is less than 35 cm
 B The new image is smaller and its distance from the lens is less than 35 cm.
 C The new image is bigger and its distance from the lens is greater than 35 cm
 D The new image is smaller and its distance from the lens is greater than 35 cm.

- 25 A ball floats on water in a swimming pool.

wave moving to the right

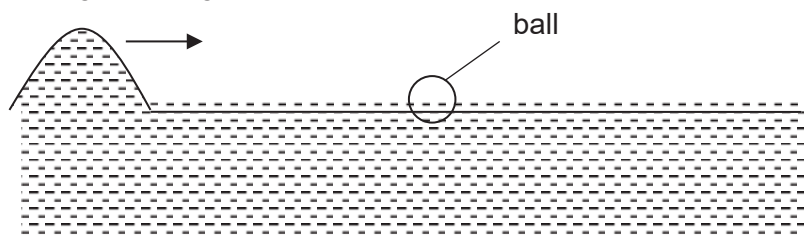

When the wave reaches the ball, how will the ball be displaced?

- A** upwards **B** downwards **C** to the left **D** to the right
- 26 Which of the following is **not** an application of infrared radiation?
- A** remote control
B ear thermometer
C night vision goggles
D sunbeds used for skin tanning
- 27 The diagram shows the relationship between the frequency of electromagnetic radiation and the wavelength of the waves

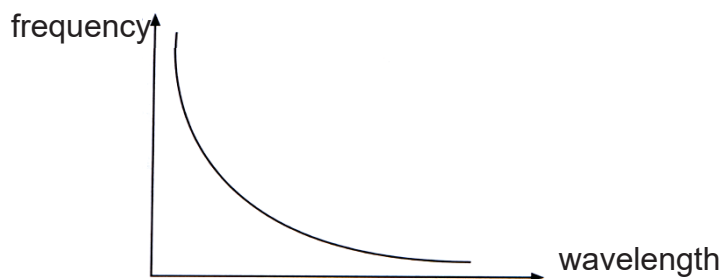

Which of the following relationship can be interpreted from the graph?

- A** The velocity of EM waves is a constant.
B The higher the wavelength, the higher the energy of the wave.
C Frequency is directly proportional to the energy of waves.
D Waves of higher frequency travel faster than waves of lower frequency.

- 28 A starting pistol is fired at the starting line of a race and the echo from the wall is heard 0.5 s later. The speed of sound in air is 330 m/s.
What is the distance between the starting line and the wall?

A 82.5 m **B** 165 m **C** 330 m **D** 660 m

- 29 The electric field patterns produced by three charged spheres are as shown.

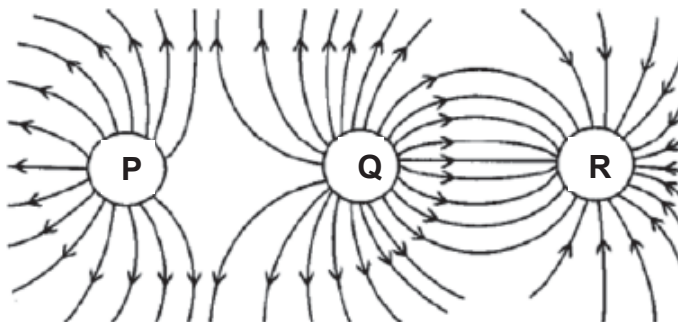

What are the charges on spheres P, Q and R?

- | | P | Q | R |
|----------|----------|----------|----------|
| A | negative | negative | positive |
| B | positive | positive | negative |
| C | positive | negative | negative |
| D | negative | positive | negative |
- 30 A battery drives 100 C of charge around a closed circuit.
The total work done is 750 J. What is the electromotive force of the battery?
- A** 0.13 V **B** 0.75 V **C** 7.5 V **D** 75 kV
- 31 The resistance of a wire is 1.0 Ω .
A second wire is made of the same material but has twice the length and half the diameter. What is the resistance of the second wire?
- A** 0.25 Ω **B** 2.0 Ω **C** 4.0 Ω . **D** 8.0 Ω .

- 32 A 1.8 V power supply is connected to a circuit consisting of three 6.0Ω resistors.

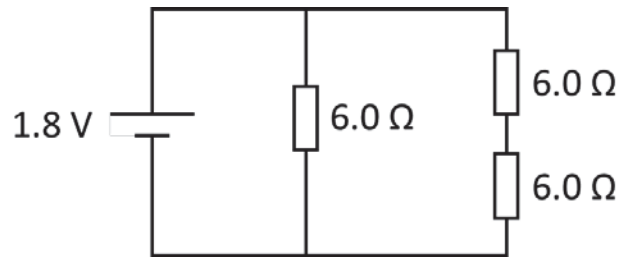

What is the amount of work done by the battery in 1 minute?

- A 18 J B 48.6 J C 108 J D 778 J
- 33 An electrician installed two switches, **S1** and **S2**, to control two lamps, **L1** and **L2**, in the following circuit.

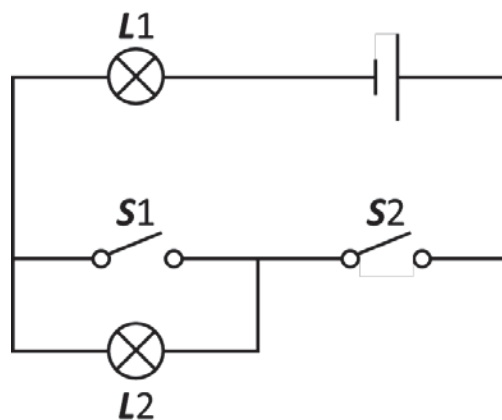

Which of the following configuration will switch on both L1 and L2 at the same time?

- A S1 open, S2 closed
 B S1 open, S2 open
 C S1 closed, S2 closed
 D S1 closed, S2 open

- 34 A magnet is placed on the top of a paper matchbox cover. The set-up is then placed on the tray filled with paper clips. A large number of paper clips are attracted to the based on the matchbox cover.

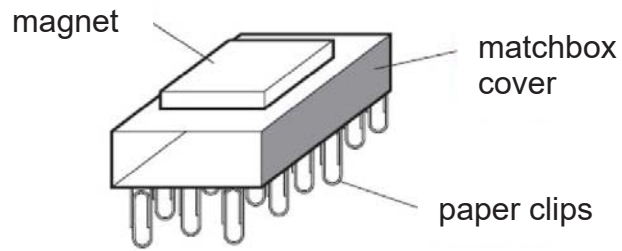

Metal sheets of different materials are thereafter placed inside the matchbox cover. When sheet X is placed inside, the paper clips remained; when sheet Y is placed inside, the paper clips fell off.

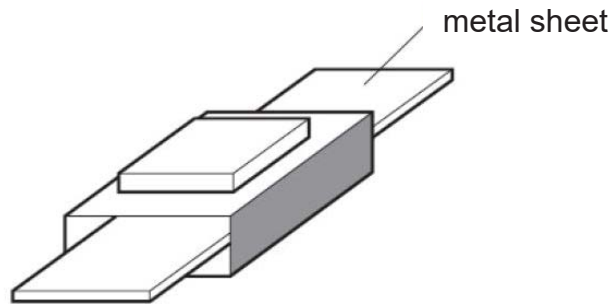

Which of the following metals are the sheets made of?

- | | X | Y |
|----------|----------|----------|
| A | Aluminum | Copper |
| B | Copper | Iron |
| C | Iron | Aluminum |
| D | Iron | Copper |

- 35 In which of the circuits will the filament lamp be less bright if the temperature of the component G decreases?

A

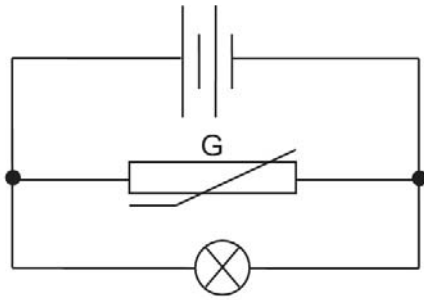

B

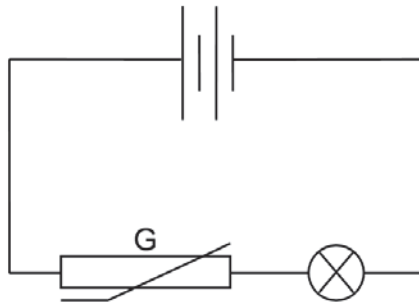

C

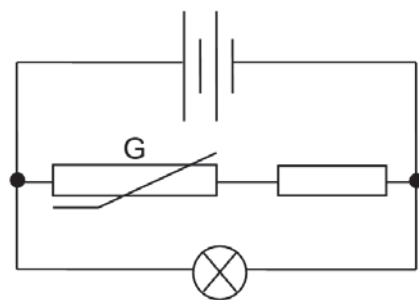

D

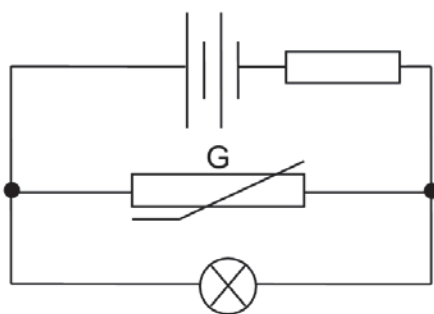

- 36 The diagram shows the cross-section of a cable lying on the ground. There is a direct current in the cable. The Earth's magnetic field is in the direction shown.

In which direction does the electromagnetic force act on the cable?

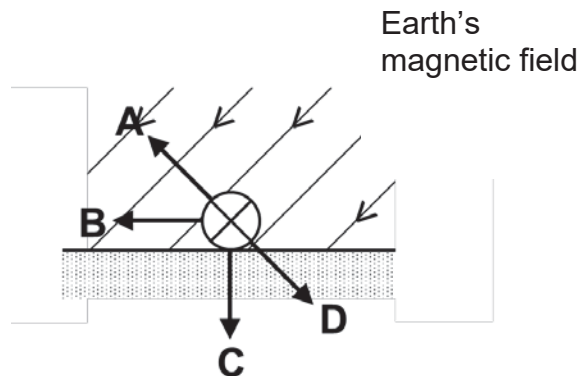

- 37 The diagram below shows a simple d.c. motor. Which of the following labelled parts indicates the commutator?

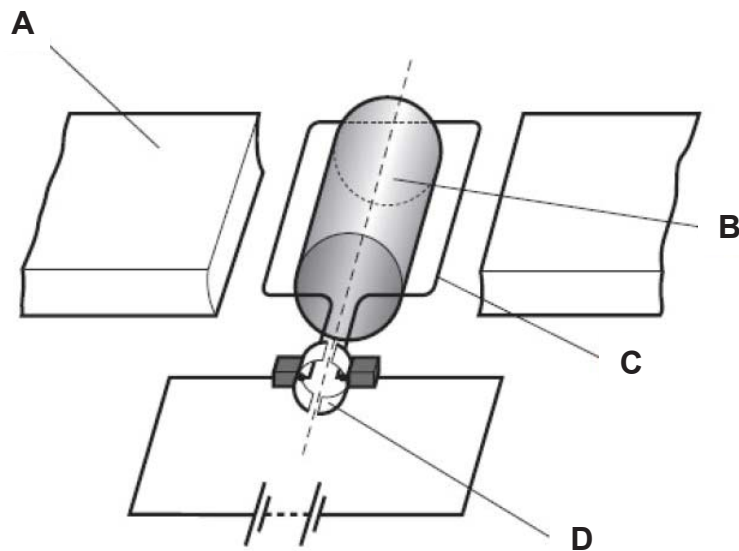

- 38 The diagram below shows a current passing from X to Y.
There is an upward force on the wire.

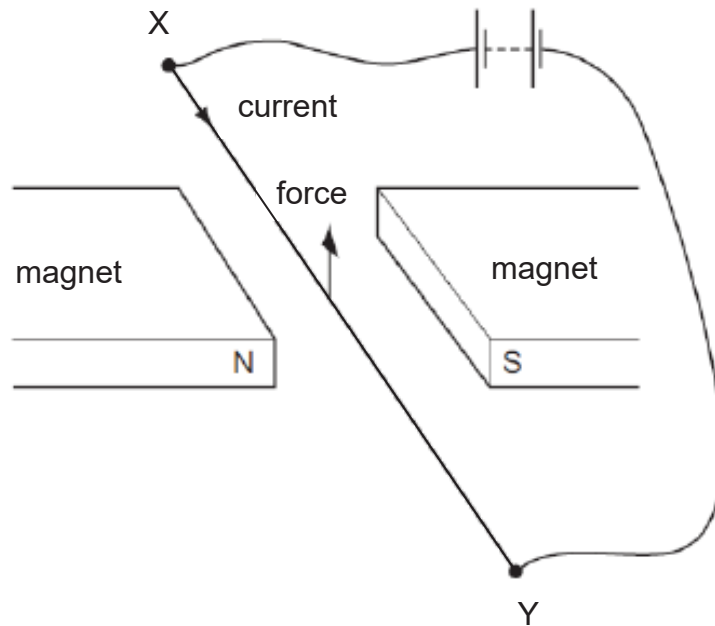

What will be observed if the direction of current reverses?

- A The wire will move upwards.
 B The wire will move downwards.
 C The wire will move towards the left.
 D The wire will move towards the right.
- 39 Which of the following does not affect the magnitude of induced e.m.f in a simple a.c. generator?
- A speed of rotation of coil
 B distance between magnet and rectangular coil
 C number of turns of coil per unit length
 D resistance of rectangular coil

- 40 Two straight electrical conductors are parallel to each other. Each conductor carries a current, one into the plane of the paper, and one out of the plane of the paper.

Which diagram accurately represent the magnetic field around the two wires?

A

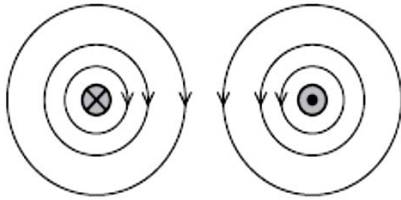

B

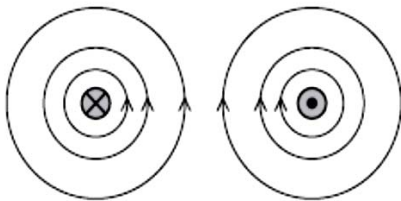

C

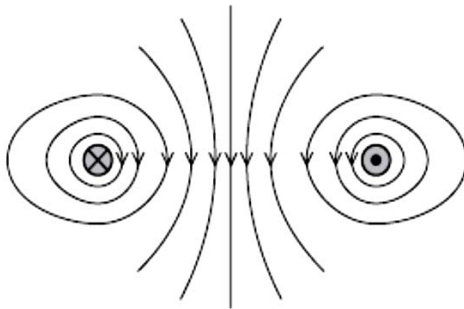

D

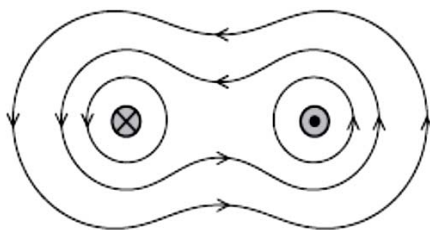

END OF PAPER

NAME :

NO:

CLASS: 4E1

ADMIRALTY SECONDARY SCHOOL



PRELIMINARY EXAMINATION 2019

SUBJECT : Physics
CODE : 6091 / 2
LEVEL/STREAM : Secondary 4 Express
DATE : 30 August 2019
TIME : 0800-0945 hrs
DURATION : 1 hour 45 minutes

Instructions to candidates:

Write your Name, Class and Index Number on all the work you hand in.

Write in dark blue or black pen on both sides of the paper.

You may use a soft pencil for any diagrams, graphs, tables or rough working.

Do not use staples, paper clips, highlighters, glue or correction fluid.

Section A: Short answer questions [50 marks]

Answer all questions. Write your answers in the spaces provided in the question paper.

Section B: Structured questions [30 marks]

Answer all questions. Write your answers in the spaces provided in the question paper.

Question 13 has a choice of either / or.

Candidates are reminded that all quantitative answers should include appropriate units.

The use of an approved scientific calculator is expected, where appropriate.

The number of marks is given in brackets [] at the end of each question or part question.

For Examiner's Use	
Section A	/ 50
Section B	/ 30
Total	/ 80

DO NOT TURN OVER THIS PAPER UNTIL YOU ARE TOLD TO DO SO.

Section A

Answer all questions.

- 1 Fig. 1 shows the velocity time graph of a 150 kg unmanned rocket launched from the surface of planet X. The planet has no atmospheric layer.

It rises vertically upwards with constant acceleration and after some time, a malfunction causes the rocket's engine to cut off suddenly. On its downward journey to the ground, the rocket falls with negligible air resistance.

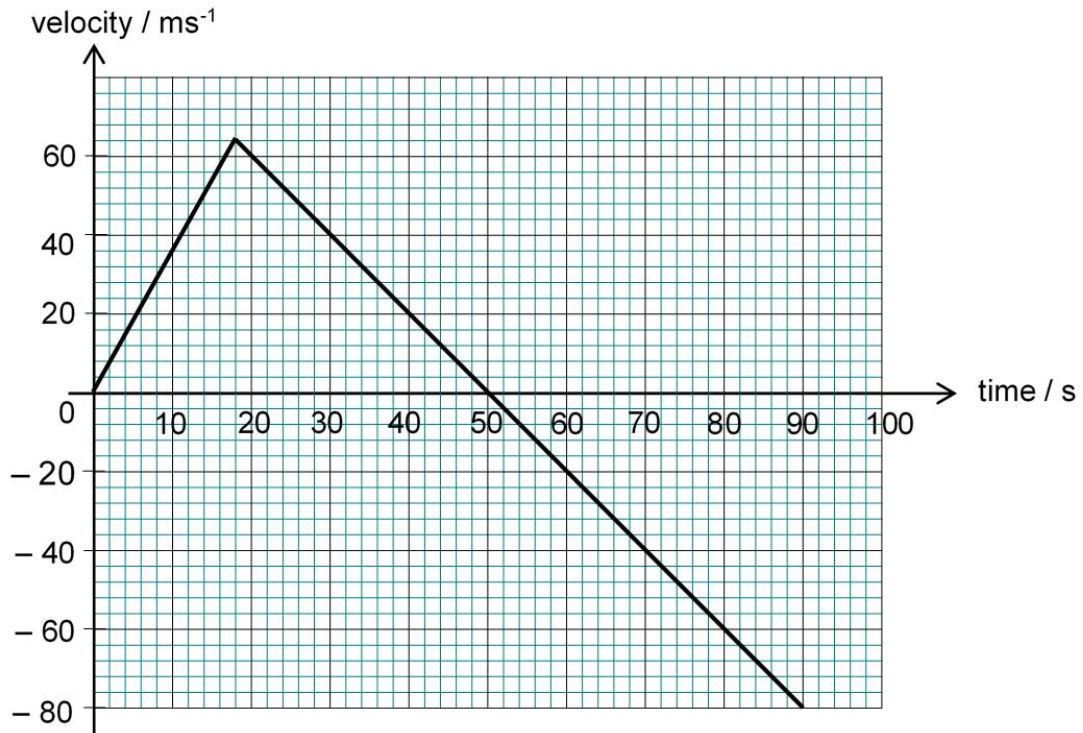
**Fig. 1**

- (a) Using Fig. 1, determine the total distance travelled upwards from the surface of planet X.

upwards distance travelled = [2]

- (b) What is the gravitational field strength of planet X?

gravitational field strength = [2]

- (c) Hence, or otherwise, determine the weight of the unmanned rocket on planet X.

weight = [2]

- 2 Fig. 2 shows the flood prevention system at Marina Barrage. Water is pumped out from Marina reservoir to the sea in instances of heavy rain.

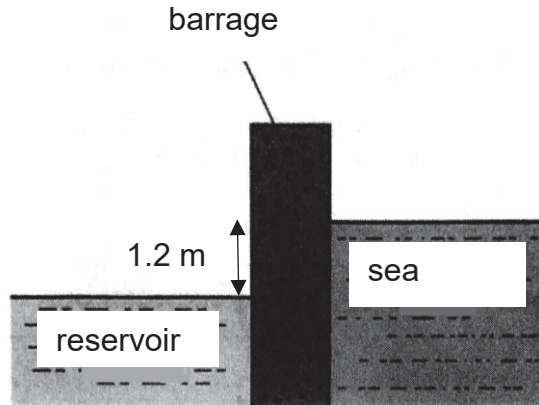

Fig. 2

- (a) Water is released from the reservoir to the sea. The height difference of the reservoir and the sea is 1.2m, and 200 m³ of water is released per second to maintain the reservoir's height. Calculate the power required by the pump if it is 80% efficient. (take density of water as 1000 kg / m³)

power = [3]

- (b) Explain why there is a need for a higher power input than the answer in (a) in real life.

.....

[2]

- 3 A steam engine uses the energy from steam to turn the turbine. Fig. 3 shows a safety valve that is fitted to a steam engine. When the pressure of steam rises above the safety level, the safety valve opens to release steam.

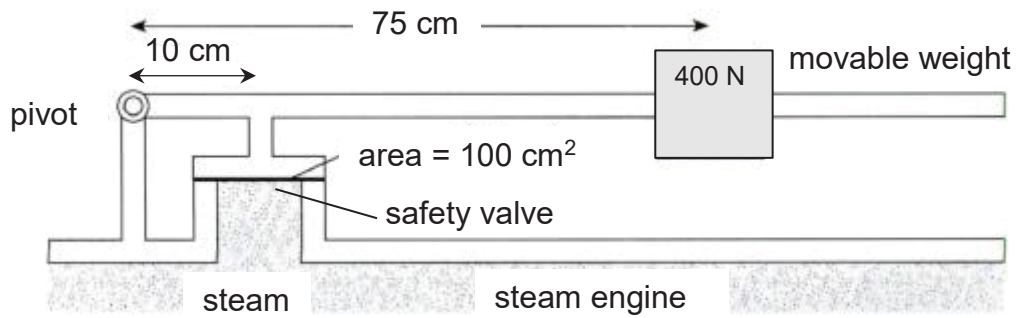

Fig. 3

- (a) Explain, in terms of moments, how the safety valve works.

.....

.....

.....

.....

.....

.....

.....

.....

[3]

- (b) Calculate the minimum force acting on the safety valve before it opens.

force = [2]

- (c) Suggest how the safety valve can be adjusted so that it would release steam at a lower pressure.

.....

.....

.....

.....

[2]

- 4 Two liquids A and B are contained in a U-tube, as shown in Fig. 4. The liquids do not mix.

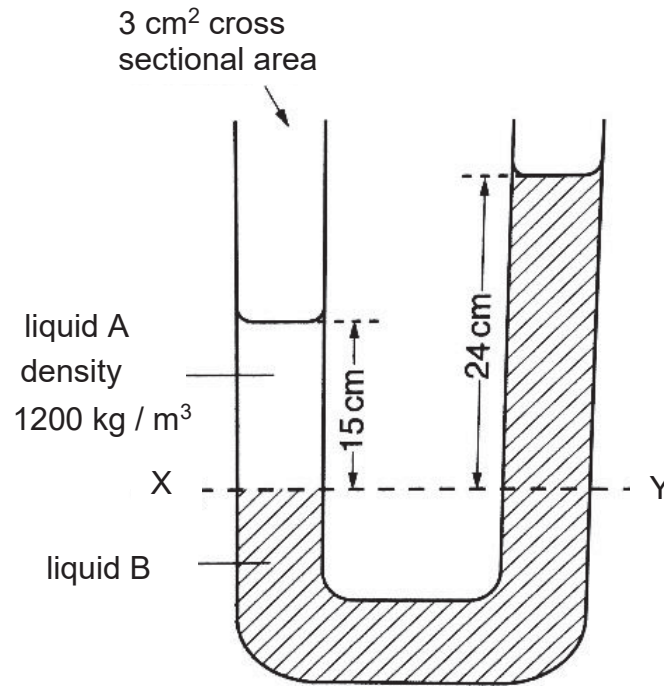

Fig. 4

Point X is at the junction between liquids A and B.

Point Y is at the same horizontal level in liquids B. The surface of liquid A is 15 cm above point X. The surface of liquid B is 24 cm above point Y. The density of liquid A is 1200 kg / m^3 . Assume gravitational field strength is 10 N/kg .

- (a) Calculate the pressure at point X due to liquid A.

pressure = [2]

- (b) Hence, determine the density of liquid B.

density = [2]

5 Fig. 5 shows a side view and a plane view of a container used to serve hot drinks.



Layer of corrugated cardboard stuck to a layer of smooth cardboard, with gaps between

Fig. 5

(a) Explain how the design allows the person to safely hold the cup with hot drinks.

.....
.....
.....
.....

[2]

(b) Two cups of coffee, one in a corrugated cardboard cup, another in a ceramic mug, contains coffee of the same temperature. After 5 minutes, predict which container will contain coffee with the higher temperature. Explain your answer.

.....
.....
.....
.....

[2]

- 6 Fig. 6 shows a pool of water of depth 1.00 m. Rays of light travel in water from an underwater lamp.

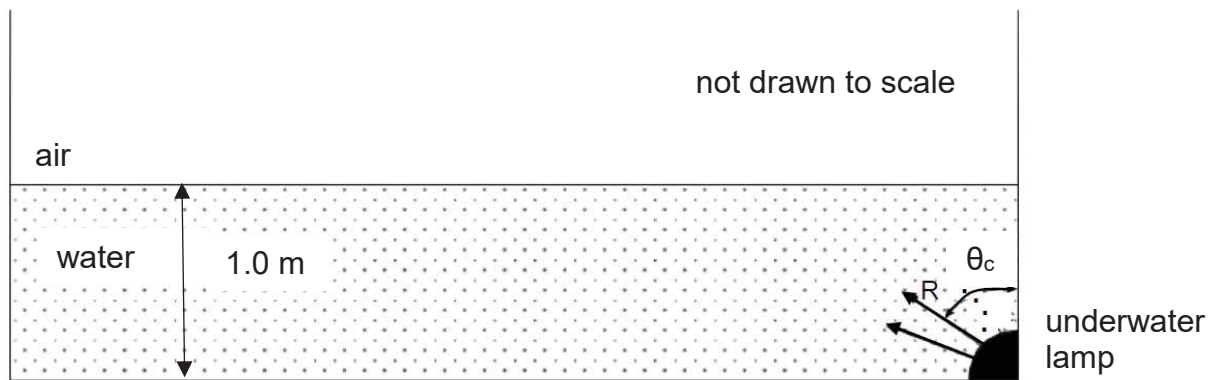

Fig. 6

Given that the refractive index of water in the pool is 1.33.

- (a) Determine the speed of light in water.

speed of light in water = [2]

- (b) Calculate critical angle, θ_c and complete ray R on Fig. 6

θ_c = [3]

- 7 Fig. 7 shows an application of electrostatic charges known as electrostatic coating. A nozzle produces paint droplets, all of which are given a positive charge. The metal panel is given a negative charge.

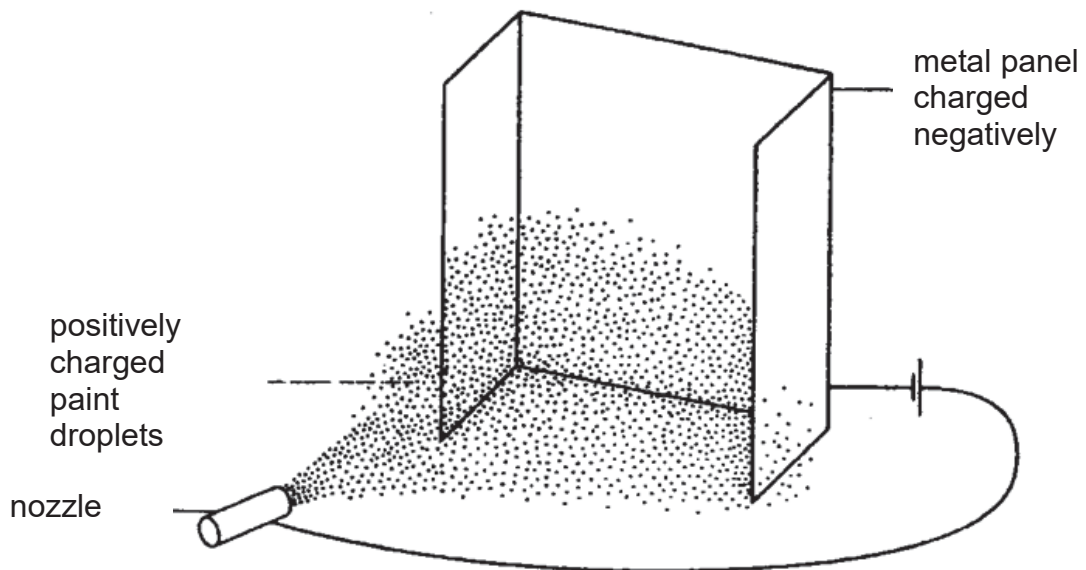

Fig. 7

- (a) Explain how this method reduces the amount of paint needed to paint a large surface.

.....

.....

.....

.....

[2]

- (b) A student suggests that the metal panel can be of neutral charge as the positively charged paint droplets would be attracted to neutral objects too. Explain why his suggestion is not feasible in this context.

.....

.....

.....

.....

[2]

- 8 Fig. 8 shows the circuit of an electric iron with a metal casing connected to the live (L), neutral (N) and earth (E) terminals.

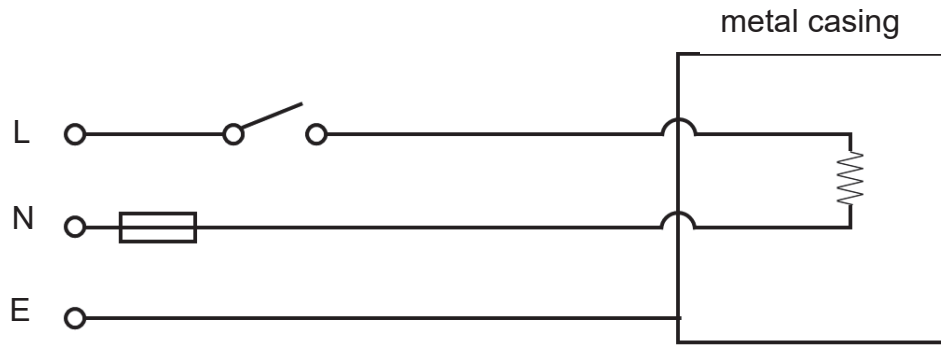

Fig. 8

- (a) Explain how the earth wire protects the user from an electrical shock.

.....

.....

.....

.....

[2]

- (b) There is a hazard in the circuitry in Fig. 8. Identify the hazard and explain why it is unsafe.

.....

.....

.....

.....

[2]

- (c) The power rating of the iron is 220 V, 2400 W.
- (i) The iron is used for 10 minutes daily for 30 days in a month. How much does it cost if each unit of electricity is \$0.20?

cost = [2]

- (ii) Determine the power of the iron when it is plugged into a 110 V power socket.

cost = [2]

9 Fig. 9 shows the representation of a step-up transformer.

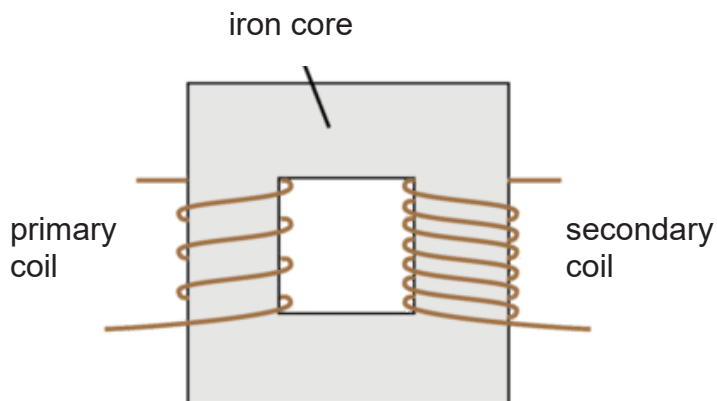

Fig. 9

(a) State one way to increase the secondary voltage of a step-up transformer.

.....

[1]

(i) Explain the function of the iron core and why it cannot be replaced by steel.

.....

[2]

(b) A step up transformer has an input voltage of 240 V, 13 A, with a turns ratio of 200.

(i) Calculate the output current of the transformer.

Output current = [2]

(ii) Explain why step-up transformers are usually used before electricity is transmitted by transmission cables.

.....

[2]

Section B

Answer all the questions in this section.

Question 12 is in the form Either / Or.

- 10** Fig. 10.1 shows some information from the manufacturer of a car.
The kerb mass refers to the mass of the car without passengers and cargo.
The gross mass refers to the mass of the car with passengers and/or cargo.

kerb mass	850 kg
gross mass (with a 70 kg driver)	920 kg
gross mass (with a 70 kg driver and a 70 kg passenger)	990 kg

	with one driver only	with one driver and passenger
maximum acceleration	3.50 m/s ²	3.25 m/s ²
maximum speed	50.0 m/s	50.0 m/s

Fig. 10.1

- (a)** When the mass of the people in the car doubles from 70 kg to 140 kg, there is only a slight decrease in the maximum acceleration.

Explain why the acceleration did not decrease by half when the mass of people doubled.

.....
.....

[1]

- (b)** Calculate the shortest time for the car, with a driver and a passenger inside, to achieve the maximum speed from rest.

time = [2]

- (c)** Ignoring air resistance, calculate the maximum forward thrust of the car engine.

maximum thrust = [2]

- (d) The driver takes the car for a test drive without any passenger. While travelling at the maximum speed, the driver sees a police car ahead and applies the brake after 2.0 s. The car decelerates uniformly and comes to rest a short distance away from the police car.

Fig. 10.2 shows how the speed of the car varies with time after the driver sees the police car.

time / s	speed / m/s
0.0	50.0
2.0	50.0
4.0	40.0
6.0	30.0
8.0	20.0
10.0	10.0
12.0	0.0

Fig. 10.2

- (i) State what it means by “decelerates uniformly”.

.....

[1]

- (ii) Calculate the distance travelled by the car during the deceleration.

distance = [2]

- (iii) Describe how the distance between the car and the police car changes before and after the driver applies the brake.

.....

[2]

11 (a) Water is in liquid state at room temperature of 25 °C.

(i) Using kinetic theory of matter, describe the change that occurs when water evaporates.

.....

[2]

(ii) State one difference between the molecules in steam and molecules in water.

.....

[1]

(b) Fig. 11.1 shows liquid nitrogen, below its boiling point, stored in a vacuum flask. The boiling point of nitrogen is -196 °C.

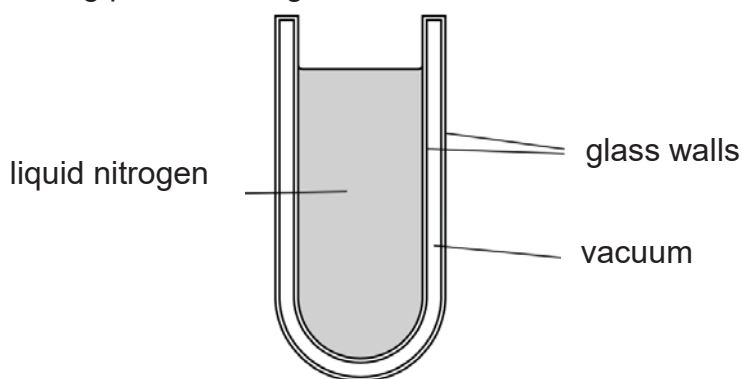

Fig. 11.1

The flask has 2 glass walls with a vacuum between them. State and explain the purpose of having a vacuum between the two layers of glass walls

.....

[3]

(c) The liquid nitrogen reaches its boiling point of $-196\text{ }^{\circ}\text{C}$. A small piece of metal at $20\text{ }^{\circ}\text{C}$ is lowered slowly into the liquid nitrogen. Bubbles form within the liquid nitrogen as it boils. The small piece of metal has a mass of 50 g. When it is lowered into the liquid nitrogen, the metal cools to $-196\text{ }^{\circ}\text{C}$. The specific heat capacity of the metal is $0.39\text{ J}/(\text{gK})$. The specific latent heat of vaporisation of nitrogen is 200 J/g .

(i) Calculate the thermal energy lost by the metal as it cools.

thermal energy lost = [2]

(ii) Hence, determine the mass of nitrogen that boils away.

mass of nitrogen = [2]

12 Either

A circuit is set up as shown in Fig. 12.1. The resistance of the LDR varies from $800\ \Omega$ to $2400\ \Omega$ under different brightness.

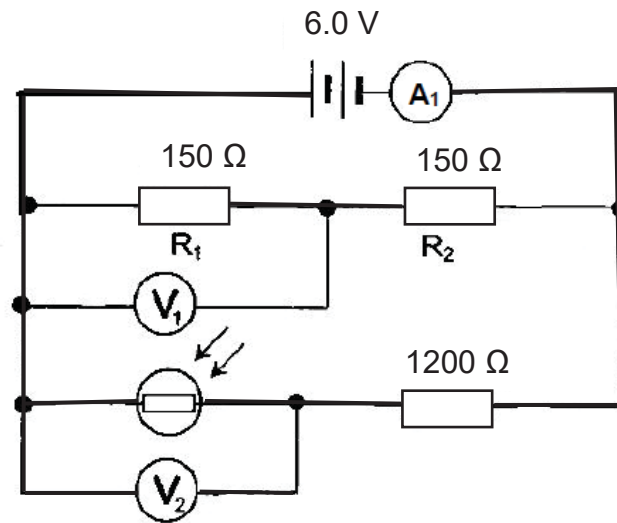

Fig. 12.1

- (a) State the voltmeter reading on V_1 .

$V_1 = \dots\dots\dots$ [1]

- (b) Calculate the reading shown on the ammeter A_1 when the LDR's resistance is $800\ \Omega$.

reading on $A_1 = \dots\dots\dots$ [4]

- (c) In Fig. 12.2, sketch the graph to show how the resistance of the LDR varies with light intensity



[1]

Fig. 12.2

- (d) (i) Calculate the voltmeter reading V_2 when the light intensity is low.

$V_2 = \dots\dots\dots$

[2]

- (ii) An ammeter A_2 is connected across X and Y as shown by Fig. 12.3. State the direction of current flow and explain your answer.

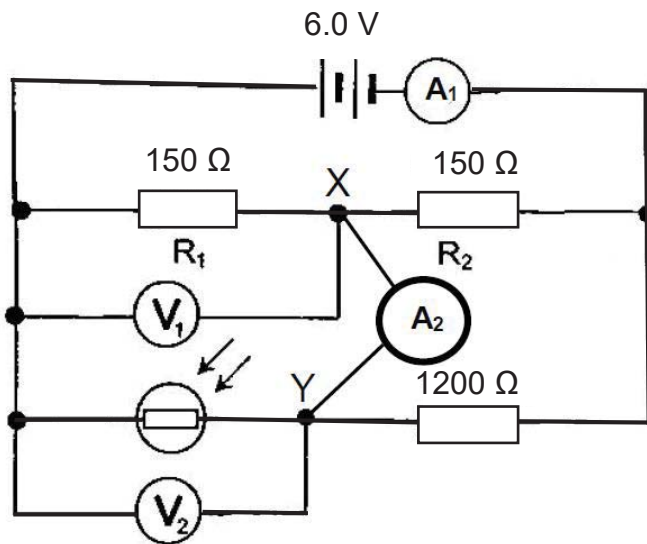

Fig. 12.3

.....

.....

.....

.....

[2]

12 Or

Fig. 12.4 shows how the vibrations of a modern electric guitar string are picked up by a small coil of wire wound around a cylindrical magnet. The string, which is made of steel, causes an electrical signal to be generated and detected.

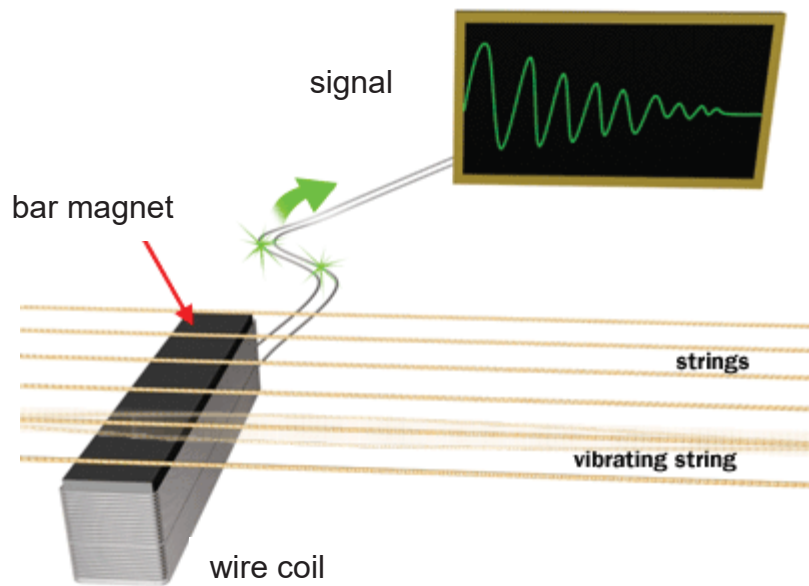

Fig. 12.4

(a) State Faraday's Law of Electromagnetic Induction.

.....

.....

.....

[1]

(b) Using Faraday's Law, explain how the electrical signal is generated.

.....

.....

.....

.....

.....

.....

.....

[3]

- (c) State and explain if any signal would be generated if the string of the electrical guitar is changed to nylon.

.....

.....

.....

..... [2]

- (d) Fig. 12.5 shows the display on a screen when the signal of a note is being detected. The horizontal scale indicating the time base is set to 2.0 ms/cm.

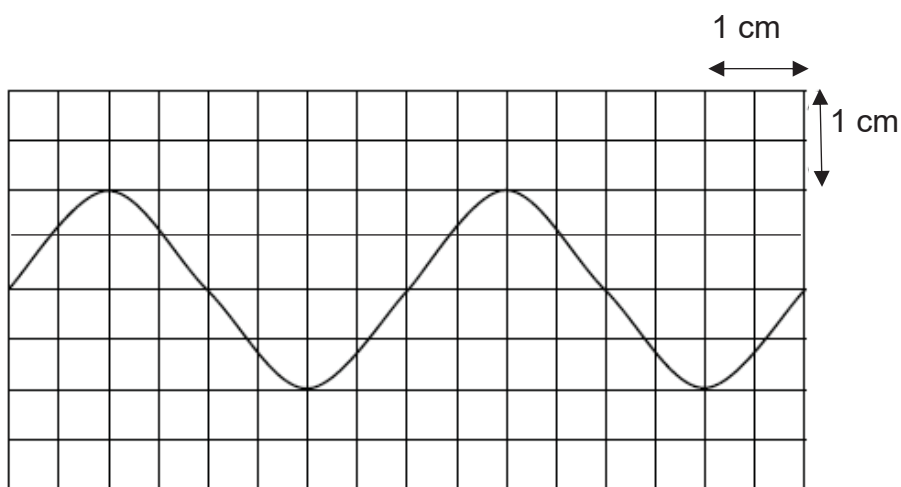

Fig. 12.5

- (i) Calculate the frequency of the note being played.

frequency = [2]

- (ii) State what happens to the frequency and amplitude of the sound wave when it is played through a loudspeaker.

.....

.....

.....

..... [2]

