

Visit

FREETESTPAPER.com

for more papers



Website: [freetestpaper.com](http://www.freetestpaper.com)



[Facebook.com/freetestpaper](https://www.facebook.com/freetestpaper)



[Twitter.com/freetestpaper](https://www.twitter.com/freetestpaper)

Name: _____ ()

Class: _____

PRELIMINARY EXAMINATION
GENERAL CERTIFICATE OF EDUCATION ORDINARY LEVEL

PHYSICS

6091/01

Paper 1 Multiple Choice

Tuesday 3 September 2019

1 hour

READ THESE INSTRUCTIONS FIRST

Write in soft pencil.

Do not use staples, paper clips, highlighters, glue or correction fluid.

Write your name, index number and class on the Answer Sheet in the spaces provided.

There are **forty** questions on this paper. Answer **all** questions. For each question there are four possible answers **A, B, C** and **D**.

Choose the one you consider correct and record your choice in soft pencil on the separate Answer Sheet.

Read instructions on the Answer Sheet very carefully.

Each correct answer will score one mark. A mark will not be deducted for a wrong answer. Any rough working should be done on this booklet.

The use of an approved scientific calculator is expected, where appropriate.

This document consists of **19** printed pages and **1** blank page.



圣尼各拉女校

CHIJ ST. NICHOLAS GIRLS' SCHOOL

Girls of Grace • Women of Strength • Leaders with Heart

[Turn over

- 1 A manufacturer measures the three dimensions of a floor tile using three different instruments. The approximate dimensions of the tile are shown.

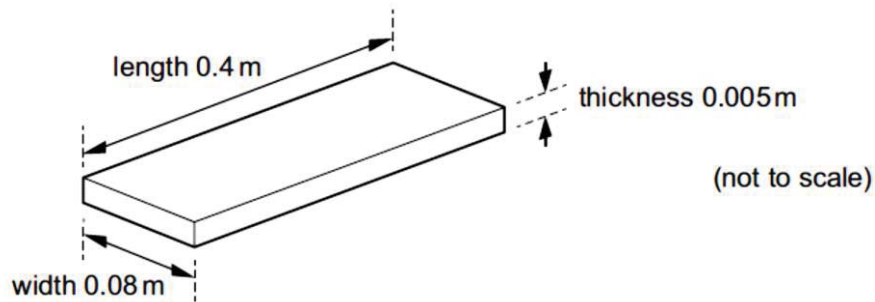

Which instruments are used to measure accurately each of these dimensions?

	length	width	thickness
A	calipers	micrometer	metre rule
B	metre rule	micrometer	calipers
C	metre rule	calipers	micrometer
D	micrometer	metre rule	calipers

- 2 Two forces, X and Y, act on an object and produce a resultant force. The diagram represents the sizes and directions of forces X and Y.

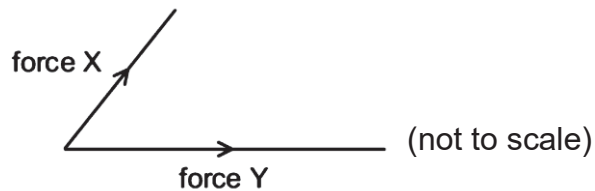

Force Z balances the resultant force due to X and Y and keeps the object stationary.

Which arrow represents force Z?

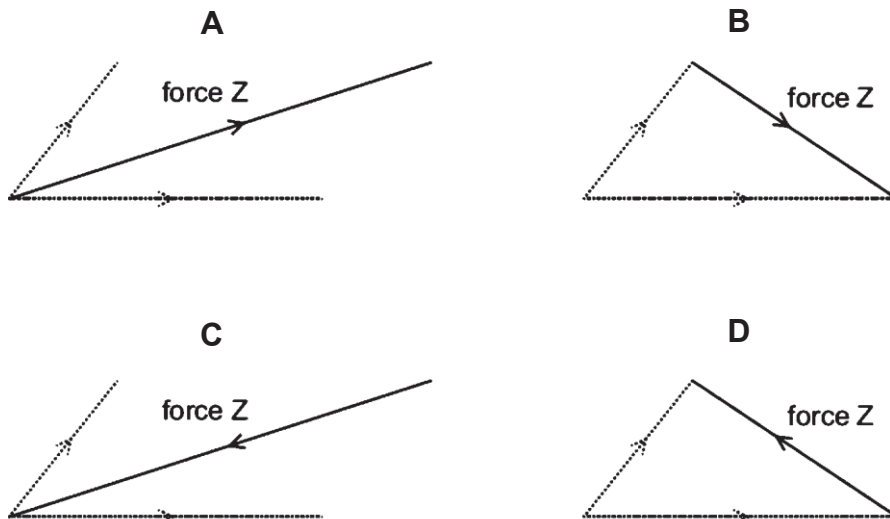

- 3 A student used a micrometer screw gauge to measure the thickness of a metal sheet.

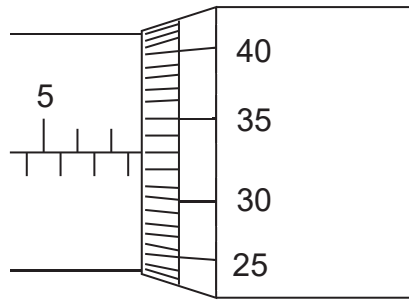

What is the thickness of the metal sheet?

- A 5.83 mm B 7.33 mm C 7.83 mm D 10.33 mm
- 4 Two blocks are joined together as shown below.

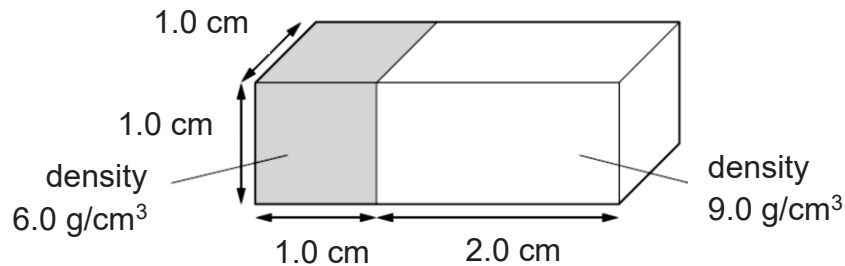

One block has a density of 6.0 g/cm^3 and the other has a density of 9.0 g/cm^3 . What is the overall density of the two blocks joined together?

- A 7.0 g/cm^3
 B 7.5 g/cm^3
 C 8.0 g/cm^3
 D 15 g/cm^3
- 5 A trolley with a ticker-tape attached to it, moves down a runway. The ticker-tape timer operates at a frequency of 50 Hz on the tape. The diagram below shows two sections from tape P and Q, separated by 25 spaces.

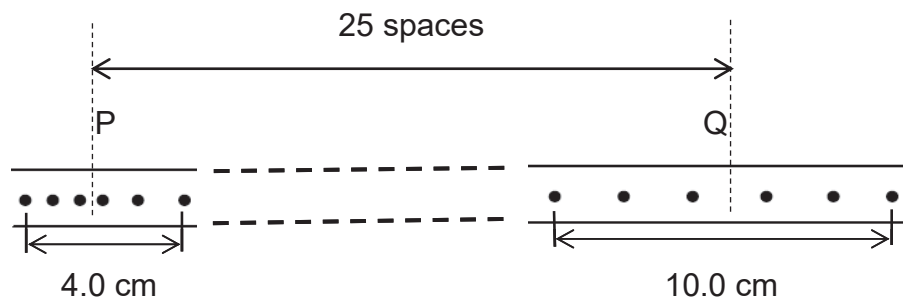

Calculate the average acceleration of the trolley.

- A 0.4 m/s^2
 B 0.6 m/s^2
 C 0.8 m/s^2
 D 1.2 m/s^2

- 6 The distance travelled by a car is increasing uniformly as it is driven along a straight road up a hill.

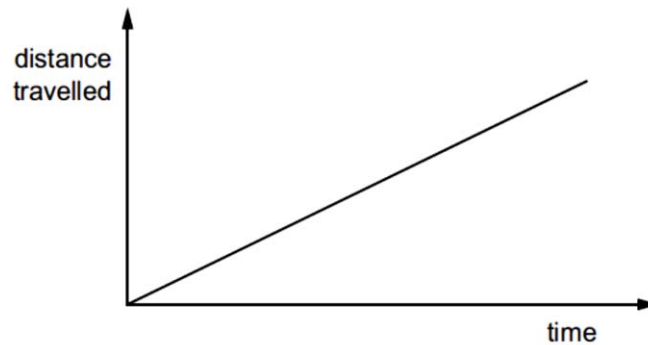

Which quantity of the car is constant but not zero?

- A acceleration
 B displacement
 C gravitational potential energy
 D kinetic energy
- 7 Which moving body has a resultant force acting on it?
- A a parachutist descending vertically at terminal velocity
 B a diver rising vertically through water at constant speed
 C an aircraft circling an airport at constant speed
 D a train going up a straight incline at constant speed
- 8 An engine pulls a truck at constant speed on a level track.

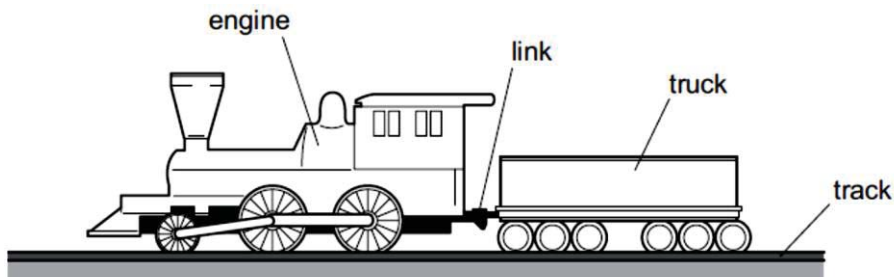

The link between the engine and the truck breaks. The driving force on the engine remains constant.

What effect does this have on the engine and the truck?

	engine	truck
A	speed stays constant	slows down
B	speeds up	slows down
C	speed stays constant	stops immediately
D	speeds up	stops immediately

- 9 A free-fall skydiver jumps from a plane. As he falls, there is a force acting upwards and a force acting downwards on his body. These produce a resultant force.

Before he reaches terminal velocity, how do the sizes of the forces change?

	downward force	upward force	resultant force
A	decreases	decreases	stays the same
B	increases	stays the same	decreases
C	stays the same	increases	decreases
D	stays the same	increases	increases

- 10 The diagram shows an axle fixed to a wheel. The axle of radius 5.0 cm is pulled by a force F so that the wheel of radius 30.0 cm turns clockwise. The wheel moves forward at constant speed and experience a frictional force of 1000 N between the wheel and the floor. The mass of the wheel and axle is 200 kg.

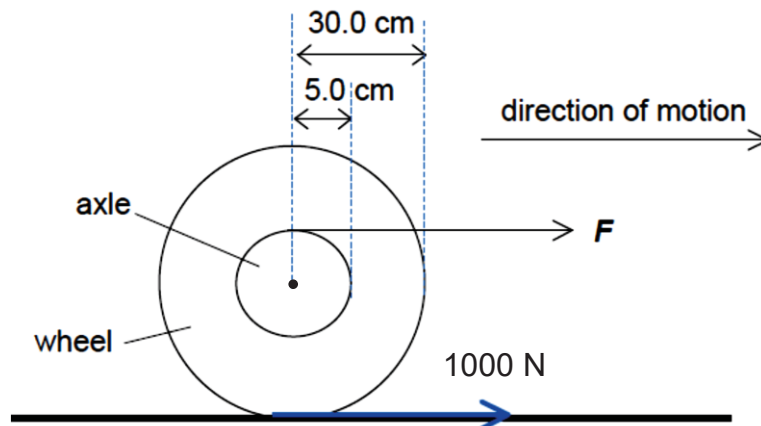

What is the force F acting on the axle?

- A 167 N
- B 1 000 N
- C 6 000 N
- D 8 000 N

- 11 A force F acts on an L-shaped object pivoted at point P. Which of the following will produce the largest turning moment about pivot P?

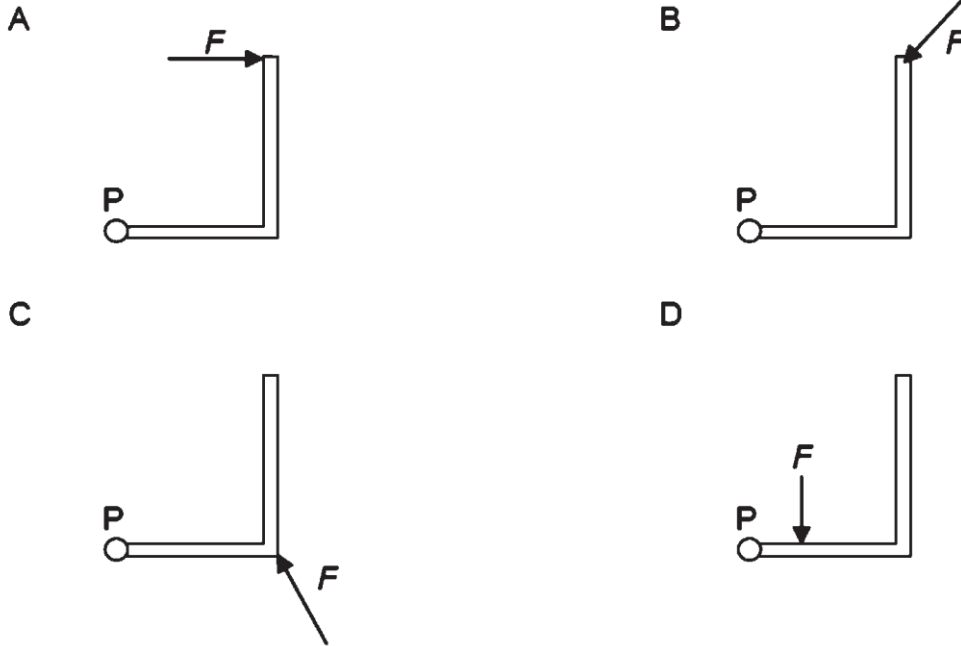

- 12 A car of mass 1500 kg has a speed of 20 m/s. It accelerates until its speed is 25 m/s. What is the increase in the kinetic energy of the car?

- A 19 kJ
 B 38 kJ
 C 170 kJ
 D 340 kJ

- 13 A man exerts a horizontal force of 600 N on a box as shown in the diagram. A frictional force of 200 N acts in the opposite direction. The box moves 3.0 m in 5.0 s.

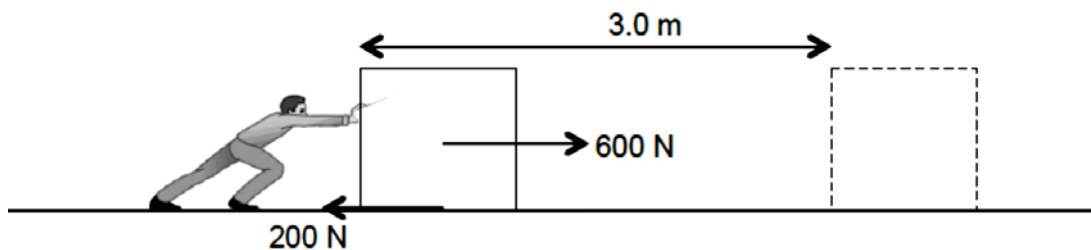

What is the useful power in pushing the box forward?

- A 120 W
 B 240 W
 C 360 W
 D 480 W

- 14 The energy supplied to an electric motor is E , and, in the same time, the energy wasted by the motor is W .

What is the efficiency of the motor?

- A $\frac{E}{W}$
- B $\frac{W}{E}$
- C $\frac{(E-W)}{W}$
- D $\frac{(E-W)}{E}$

- 15 Which graph shows the total external pressure acting on a submarine at different depths below the surface of the sea? Assume the change in density of sea water is negligible.

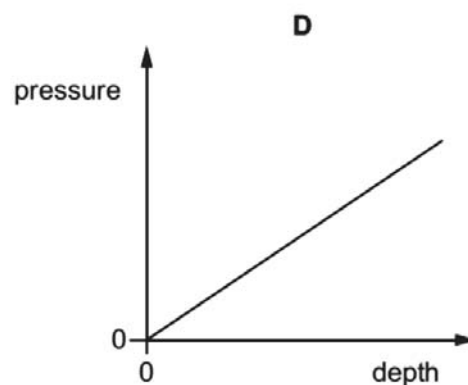
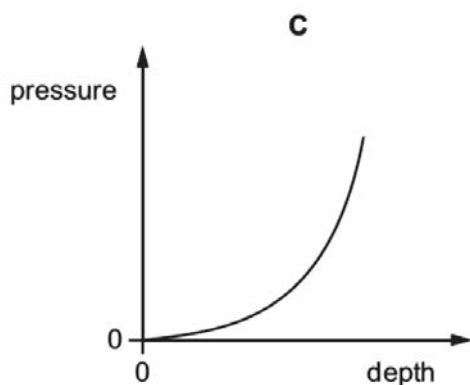
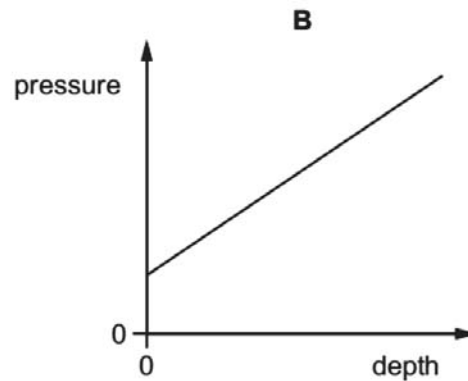
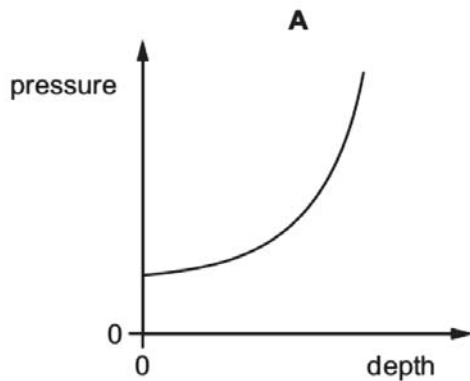

- 16 The diagram shows a simple hydraulic jack. A downward force of 20 N is exerted on piston X, causing it to move down by 30 cm.

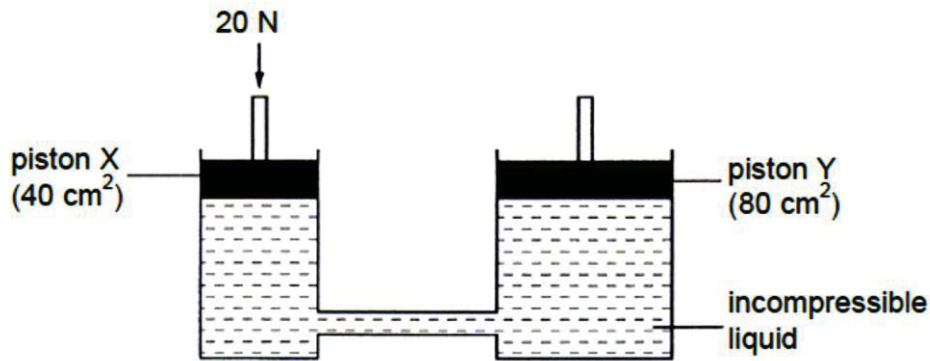

What is the upward force on piston Y and the distance moved by piston Y raised?

	upward force on piston Y	distance moved by piston Y
A	40 N	15 cm
B	40 N	20 cm
C	80 N	10 cm
D	80 N	15 cm

- 17 The diagram shows a U-tube manometer containing three liquids: mercury, liquid X and liquid Y. Neither liquid X or liquid Y mixes with mercury.

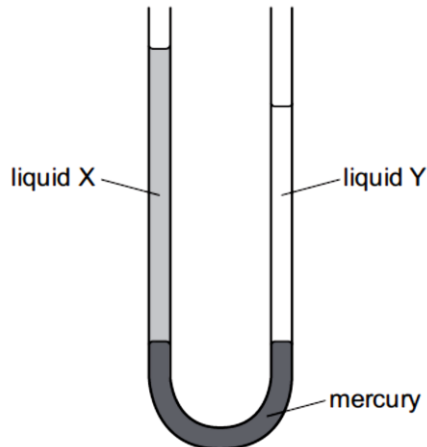

Which correctly describes the densities of X and Y, and the pressures they exert on the mercury?

	pressure exerted on the mercury	densities of X and Y
A	pressure of X is greater than Y	density of X is greater than Y
B	pressure of Y is greater than X	density of Y is greater than X
C	pressure of X and of Y are the same	density of X is greater than Y
D	pressure of X and of Y are the same	density of Y is greater than X

- 18 Air is trapped in a cylinder by a piston. The pressure of the air is p and the length of the air column is 20 cm. The piston is moved outwards until the length of the air column has increased by 40 cm. The temperature of the air remains constant.

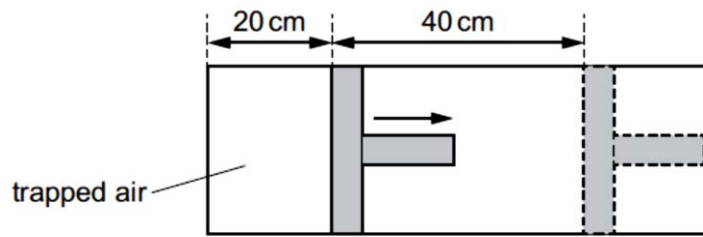

What is the new air pressure?

- A $p/2$
 B $p/3$
 C $2p$
 D $3p$
- 19 Some gas is trapped in a closed container. The gas is cooled and the volume of the container is kept constant.

What happens to the gas molecules?

- A They collide with the walls more often.
 B They contract.
 C They get closer together.
 D They move more slowly.
- 20 A column of dry air is trapped by a pellet of mercury in a capillary tube. The capillary tube is held in different positions as shown in the diagrams.

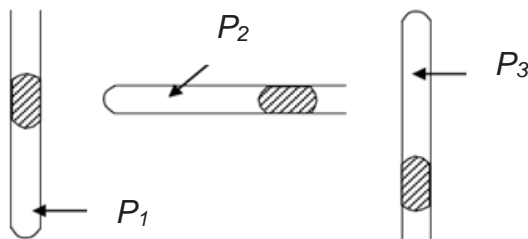

Compare the air pressures P_1 , P_2 and P_3 .

- A $P_1 > P_2 > P_3$
 B $P_3 > P_2 > P_1$
 C $P_1 > P_3 > P_2$
 D $P_1 = P_2 = P_3$

- 21 A 125 g piece of solid lead at room temperature is heated. It completely melted after 22 s. The graph shows how its temperature varies with time.

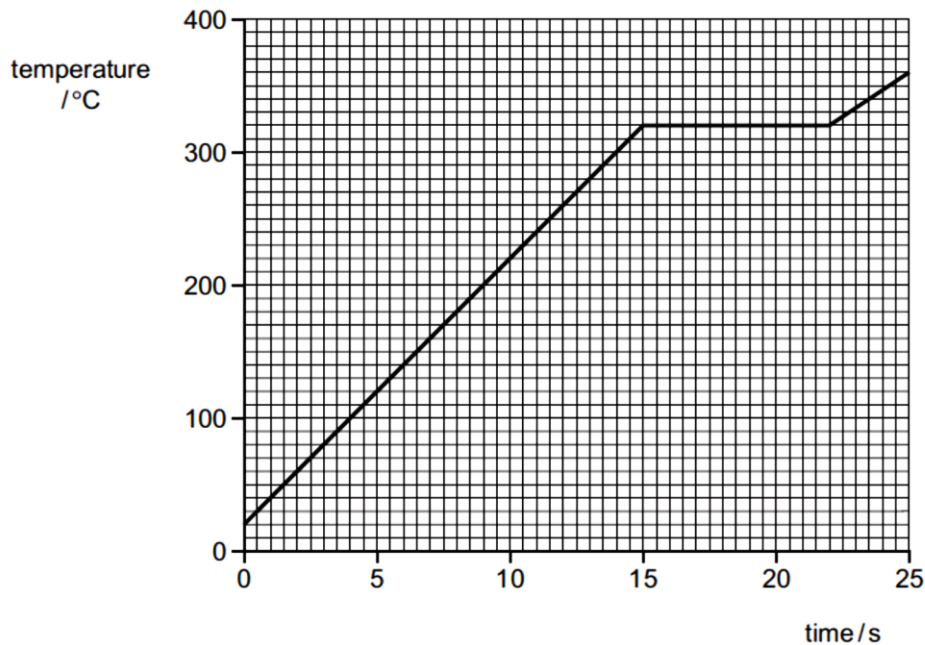

The power of the heater is 400 W. What is the specific latent heat of fusion of lead, in J/kg?

- A $\frac{7.0 \times 400}{0.125 \times 300}$
- B $\frac{22 \times 400}{0.125 \times 300}$
- C $\frac{7.0 \times 400}{0.125}$
- D $\frac{22 \times 400}{0.125}$
- 22 A slice of bread is placed under a red-hot electric grill to make toast.

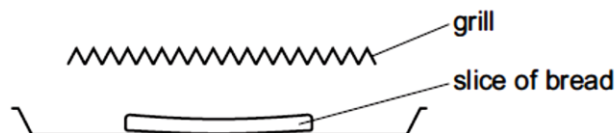

How does heat reach the bread?

- A conduction and convection
- B conduction and radiation
- C convection and radiation
- D radiation only

- 23 A thermometer is used to measure a temperature of $80\text{ }^{\circ}\text{C}$.

Which thermometer is the most sensitive?

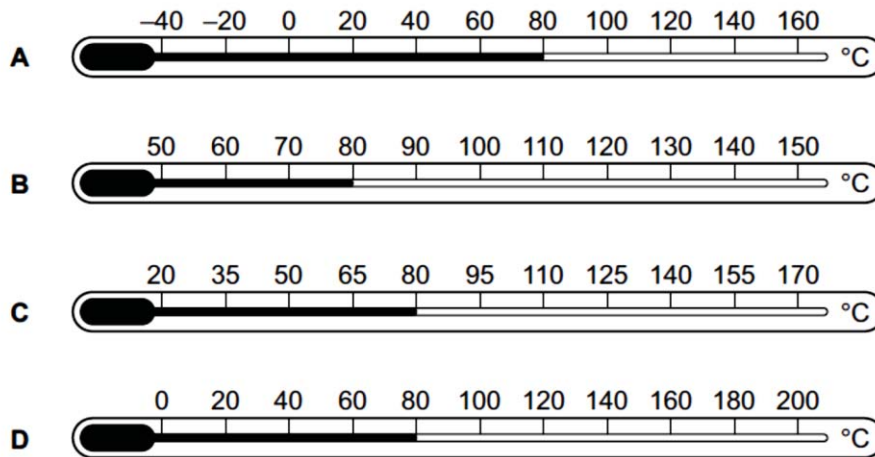

- 24 The graph shows a water wave with frequency 10 Hz traveling from left to right. The displacement of particle P on the wave at this instant is zero.

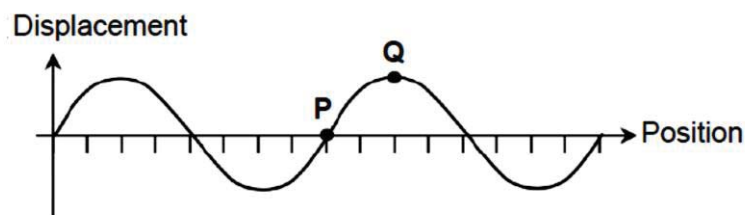

How long later would particle Q be at zero displacement?

- A 0.025 s
 B 0.050 s
 C 0.10 s
 D 2.5 s
- 25 Which device uses ultrasound?

- A an optical fibre
 B a pre-natal scanner
 C a steriliser
 D a sunbed

26 Which statement about microwaves is correct?

- A Microwaves are longitudinal waves.
- B In vacuum, the speed of microwaves is equal to speed of visible light.
- C The frequencies of microwaves are greater than the frequencies of visible light
- D The wavelengths of microwaves are smaller than the wavelengths of infra-red.

27 A solid plastic cylinder is immersed in a liquid of refractive index 1.4. Light travelling in the plastic cylinder strikes the inside surface at an angle of incidence of 70° . The light undergoes total internal reflection.

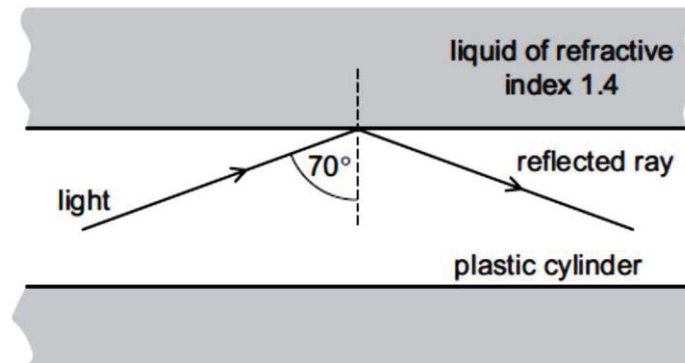

What are the values of the critical angle in the plastic and the refractive index of the plastic?

	critical angle in the plastic	refractive index of the plastic
A	greater than 70°	greater than 1.4
B	greater than 70°	less than 1.4
C	less than 70°	greater than 1.4
D	less than 70°	less than 1.4

- 28 The ray diagrams 1 and 2 show two ways in which a thin converging lens produces an image that is larger than the object.

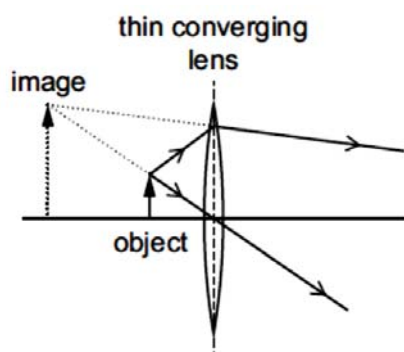

diagram 1

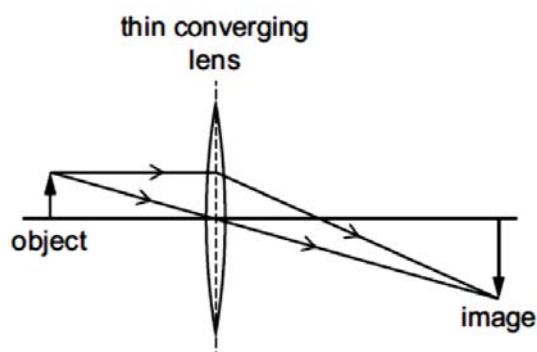
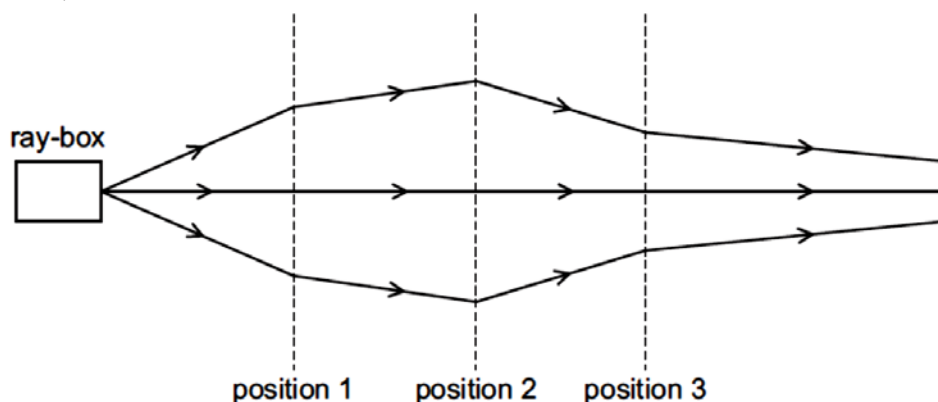

diagram 2

Which devices use lenses in the ways as shown in diagrams 1 and 2?

	diagram 1	diagram 2
A	camera	magnifying glass
B	magnifying glass	projector
C	photographic enlarger	camera
D	photographic enlarger	projector

- 29 The diagram shows rays of light from a ray-box passing through three lenses placed at positions 1, 2 and 3.



What type of lens is used at each position?

	position 1	position 2	position 3
A	converging	converging	converging
B	converging	converging	diverging
C	diverging	converging	diverging
D	diverging	diverging	converging

- 30** A positively charged metal sphere is placed midway between two previously uncharged metal rods, one of which is connected to earth.

Which diagram shows the charges on the rods?

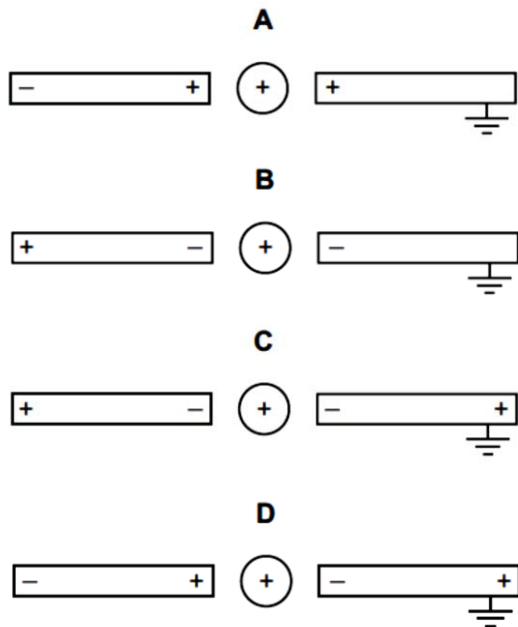

- 31** The diagram shows two charged parallel plates. Four negatively charged identical particles, *P*, *Q*, *R* and *S* are placed in between the plates.

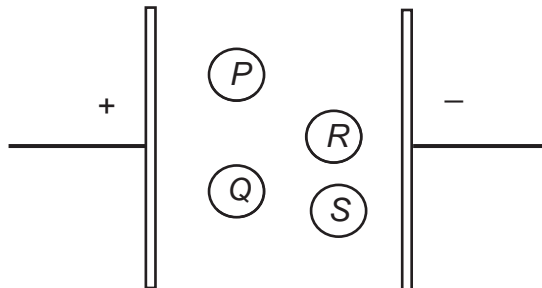

Which particles experienced the same force due to electric field?

- A** *P* and *Q*
B *R* and *S*
C All of them
D None of them

- 32** A piece of wire has a resistance of 16Ω . The wire is 20 cm long and has a cross-sectional area of 2.0 mm^2 .

Which wire of the same material has a resistance of 8.0Ω ?

	length	cross-sectional area
A	10 cm	0.5 mm^2
B	10 cm	1.0 mm^2
C	20 cm	0.5 mm^2
D	20 cm	4.0 mm^2

- 33** A defibrillator is a device that is used to give an electric shock to a patient's heart. It supplies an electric shock of energy 300 J at an average voltage of 2000 V for 10 ms.

What is the average current it supplies?

- A** 0.015 A
B 0.67 A
C 6.7 A
D 15 A
- 34** The diagram shows the circuit for a hair-dryer.

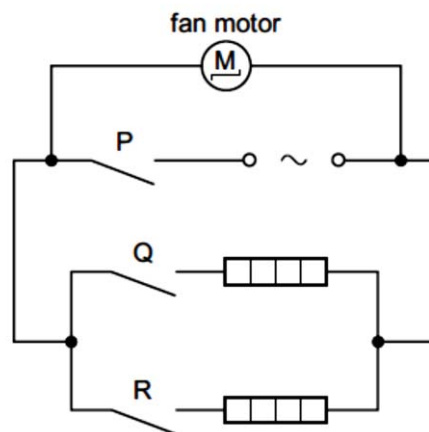

The fan motor has a power rating of 0.10 kW and the heaters each have a rating of 0.40 kW. The cost of electricity is 18 cents per kWh.

What is the cost of running the hair-dryer for two hours with switches P and Q closed and switch R open?

- A** 9 cents
B 18 cents
C 24 cents
D 32 cents

- 35** The current in a kettle is 10 A and the kettle is protected by a 13 A fuse. The owner of the kettle replaces the 13 A fuse with a 3 A fuse.

What happens when the kettle is switched on?

- A** The fuse does not melt and the kettle works correctly.
- B** The fuse does not melt but the kettle fails to work.
- C** The fuse melts and the kettle is undamaged.
- D** The fuse melts and the kettle might be damaged.

- 36** An old lamp is found and a new filament bulb with a power rating of 500 W is inserted. When the lamp is plugged into the mains and switched on, it does not light up.

What is a possible cause of this?

- A** The earth wire in the plug is disconnected.
- B** The fuse in the circuit has too high a rating.
- C** The neutral wire in the plug is disconnected.
- D** The lamp is doubly insulated.

- 37** A beam of electrons is travelling towards the right. The electrons subsequently move past a solenoid connected to a d.c. source.

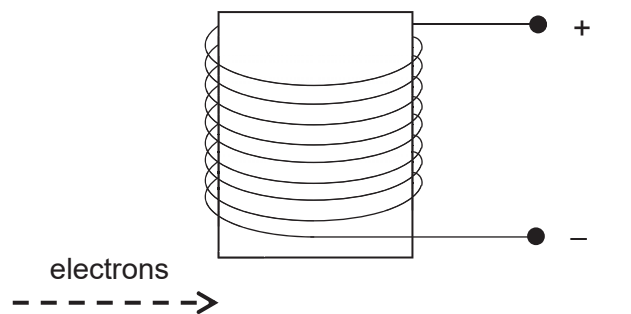

Assuming that the electrons have negligible mass, in which direction will the beam of electrons be deflected?

- A** downwards
- B** into the page
- C** out of the page
- D** upwards

- 38** A magnet moves up and down above a coil of wire. The bottom of the magnet moves up and down between P and R.

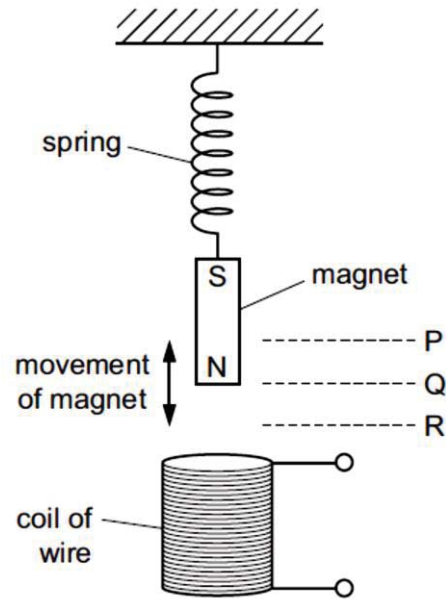

Where is the bottom of the magnet when the induced electromotive force (e.m.f.) in the coil is maximum?

- A** P
- B** Q
- C** R
- D** P and R

- 39 The graph shows the voltage induced by an a.c. generator that varies with time.

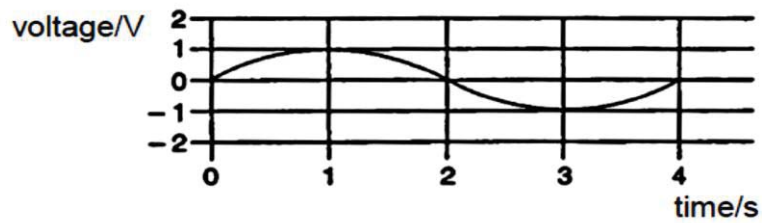

If the number of turns in the coil is increased four times and the speed of the rotation of the coil is halved, what will be the new waveform shown on the CRO?

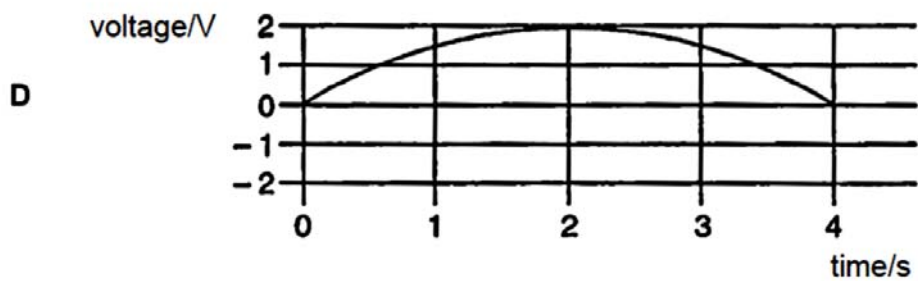
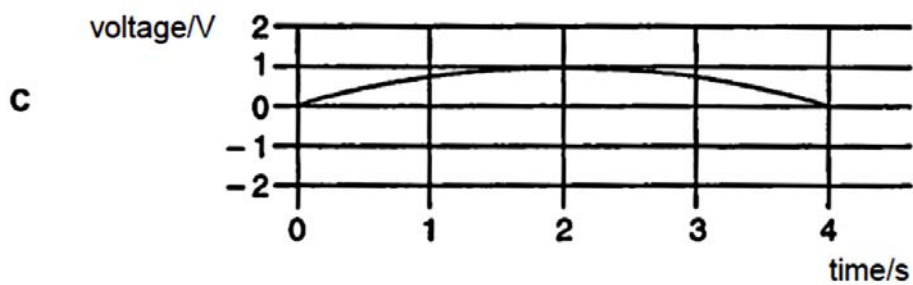
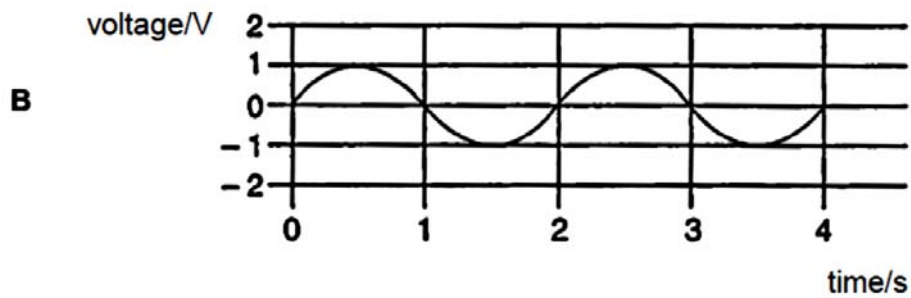
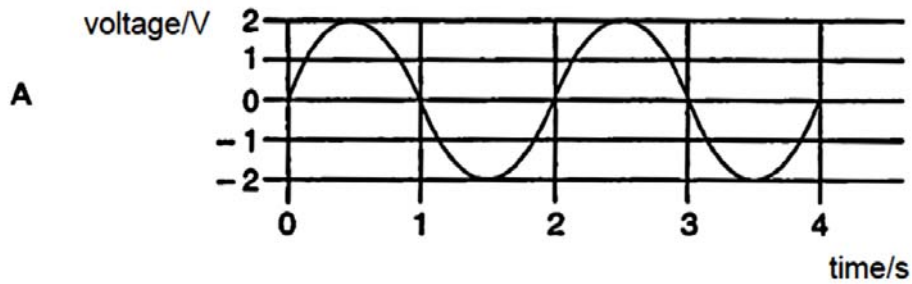

- 40 The diagram shows many small identical bulbs connected to an ideal transformer of turns ratio 1:4. The bulbs are rated at 2.0 V, 2.0 W.

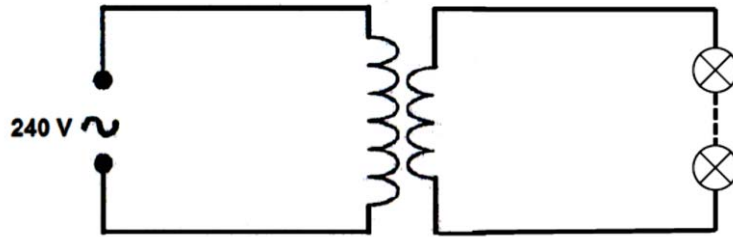

To operate the bulbs at normal brightness, how many bulbs can be connected to the secondary side of the transformer and what is the primary current?

	number of bulbs	primary current / A
A	30	0.25
B	30	0.50
C	60	0.50
D	120	4.00

Name _____ ()

Class _____

PRELIMINARY EXAMINATION
GENERAL CERTIFICATE OF EDUCATION ORDINARY LEVEL

PHYSICS
Paper 2

6091/02
20 August 2019
1 hour 45 minutes

READ THESE INSTRUCTIONS

Write your name and index number on all the work you hand in. Write in dark blue or black pen in the spaces provided on the Question Paper. You may use a soft pencil for any diagrams or graphs. You may use geometrical instruments and electronic calculators. Do not use highlighters, correction fluid or correction tape.

Section A [50 marks]

Answer **ALL** questions.

Section B [30 marks]

Answer **ALL** questions. Question 11 has a choice of parts to answer.

Information for students:

Students are reminded that all quantitative answers should include appropriate units and should be given to a sensible number of significant figures. Errors in units and numbers of significant figures will be penalised. If working is needed for any question, it must be shown in the space provided. Omission of essential working will result in loss of marks.

The number of marks is given in brackets [] at the end of each question or part question.

For Examiner's Use	
Section A (50 Marks)	
Section B (30 Marks)	
Total (80 Marks)	

This document consists of **21** printed pages and **1** blank page.



圣尼各拉女校
CHIJ ST NICHOLAS GIRLS' SCHOOL
Girls of Grace · Women of Strength · Leaders with Heart

[Turn over]

Section A (50 marks)

Answer **all** the questions in this section in the spaces provided.

- 1 Fig 1.1 shows a crane, with a “wing” attachment on its side, lifting a load.

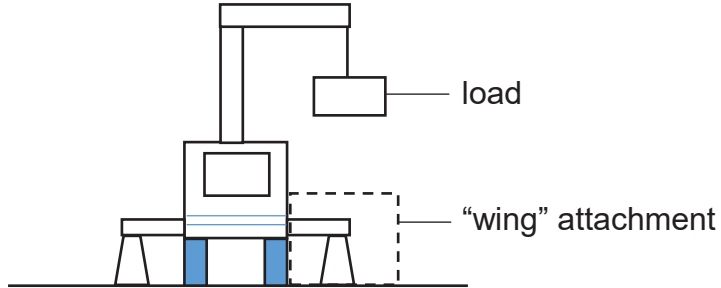

Fig 1.1

- (a) Explain the purpose of this “wing” attachment.

.....

[2]

- (b) On a windy day, the 25 kN load experiences a force of 50 kN to the east, as shown in Fig 1.2.

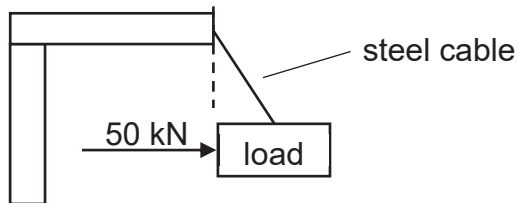

Fig 1.2

Using a scaled vector diagram, determine the tension in the steel cable.

tension = [3]

2 A piece of ice, with a mass of 22 g, at a temperature of $-12.0\text{ }^{\circ}\text{C}$ is placed in a container containing water at $22.0\text{ }^{\circ}\text{C}$.

- (a)** Given that the specific heat capacity of ice is $2100\text{ J}/(\text{kgK})$ and the latent heat of fusion of ice is $3.3 \times 10^5\text{ J}/\text{kg}$, calculate the heat needed
- (i)** to raise the temperature of ice from $-12.0\text{ }^{\circ}\text{C}$ to $0\text{ }^{\circ}\text{C}$.

heat = [2]

- (ii)** to change the ice at $0\text{ }^{\circ}\text{C}$ to water at $0\text{ }^{\circ}\text{C}$.

heat = [2]

(b) The temperature of the water in the container falls after ice has been added.

- (i)** Given that the specific heat capacity of water = $4200\text{ J}/(\text{kgK})$, calculate the initial mass of water in the container if the final temperature of the mixture is $8.0\text{ }^{\circ}\text{C}$.

initial mass of water = [2]

- (ii)** State an assumption you have made in **(b)(i)**.

.....
 [1]

- 3 A light dependent resistor (LDR) is used to turn on a lamp in another circuit when it gets dark. Part of the circuit is shown in Fig 3.1.

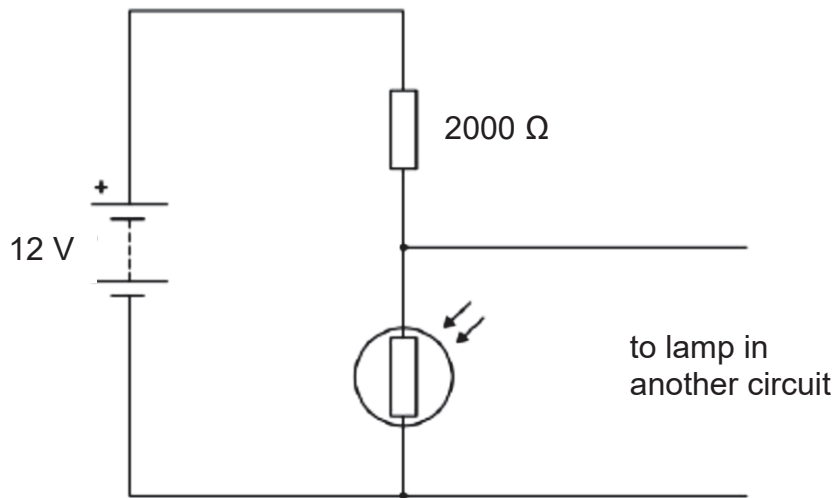

Fig 3.1

- (a) The light intensity decreases. State and explain what happens to the potential difference across the LDR.

.....

[2]

- (b) Calculate the resistance of the LDR when the current flowing through it is 4.0 mA.

resistance = [2]

- (c) The electrical circuit in Fig 3.1 is now altered such that the LDR is removed and 3 other resistors are added, as shown in Fig 3.2.

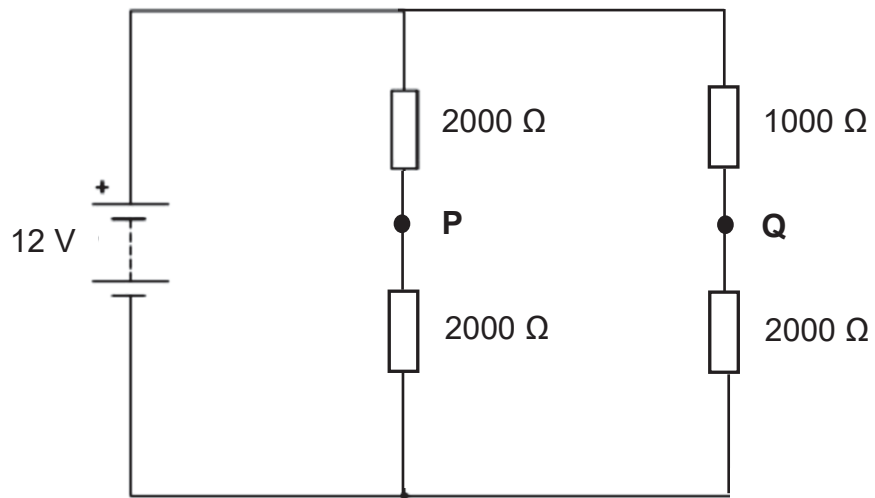

Fig 3.2

- (i) Calculate the effective resistance of the circuit in Fig 3.2.

effective resistance = [2]

- (ii) Compare the current flowing through point P and point Q. Explain your answer.

.....

[2]

- 4 Jamie bought a tea kettle with a dull black external surface, as shown in Fig 4.1. The tea kettle uses an electric element to heat water and its power output is 2.8 kW.



Fig 4.1

- (a) State the energy change that takes place when the tea kettle is used to heat up the water.

..... [1]

- (b) Suggest a modification which can be made to the tea kettle such that the water in the kettle can remain hot for a longer period of time.

.....
 [1]

- (c) An electricity retailer passes the cost due to transmission loss to the consumers. The transmission loss factor for the current year is 1.03.

Given that the tea kettle is used for 10 minutes daily and the cost per unit of electricity charged by this electricity retailer is 18 cents, calculate the cost of using this tea kettle daily for one week.

cost = [2]

- (d) The mains voltage supply for the tea kettle is 230 V. Suggest a suitable fuse rating for the tea kettle.

fuse rating = [2]

- 5 Fig. 5.1 shows a method to paint a metal panel using electrostatic charges. The nozzle of the spray gun is connected to a high voltage electrode which applies positive charges to the paint droplets. The metal panel is connected to earth.

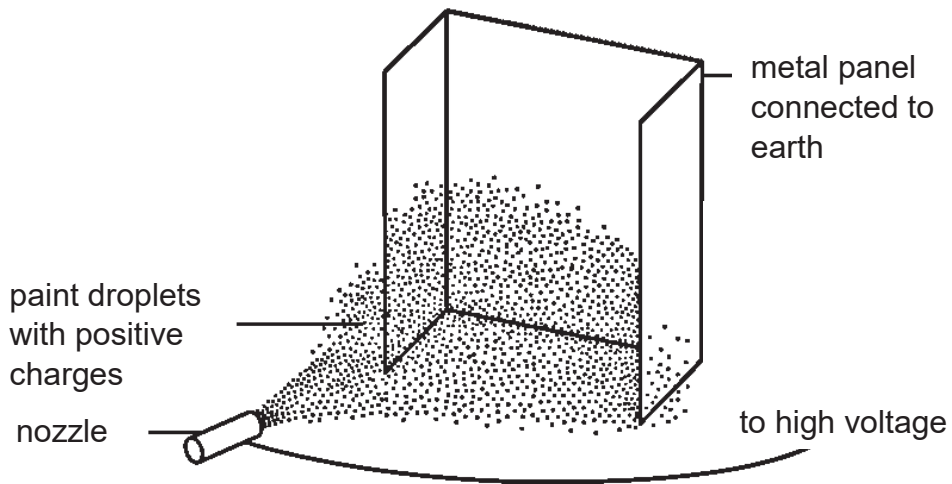

Fig 5.1

- (a) Explain why the paint droplets spread out as they leave the nozzle.

.....
 [1]

- (b) Explain why this method of painting reduces the amount of paint lost.

.....

 [2]

- (c) Another type of spray gun does not make use of electrical voltage to charge the paint. However, the paint droplets are still charged positively as they leave the nozzle. Suggest how the paint droplets become positively charged as they leave the nozzle.

.....

 [2]

- 6 (a) Fig 6.1 shows a series of lines representing a longitudinal wave set up in a long spring (slinky).

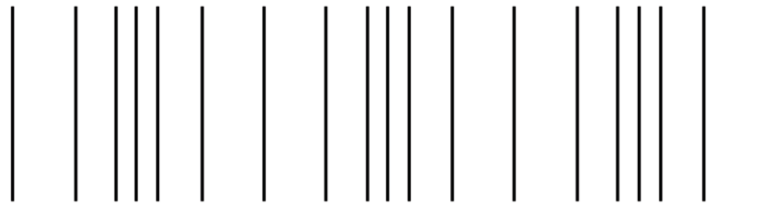

Fig 6.1

- (i) Describe how a longitudinal wave could be set up in the spring.

.....
 [1]

- (ii) On Fig 6.1, mark
 1. a position of compression and rarefaction with the letter "C" and "R" respectively and [1]
 2. a distance to represent the wavelength of the wave with an arrow. [1]

- (b) Fig 6.2 represents a cross-section of the water waves.

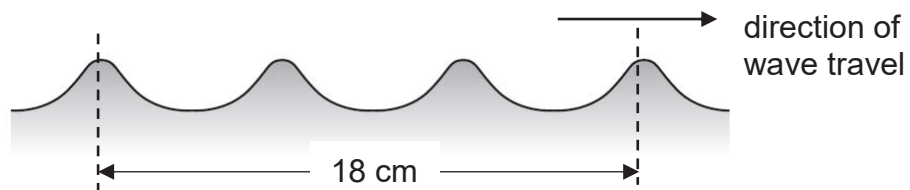

Fig 6.2

The water waves has a frequency of 5.0 Hz.

(i) Calculate the speed of the water waves in cm/s.

speed = [2]

(ii) The wave as shown in Fig 6.2 travels into a shallow region. State and explain what happens to

1. frequency and
2. wavelength of the wave in the shallow region.

1. [1]

2. [1]

7 Fig 7.1 shows white light incident on the top face of a diamond. The white light is dispersed into its various rays. Only the red (R) and blue (B) light rays are shown in Fig 7.1.

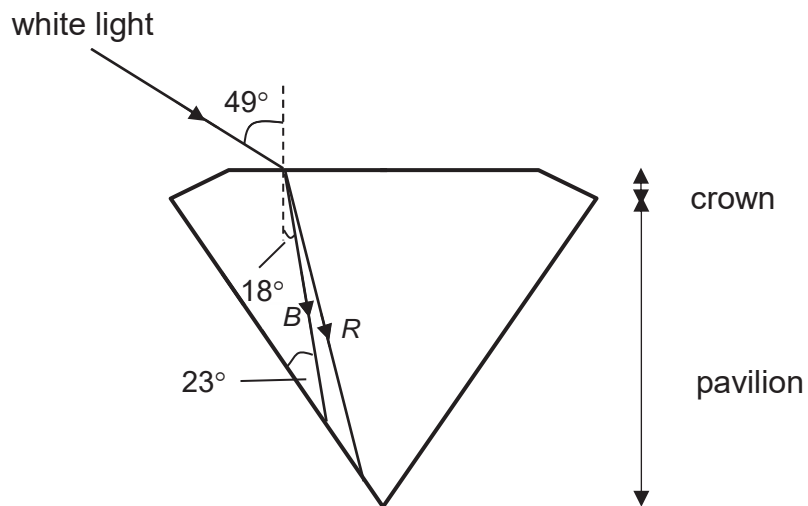

Fig 7.1 (not to scale)

(a) Explain why white light disperses in diamond, as shown in Fig 7.1.

.....
.....
..... [2]

(b) (i) Calculate the refractive index of diamond for blue light.

refractive index = [2]

(ii) Given that the speed of light in air is 3.0×10^8 m/s, calculate the speed of blue light in the diamond.

speed of blue light in diamond = [1]

(c) The diamond is now submerged in water. If the white light is still incident on the top face of the diamond at the same angle, explain what happens to the path of the blue light ray in the diamond.

.....
.....
.....
..... [2]

- 8 (a) A student has 3 identical metal bars. Two of the metal bars are magnets and one is not. Explain, with the aid of a diagram, how the student can identify the two magnets without using any other apparatus.

.....

 [2]

- (b) State a type of metal that can be used to make a permanent magnet.
 [1]

- (c) (i) Fig 8.1 shows a vertical wire passing through a horizontal piece of card.

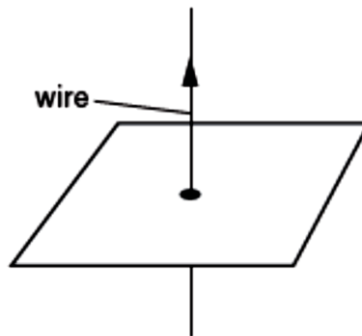

Fig 8.1

There is a direct current (d.c.) in the wire, which produces a magnetic field around it. Suggest how the magnetic field produced by the current-carrying wire can be investigated.

.....
 [1]

- (ii) Fig 8.2 shows the wire and the card viewed from above.

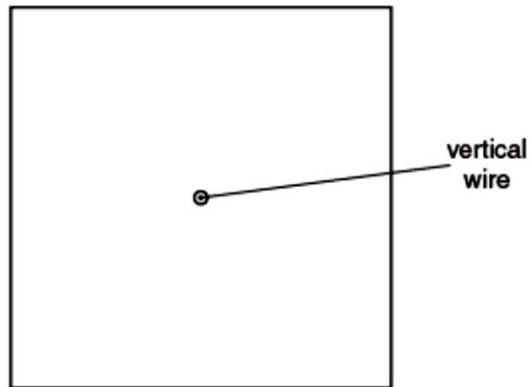

Fig 8.2

On Fig 8.2, draw three complete field lines produced by the current-carrying wire.

[1]

Section B (30 marks)

Answer **all** the questions in the spaces provided.

Answer only one of the two alternative questions in **Q11**.

- 9 Fig 9.1 shows a rollercoaster train being pulled horizontally to the right by a cable.



Fig 9.1

Fig 9.2 shows information on the train.

speed / m/s	8.3	8.3	8.3	16.6	24.9	33.2	41.5
time / s	0.0	0.5	1.0	1.5	2.0	2.5	3.0

Mass of empty train: 1500 kg
 Mass of fully loaded train : 1800 kg
 Total length: 10.5 m
 Number of wheels: 16

Fig 9.2

- (a) Describe the motion of the train from $t = 0.0$ s to $t = 3.0$ s.

.....

.....

.....

.....

[2]

- (b) (i) Determine the average tension in the cable pulling a fully loaded train during $t = 1.0 \text{ s}$ to $t = 3.0 \text{ s}$.

average tension = [3]

- (ii) Is the actual average tension higher, lower or the same compared to your answer in (b)(i)? Explain your answer.

.....
.....
.....
..... [2]

- (c) Calculate the distance the train travelled from $t = 0.0 \text{ s}$ to $t = 3.0 \text{ s}$.

distance = [2]

- (d) One of the passenger claims that if the tension in the cable remains constant and the number of passengers is halved, the acceleration of the train will be doubled. Explain whether the claim is true.

.....
..... [1]

- 10 (a) Fig 10.1 shows the structure of a simple a.c. generator.

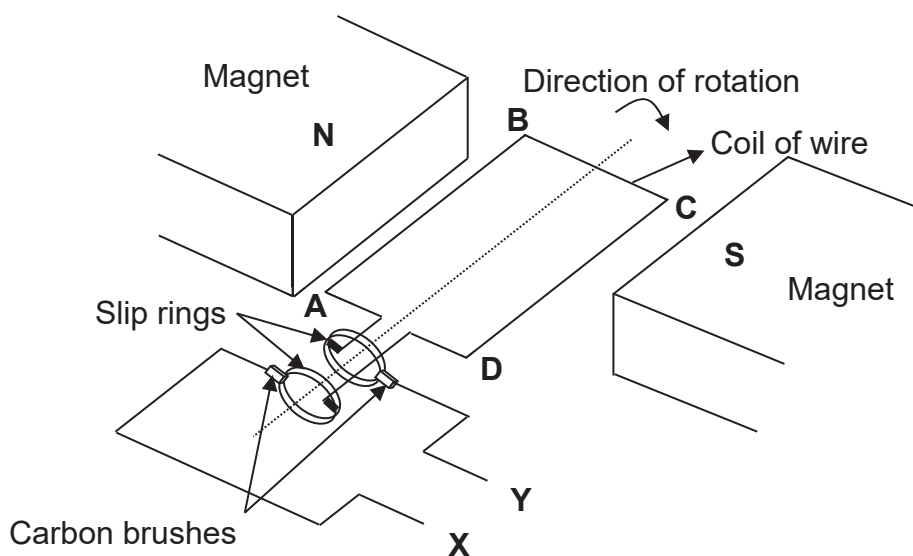
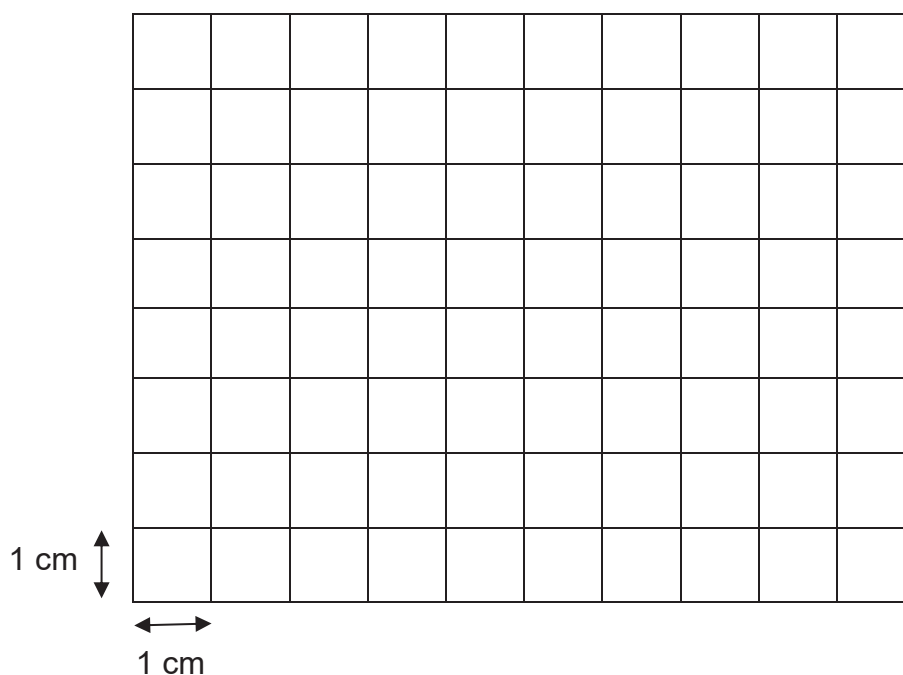

Fig 10.1

The two ends of the wires, X and Y are the output terminals which are connected to a cathode ray oscilloscope (CRO). The coil is turned by a water wheel at 50 Hz. The peak voltage of the output is 9.0 V.

The time base of CRO is switched on at 10 ms/cm and Y-gain is set at 3 V/cm.

- (i) Sketch the trace of the output from the generator on CRO.



[2]

- (ii) Explain how the generator gives the output in (a)(i).

.....

.....

.....

.....

.....

.....

.....

[3]

- (iii) Sketch the new trace of the output display when the slip rings are replaced by a split-ring commutator.

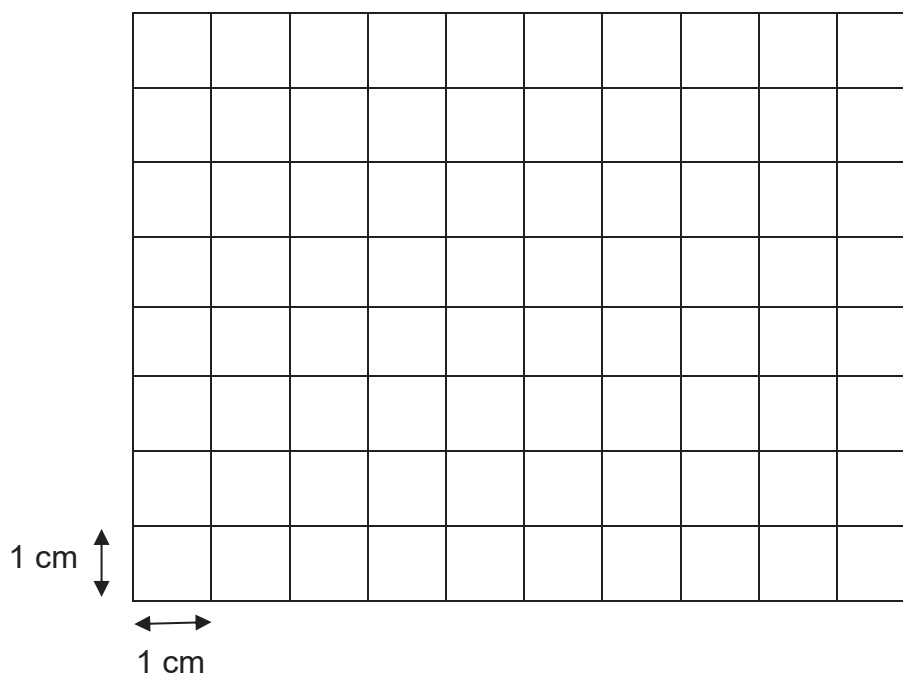

[1]

- (b) Fig 10.2 shows an electric guitar, with strings that are already magnetised. A coil is placed near each string. Fig 10.3 shows that the coil is connected to a loudspeaker, which produces the sound of the guitar.

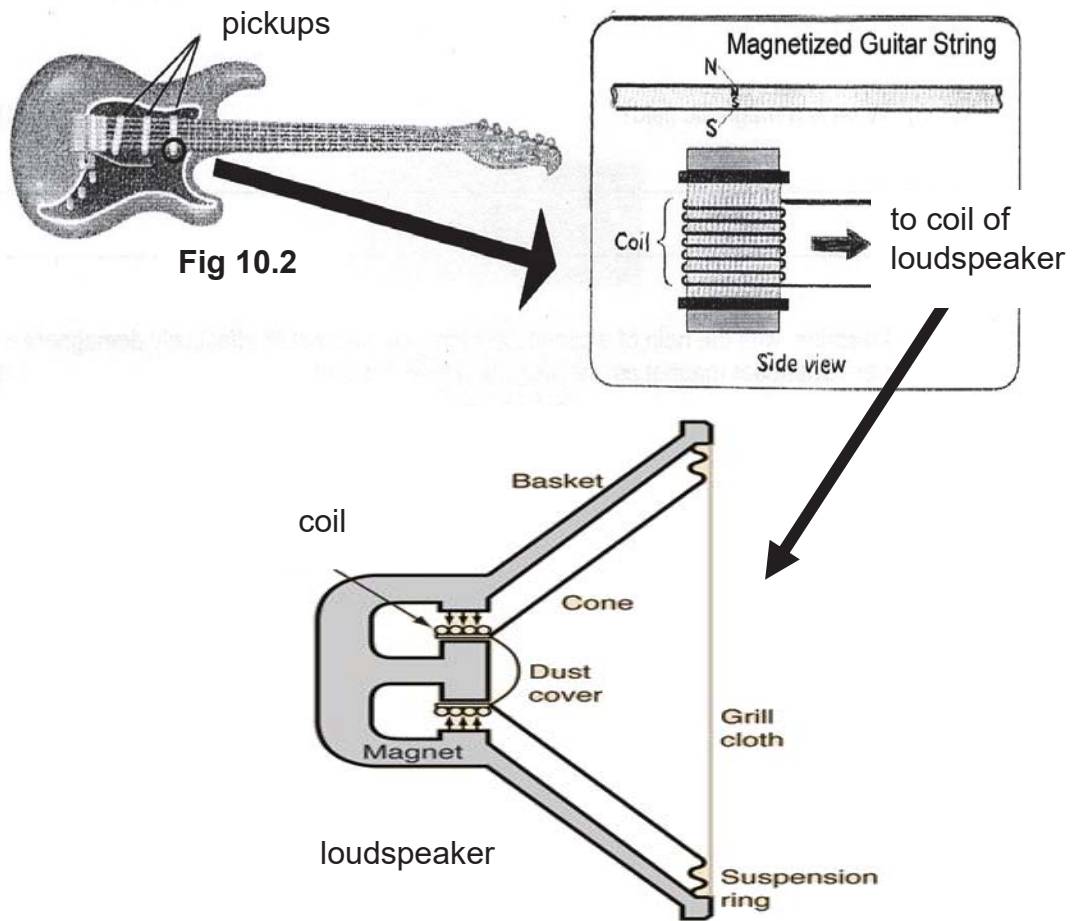

Fig 10.3

- (i) Explain how the coil in Fig 10.2 can detect the vibration in the magnetised string when it is plucked.

.....

[2]

- (ii) Explain how the loudspeaker, a moving-coil device, produces the sound of the electric guitar.

.....

[2]

11 EITHER

(a) Fig 11.1 shows a simple d.c. motor. The ends of the single loop coil ABCD are soldered to the split-ring commutators. Two batteries are connected in the external circuit.

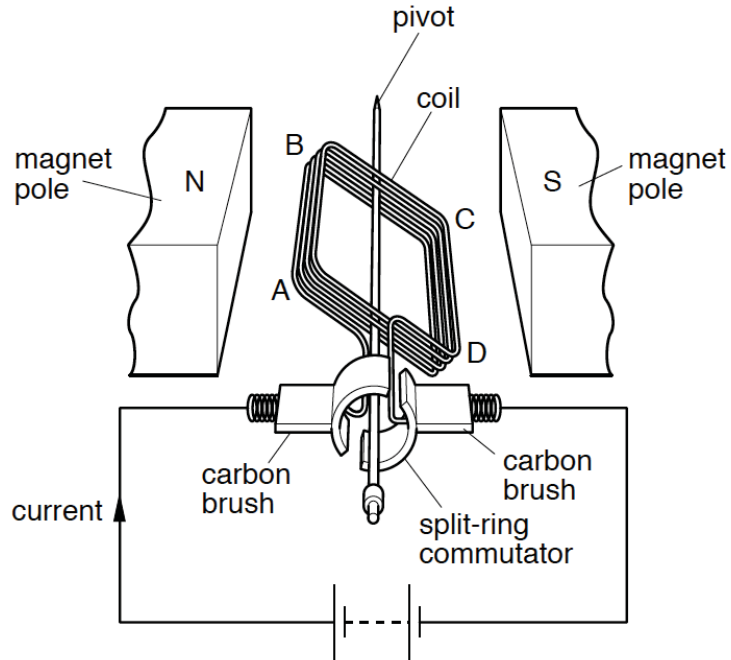

Fig 11.1

(i) State the direction of rotation of the coil when viewed from the commutator.

..... [1]

(ii) Explain how this d.c. motor works and the purpose of the split-ring commutator.

.....

.....

.....

.....

.....

.....

.....

..... [3]

- (b) Jamie designs a simple doorbell using materials found in the Physics laboratory, as shown in Fig 11.2. When switch S is pressed and then released, two sound notes of identical frequency are produced.

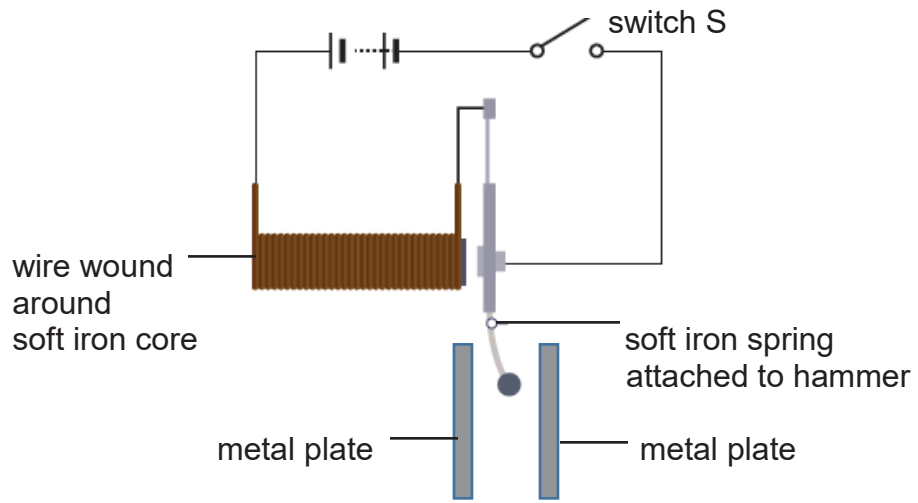

Fig 11.2

- (i) Explain how the two sound notes are produced.

.....

.....

.....

..... [2]

- (ii) Jamie makes the following comment: “The bell will still work if the battery is replaced with an a.c. source.”
Do you agree? Explain your answer.

.....

.....

.....

..... [2]

- (iii) Suggest two ways to increase the loudness of the bell.

.....

..... [2]

11 OR

Fig 11.3 shows a diving bell with a hatch of outer surface area 0.50 m^2 . While the bell is on the surface of the sea, the hatch is closed and sealed.

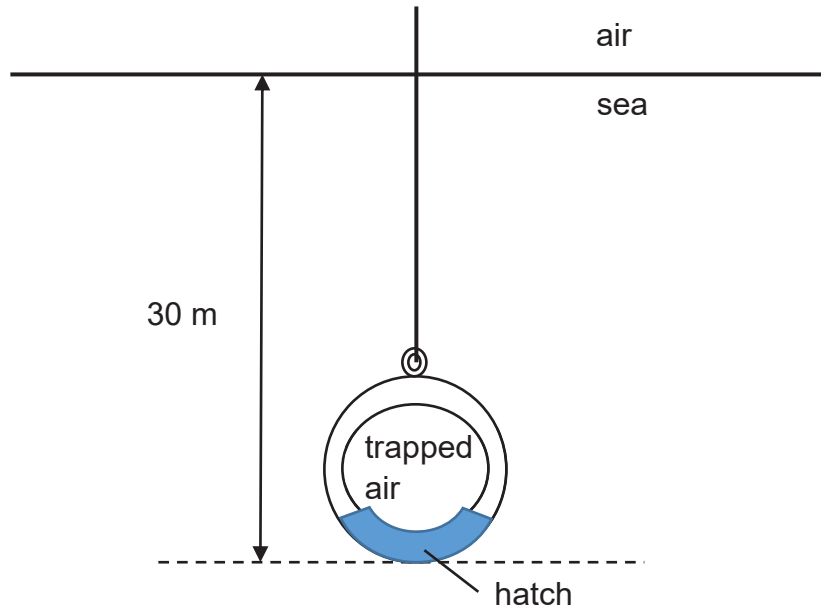

Fig 11.3 (not to scale)

(a) The bell is lowered from the surface of the sea to a depth of 30 m. The pressure of the atmosphere is $100\,000 \text{ Pa}$ and the density of the seawater is 1100 kg/m^3 . The gravitational field strength g is 10 N/kg .

(i) Define *pressure*.

.....
 [1]

(ii) Calculate the pressure exerted on hatch by the water when it is at a depth of 30 m.

pressure = [2]

(iii) Hence, calculate the force acting on the hatch.

force = [1]

- (iv) Explain what happens to the volume of the trapped air when the hatch is opened at 30 m below the surface of the sea. Assume that the trapped air in the bell is at atmospheric pressure before the hatch is opened.

.....
.....
.....

[2]

- (b) The same diving bell is lowered to the same depth of 30 m in another region of the sea. It was observed that the volume of trapped air is more than the volume in (a)(iv) when the hatch opens. Suggest a possible reason for the observation.

.....
.....

[1]

- (c) Using kinetic theory of matter, explain why the pressure of the trapped air in the bell rises when its temperature increases.

.....
.....
.....
.....
.....
.....

[3]

----- END OF PAPER -----

