

Visit

FREETESTPAPER.com

for more papers



Website: [freetestpaper.com](http://www.freetestpaper.com)



[Facebook.com/freetestpaper](https://www.facebook.com/freetestpaper)



[Twitter.com/freetestpaper](https://www.twitter.com/freetestpaper)



**SINGAPORE CHINESE GIRLS' SCHOOL
PRELIMINARY EXAMINATION 2019
SECONDARY FOUR**

CANDIDATE NAME

CLASS

4		
---	--	--

CENTRE NUMBER

--	--	--	--

REGISTER NUMBER

--	--

INDEX NUMBER

--	--	--	--

PHYSICS **6091/1**

Wednesday **4 September 2019** **1 hour**

Additional Materials: Multiple Choice Answer Sheet

READ THESE INSTRUCTIONS FIRST

Write in soft pencil.

Do not use staples, paper clips, glue or correction fluid.

Write your name, class and index number on the Question Paper **and** Answer Sheet in the spaces provided.

There are **forty** questions in this paper. Answer **all** questions. For each question, there are four possible answers, **A, B, C, D**.

Choose the **one** you consider correct and record your choice in **soft pencil** on the separate Answer Sheet.

Read the instructions on the Answer Sheet very carefully.

Each correct answer will score one mark. A mark will not be deducted for a wrong answer.

Any rough working should be done in this booklet.

The use of an approved scientific calculator is expected, where appropriate.

Take $g = 10 \text{ ms}^{-2}$ or 10 Nkg^{-1} unless specified otherwise.

This question paper consists of 22 pages

- 1 A micrometer screw gauge is used to measure the diameter of a copper wire.

The reading with the wire in position is shown in diagram 1. The wire is removed and the jaws of the micrometer are closed. The new reading is shown in diagram 2.

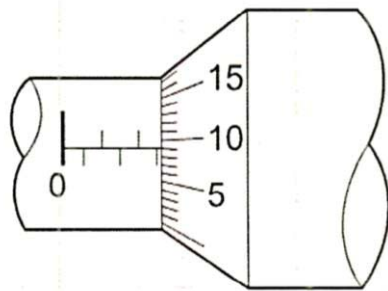

diagram 1

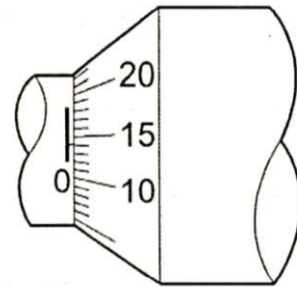
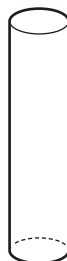

diagram 2

What is the diameter of the wire?

- A 1.90 mm
 - B 2.45 mm
 - C 2.59 mm
 - D 2.73 mm
- 2 Two cylinders P and Q are made of copper.



P

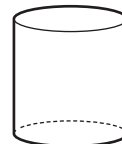

Q

The height of P is twice the height of Q. The diameter of P is half the diameter of Q.

Which statement is correct?

- A The density of cylinder P is four times that of cylinder Q.
- B The density of cylinder P is twice that of cylinder Q.
- C The density of cylinder P is equal to that of cylinder Q.
- D The density of cylinder P is half that of cylinder Q.

- 3 The diagram shows two objects on a beam balance.

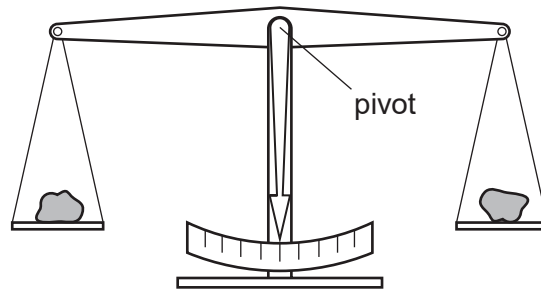

The beam balance is in equilibrium.

Which quantities may be different?

- A The masses of the two objects
 - B The moments about the pivot of the two objects
 - C The volumes of the two objects
 - D The weights of the two objects
- 4 A kite is in equilibrium at the end of a string, as shown.

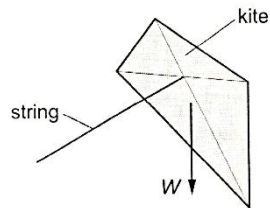

The kite has three forces acting on it: its weight W , the tension T in the string, and the force F from the wind.

Which vector diagram represents the forces acting on the kite?

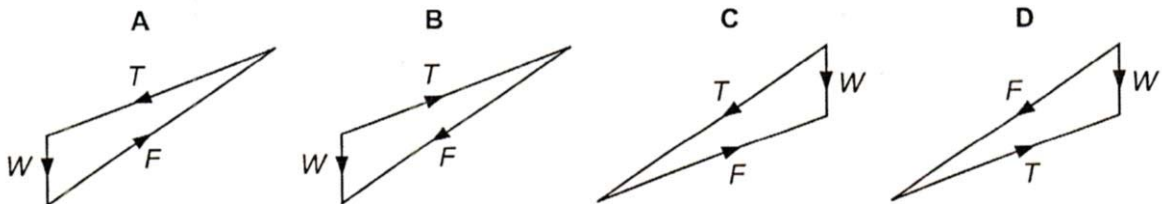

- 5 A stone of mass m is dropped from a tall building. There is significant air resistance. The acceleration of free fall is g .

When the stone is falling at a constant (terminal) velocity, which information is correct?

	magnitude of the acceleration of the stone	magnitude of the force of gravity on the stone	magnitude of the force of air resistance on the stone
A	g	zero	mg
B	zero	mg	mg
C	zero	zero	mg
D	zero	mg	zero

- 6 The velocity-time graph for an object is shown.

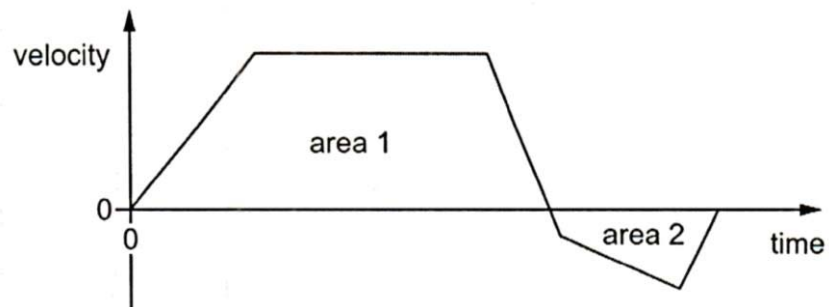

How can the total displacement of the object be determined?

- A** area 1 – area 2
B $(\text{area 1} + \text{area 2}) \div 2$
C area 1 + area 2
D area 2 – area 1

- 7 A ball is released from rest above a horizontal surface. It strikes the surface and bounces several times.
The velocity-time graph for the first two bounces is shown.

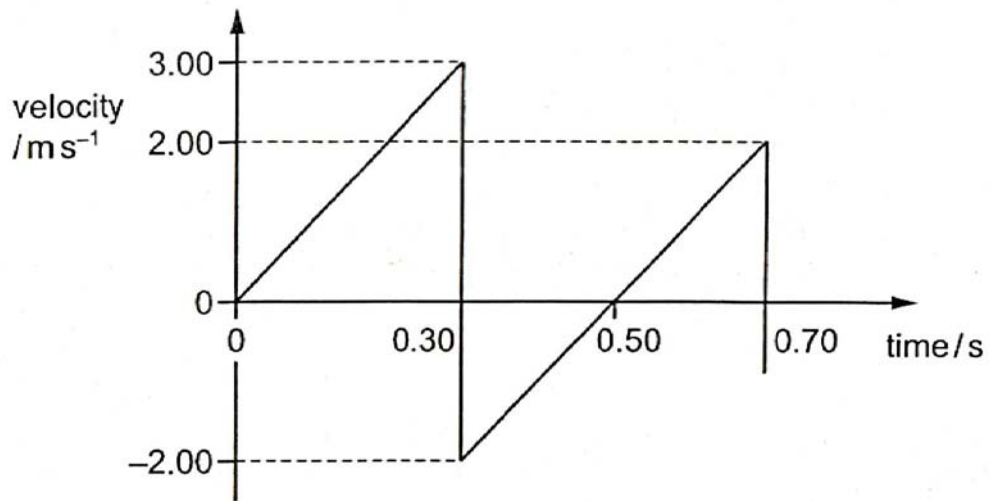

What is the maximum height of the ball after the first bounce?

- A 0.20 m B 0.25 m C 0.45 m D 0.65 m
- 8 What is not the definition of power?
- A force \times displacement
B force \times velocity
C voltage \times current
D work done \div time

- 9 A bus takes 25 s to reach a constant speed while travelling in a straight line. A graph of speed v against time t is shown.

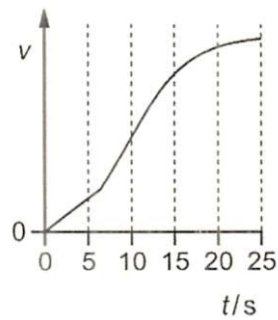

Which graph shows the variation of the resultant force F on the bus with t ?

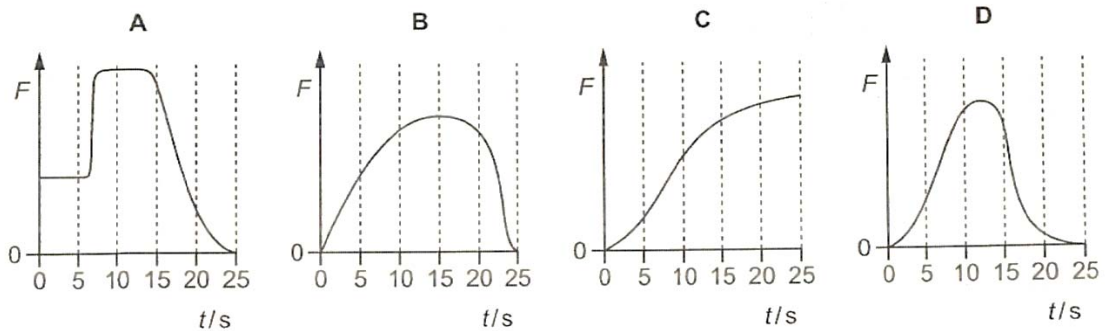

- 10 A stone is released at a great height in air and falls due to gravity. Each of the three graphs below represents the variation of one of the three variables p , q and r with time.

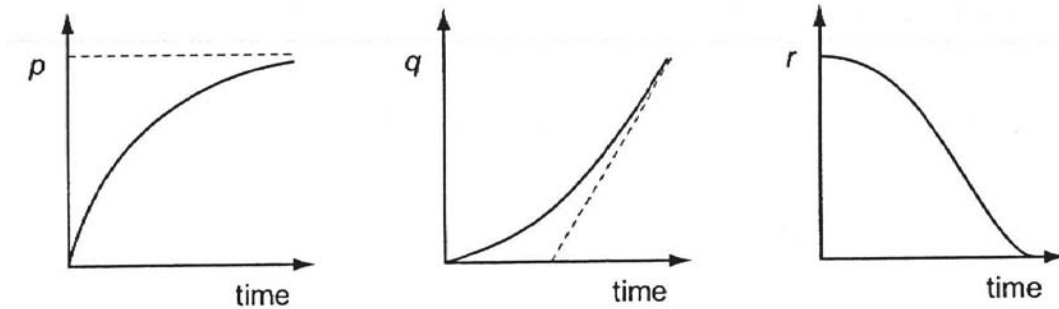

Which row correctly identifies the three variables p , q and r ?

	p	q	r
A	acceleration	displacement	velocity
B	displacement	velocity	acceleration
C	velocity	acceleration	displacement
D	velocity	displacement	acceleration

- 11 An engine pulls a truck at constant speed on a level track.

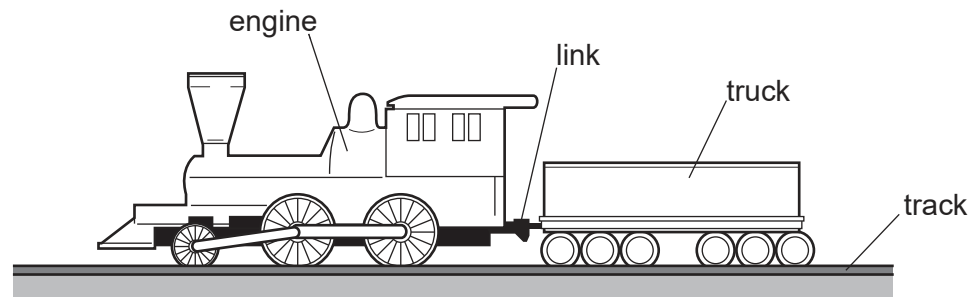

The link between the engine and the truck breaks. The driving force on the engine remains constant.

What effect does this have on the engine and on the truck?

	engine	truck
A	speed stays constant	slows down
B	speeds up	slows down
C	speed stays constant	stops immediately
D	speeds up	stops immediately

- 12 The diagram shows a uniform beam PQ. The length of the beam is 3.0 m and its weight is 50 N. The beam is supported on a pivot 1.0 m from end P. A load of weight W is hung from end P and the beam is in equilibrium.

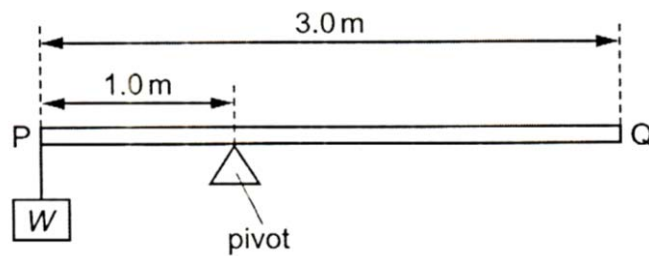

What is the value of W ?

- A** 25 N **B** 50 N **C** 75 N **D** 100 N

- 13 A uniform rectangular board is supported by a frictionless pivot at its centre point P.

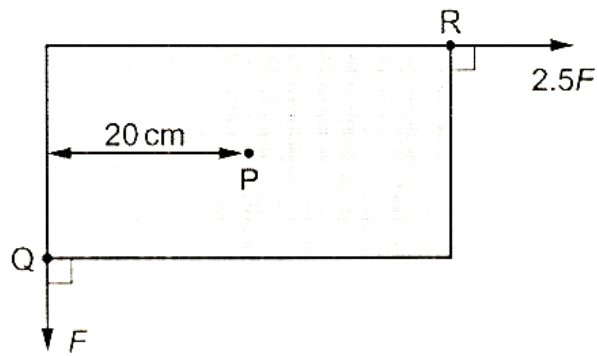

Two forces act in the plane of the board. Force F acts at corner Q and a force $2.5F$ acts at corner R. The perpendicular distance between the line of action of the force F and the point P is 20 cm. The board is in equilibrium.

What is the area of the board?

- A 160 cm² B 320 cm² C 640 cm² D 1600 cm²
- 14 A car of mass 500 kg is at rest at point X on a slope, as shown.

The car's brakes are released and the car rolls down the slope with its engine switched off. At point Y the car has moved through a vertical height of 30 m and has a speed of 11 ms⁻¹.

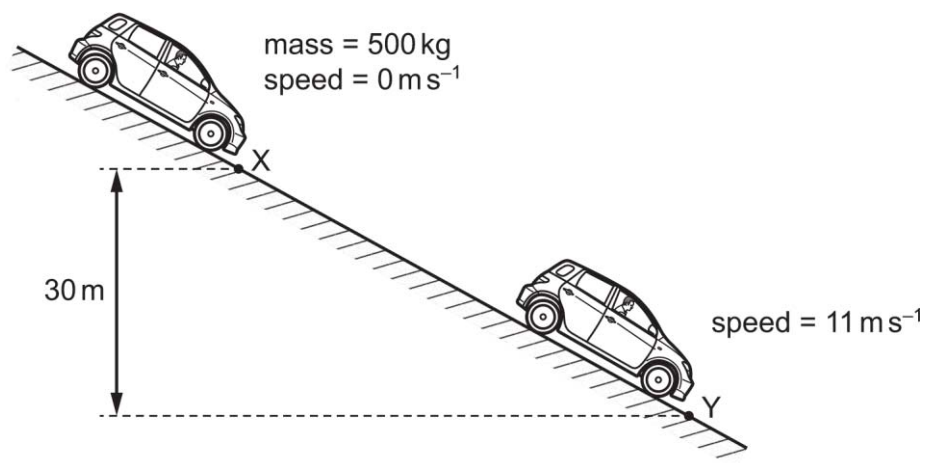

What is the energy dissipated by frictional forces when the car moves from X to Y?

- A 3.0×10^4 J B 1.2×10^5 J C 1.5×10^5 J D 1.8×10^5 J

15 In which situation is there no work done?

- A** A man carrying two luggage bags and walking up a slope
- B** A ball is dropped and falls to the ground
- C** A box moves at constant speed across a smooth horizontal surface
- D** A crane lifting a steel beam at constant speed

16 A rocket is fired vertically upwards.

As it accelerates upwards after leaving the launch pad, which forms of energy are changing?

- A** Chemical energy, gravitational potential energy and kinetic energy
- B** Chemical energy and gravitational potential energy only
- C** Chemical energy and kinetic energy only
- D** Gravitational potential energy and kinetic energy only

17 A crane lifts a weight of 600 N through a vertical height of 30 m in 25 s. The efficiency of the crane is 40%.

What is the total power input of the crane?

- A** 0.29 kW
- B** 0.72 kW
- C** 1.8 kW
- D** 1800 kW

20 Which lens does not show rays of light passing through a converging lens?

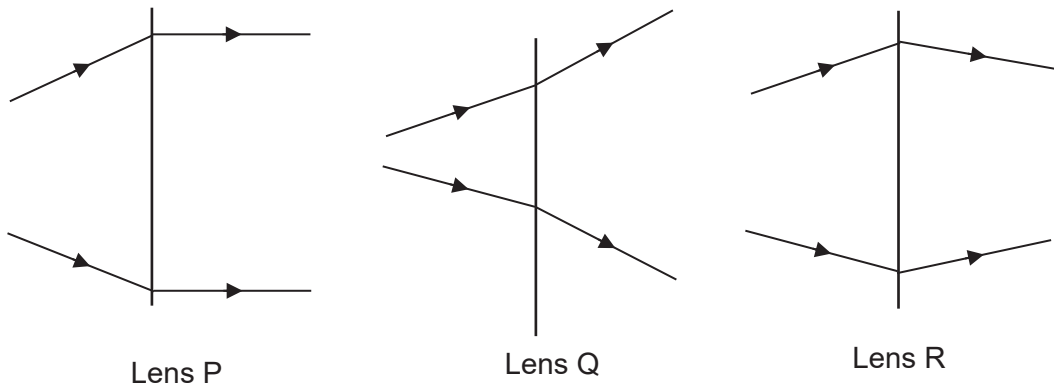

- A Lens Q only
 B Lens P and Q only
 C Lens Q and Lens R only
 D Lens P and Lens R only

21 Vertical beams of light are incident on the horizontal faces of three plastic prisms, X, Y and Z. The refractive index of plastic is 1.8.

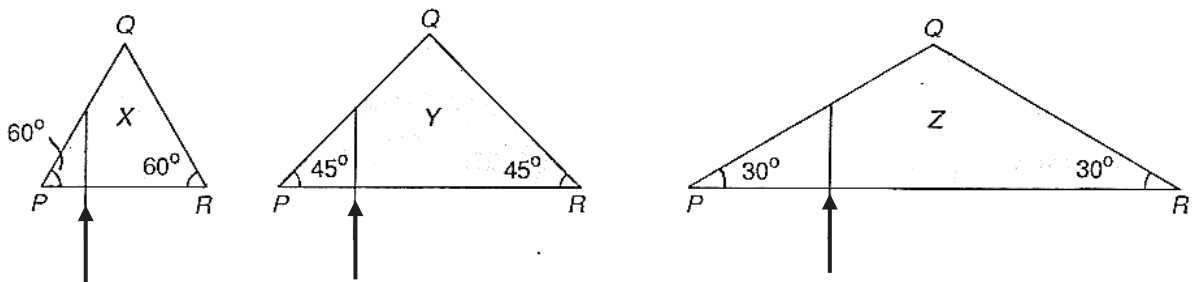

In which prism(s) will total internal reflection occur at the surface PQ?

- A X but not Y and Z
 B X and Y but not Z
 C Y and Z but not X
 D X, Y and Z

- 22** Containers A and B are filled with equal amounts of hot water at the same temperature. The temperature of the water in the containers are measured with a thermometer some time later. It is observed that container A has a much lower temperature than container B.

What are the possible reasons?

- (i) Container A is painted black and container B is painted white
- (ii) Container A has a lid and container B is not covered
- (iii) Container A is made of aluminium and container B is made of plastic

- A** (i) and (ii) only
- B** (i) and (iii) only
- C** (ii) and (iii) only
- D** (i), (ii) and (iii)

- 23** A thin tube contains a thread of mercury which traps air at the end of the tube. The other end of the tube is open to the atmosphere.

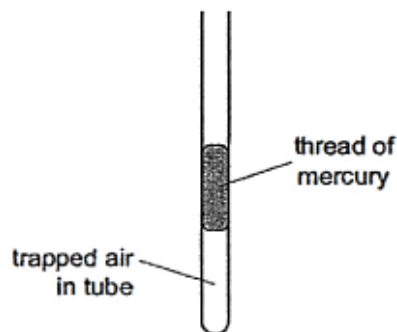

When the tube is turned upside down,

- A** the volume of the trapped air increases because the pressure in the trapped air is reduced.
- B** the volume of the trapped air increases because the atmosphere pushes less when it acts upwards on the mercury.
- C** the volume of the trapped air decreases because the pressure in the trapped air is reduced.
- D** the volume of the trapped air decreases because gravitational force acting on the mercury increases when the tube is turned upside down.

- 24** Equal masses of three liquids X, Y and Z are heated from room temperature. Energy is supplied by heating at the same rate to each liquid. The graph shows how the temperature of each liquid varies with time after heating starts.

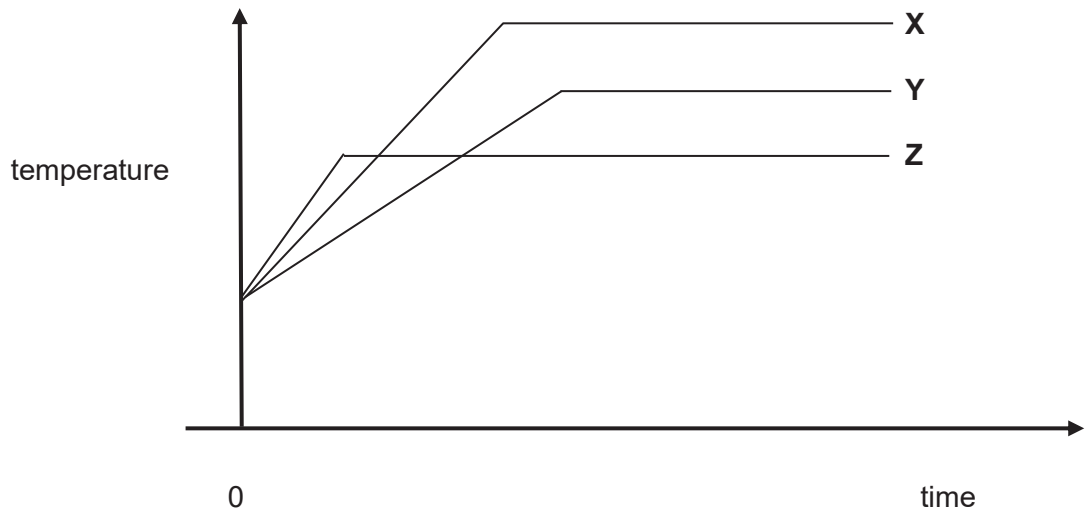

What can be deduced from the graph?

- A** X has the highest melting point.
 - B** X gains the most internal energy.
 - C** Y has the largest specific heat capacity.
 - D** Z has the smallest specific latent heat of vaporisation.
- 25** Using an electric kettle, 200 g of water at 100 °C is converted into steam at 100 °C in 300 seconds. The specific latent heat of steam is 2250 J/g.

What is the average electrical power used?

- A** 1.5 W
- B** 1500 W
- C** 3380 W
- D** 135 MW

- 26** A new liquid is tested to decide whether it is suitable for use in a liquid-in-glass thermometer. It is found that the liquid does not expand uniformly with temperature.

What will be effect of this on the scale of the thermometer?

- A** It will have a short range.
 - B** The markings will be too far apart.
 - C** The markings will be too close together.
 - D** The markings will be spaced unevenly.
- 27** An astronaut wishes to communicate with his fellow astronauts inside the space shuttle some distance away.

Which two waves, in the correct nature and sequence, are being used during the communication?

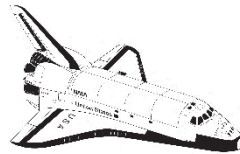

- A** transverse → longitudinal
- B** longitudinal → transverse
- C** transverse → longitudinal → transverse
- D** longitudinal → transverse → longitudinal

- 28 Graph 1 shows how the displacement of one particular point of a wave varies with time.
Graph 2 shows how the displacement of the same wave varies with distance along the wave at one particular time.

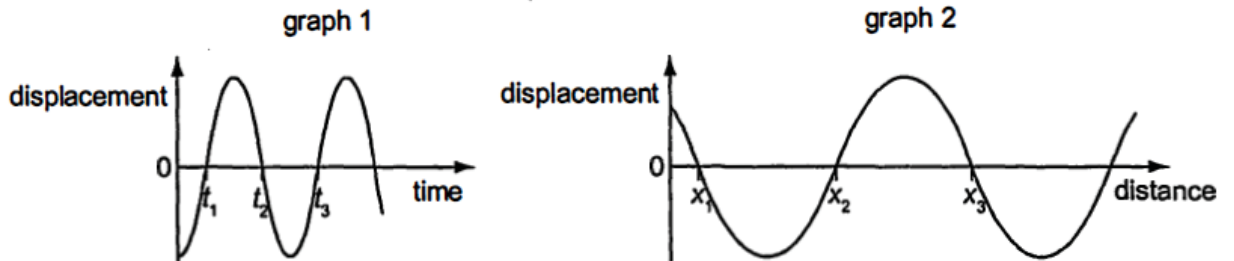

Which expression gives the speed of the wave?

- A $\frac{x_1}{t_1}$ B $\frac{x_2}{t_2 - t_1}$ C $\frac{x_2 - x_1}{t_2}$ D $\frac{x_3 - x_2}{t_2 - t_1}$

- 29 A guitar player struck a note on a guitar string. The same string is then struck harder.

Which of the following correctly compares the speed and wavelength of the second note with the first note?

	Speed	Wavelength
A	same	same
B	same	different
C	different	same
D	different	different

- 30** In normal light, the resistance of a light-dependent resistor (LDR) is R . It is connected in the circuit with two resistors, each of resistance R . The currents in the two resistors are I_1 and I_2 as shown.

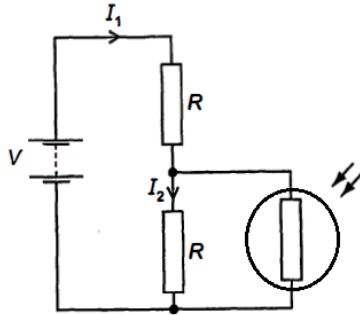

How do the currents change when the circuit is moved to a brighter place?

	I_1	I_2
A	increase	increase
B	increase	decrease
C	decrease	decrease
D	decrease	increase

- 31 The graph shows the current-voltage (I-V) characteristics of two resistors R and X.

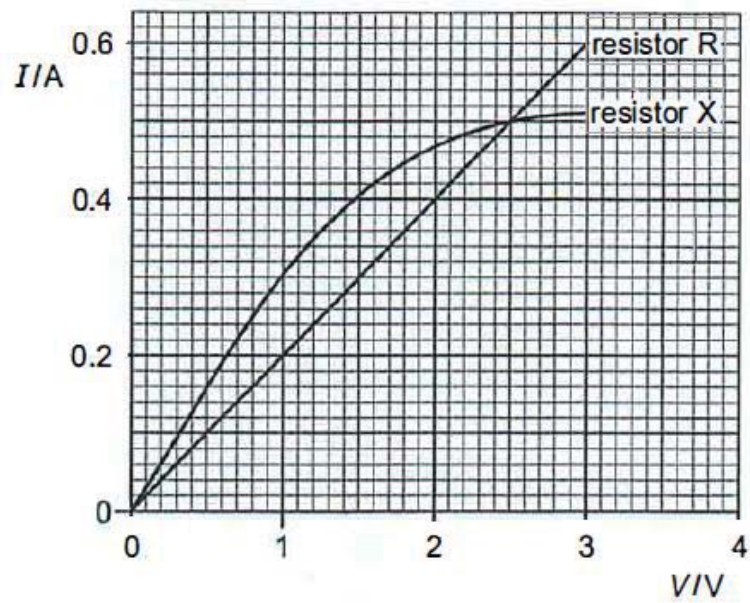

The resistors R and X are connected in series with a cell. The current in the circuit is 0.3A.

The resistors R and X are then connected in parallel with the same cell.

What is the e.m.f. of the cell and the current in the cell when the resistors are connected in parallel?

	e.m.f. / V	current / A
A	1.0	0.3
B	1.5	0.7
C	2.5	0.5
D	2.5	1.0

- 32 Which is a consequence of connecting several electrical appliances to the same power socket?
- A Current drawn by each appliance is increased.
 B Total resistance of all appliances is increased.
 C Voltage drawn by each appliance is decreased.
 D Total energy consumption is increased.
- 33 A current of 40 mA passes through a slice of semi-conducting material of dimensions as shown.

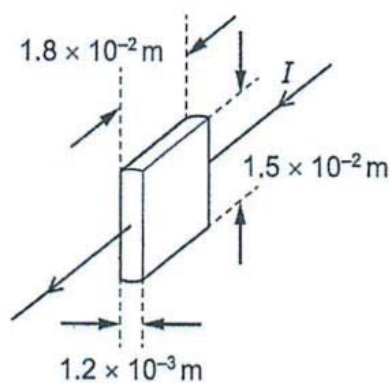

The slice dissipates 400 mW of heat energy.

What is the resistivity of the semiconductor under these conditions?

- A 0.25 Ωm
 B 0.36 Ωm
 C 56 Ωm
 D 380 Ωm
- 34 Three conductors are placed close to each other. Conductor X is negatively-charged. Both conductors Y and Z are neutral.

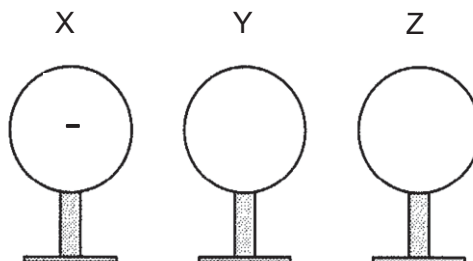

What will be the charge in conductor Z after it is being earthed momentarily?

- A neutral B positive C negative D no charge

35 In which circuit is the voltmeter reading 7.2 V?

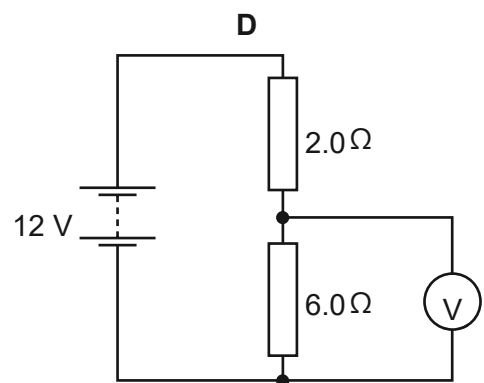
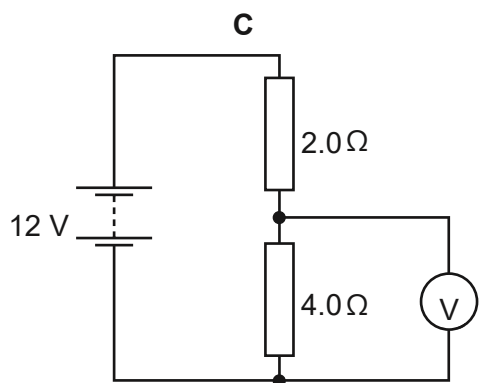
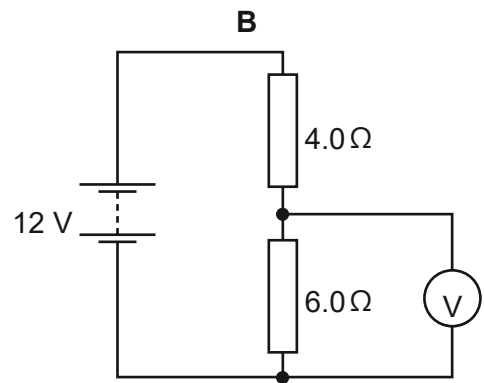
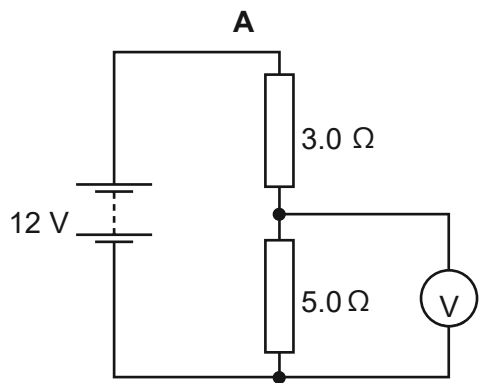

36 The diagram shows a simple d.c. motor.

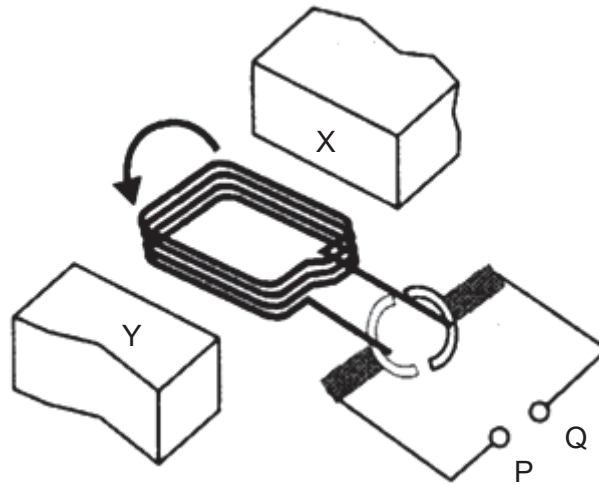

Which combination(s) will achieve the direction of rotation shown in the diagram?

	Polarity	Direction of current
1	X is S-pole, Y is N-pole	P is +, Q is -
2	X is N-pole, Y is S-pole	P is -, Q is +
3	X is N-pole, Y is S-pole	P is +, Q is -

- A** 2 only
- B** 1 and 2 only
- C** 2 and 3 only
- D** 1 and 3 only

37 Copper rods P and Q are placed on top of rigid bare wires as shown.

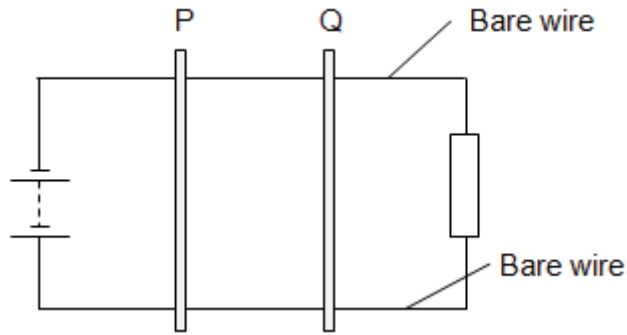

Which observation is correct when the power supply is changed to a low frequency alternating current ?

- A P and Q attract each other.
- B P and Q repel each other.
- C P and Q repel then attract each other.
- D P and Q both roll to the right and then to the left, keeping the same distance apart.

38 The graph below shows how the e.m.f. of an A.C. generator varies with time.

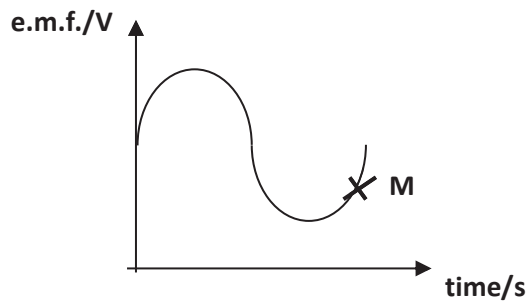

The diagrams below show the front view of the coil of an A.C. generator. The coil is being rotated about an axis through O in a uniform magnetic field. Which of them shows the position of the coil when the value of the induced emf is at M?

A		B	
C		D	

- 39 The diagram shows an ideal transformer. An a.c. supply of 100 V is supplied to the primary coil. A current of 0.5 A flows through it.

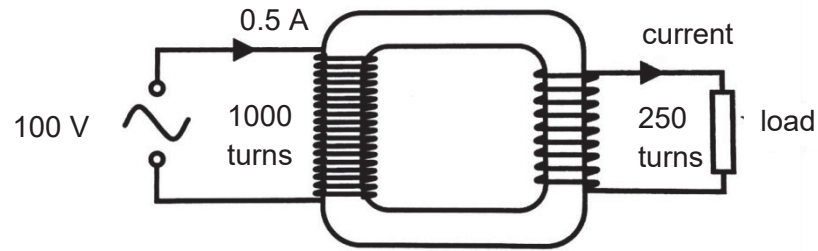

What is the potential difference and current flowing through the load?

	potential difference / V	current / A
A	25	2
B	25	4
C	50	2
D	50	4

- 40 A teacher moves a magnet into and out of a coil of wire, as shown, in order to demonstrate electromagnetic induction.

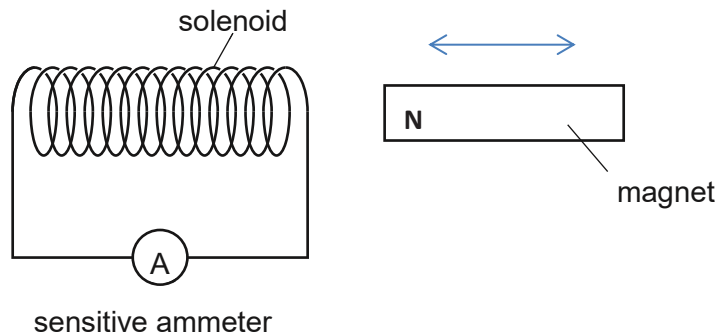

Which statement is correct?

- A** As the magnet is moved into the coil, the right-hand end of the coil becomes a S-pole.
- B** As the magnet is taken out of the coil, the right-hand end of the coil becomes a N-pole.
- C** Increasing the speed at which the magnet enters the coil increases the induced voltage.
- D** Increasing the speed at which the magnet leaves the coil decreases the induced voltage.

END OF PAPER



**SINGAPORE CHINESE GIRLS' SCHOOL
PRELIMINARY EXAMINATION 2019
SECONDARY FOUR**

CANDIDATE NAME

--

CLASS

4		

CENTRE NUMBER

REGISTER
NUMBER

INDEX NUMBER

PHYSICS

6091/2

Monday

2 September 2019

1 hour 45 mins

Candidates answer on the Question Paper.
No Additional Materials are required.

READ THESE INSTRUCTIONS FIRST

Section A

Answer **all** questions.

Section B

Answer **all** questions. Question 11 has a choice of parts to answer.

Candidates are reminded that **all** quantitative answers should include appropriate units.
The use of an approved scientific calculator is expected, where appropriate.
Candidates are advised to show all their working in a clear and orderly manner, as more marks are awarded for sound use of Physics than for correct answers.

The number of marks is given in brackets [] at the end of each question or part question.

Take $g = 10 \text{ ms}^{-2}$ or 10 Nkg^{-1} unless stated otherwise.

For Examiner's Use	
Section A	50
Section B	30
Total	80

This question paper consists of 27 printed pages and 1 blank page.

SECTION A

Answer all the questions in this section.

- 1 A steel ball of mass 250 kg is suspended from the boom of a crane, as shown in **Fig. 1.1**.

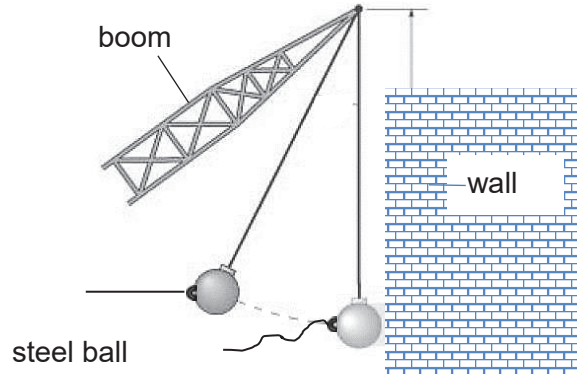

Fig. 1.1

- (a) In order to demolish a wall, the ball is pulled from the wall at an angle and then released and hits the wall. The variation of the speed v of the ball with time t is shown in **Fig. 1.2**.

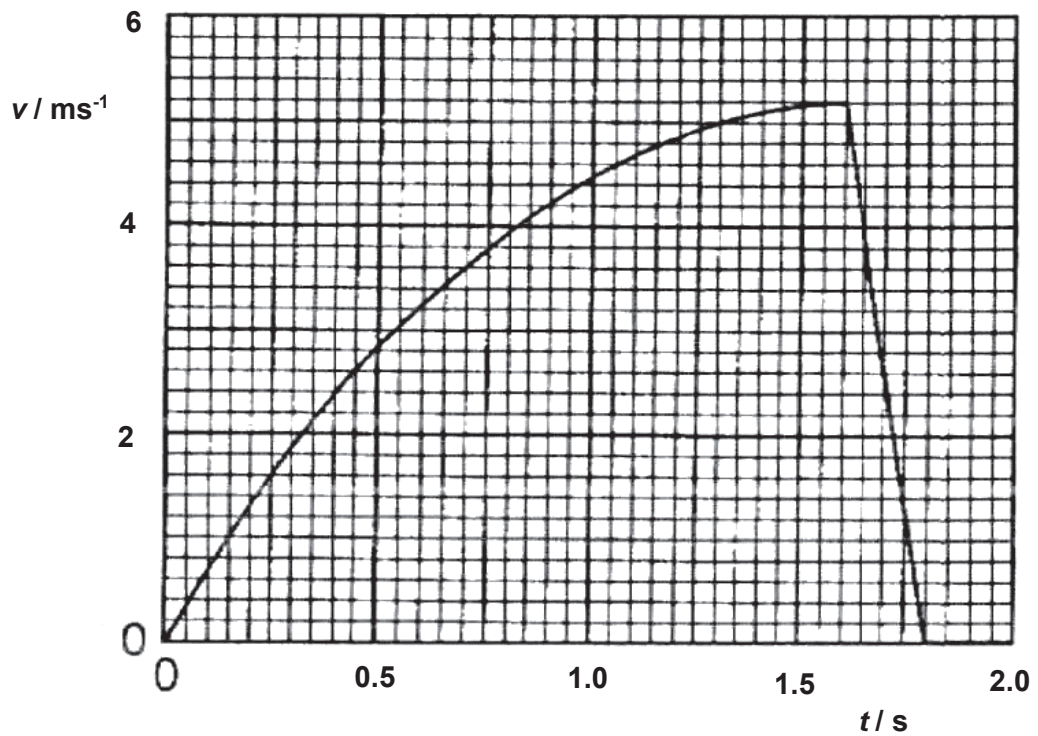

Fig. 1.2

Using **Fig. 1.2**, determine

- (i) the magnitude of the acceleration of the ball at time $t = 0.8$ s.

Acceleration =[2]

- (ii) the total distance moved by the ball from the moment of release to when it comes to rest.

Distance moved =[2]

- (b) Explain why the steel ball undergoes decreasing acceleration after it is released, and then uniformly decelerates till it comes to rest.

.....

.....

.....

.....

.....[2]

[Total: 6 m]

2 A model rocket of initial mass 1.3 kg is fired vertically into the air. Its mass decreases at a constant rate of 0.23 kg s^{-1} as the fuel burns. The final mass of the rocket is 0.38 kg.

(a) Calculate the weight of the fuel being burnt off.

Weight of fuel being burnt off =[1]

(b) The variation with time t of the upward force on the rocket during the first 3 seconds after firing is shown in Fig. 2.1. The dotted line from 3.0 – 3.5 s is the predicted variation of the upward force on the rocket with time t .

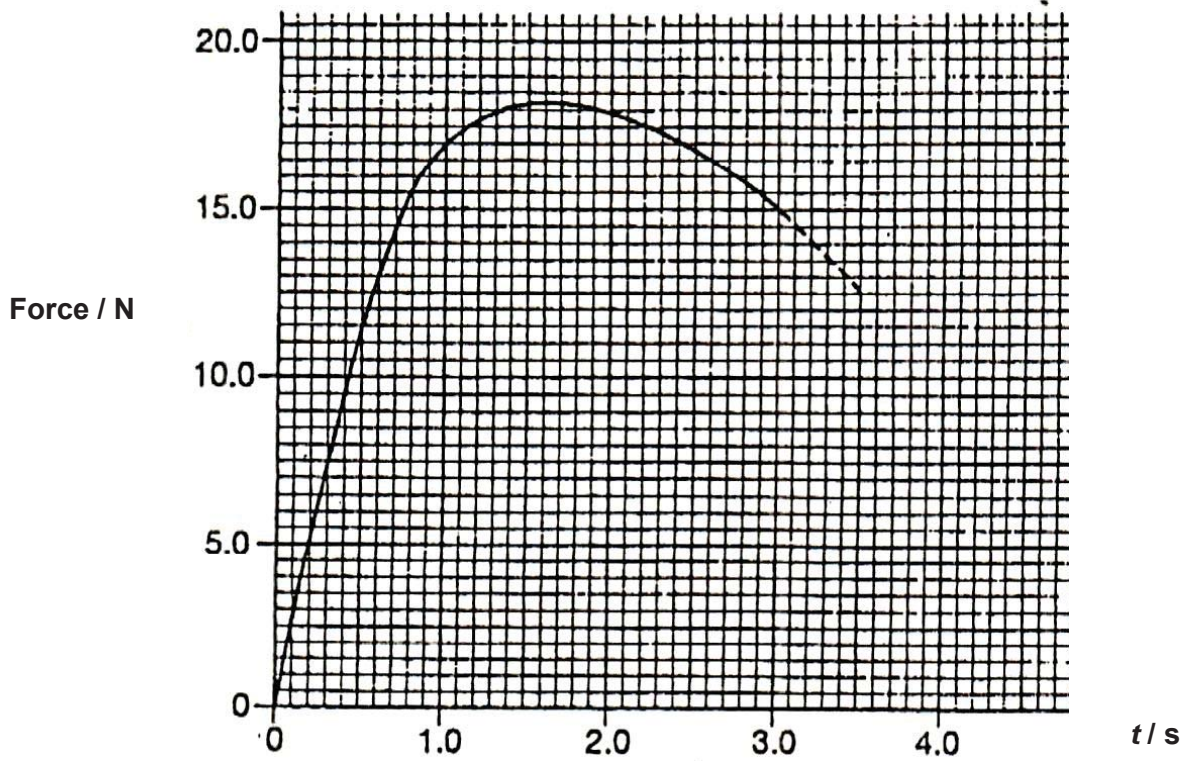

Fig. 2.1

On Fig. 2.1, draw a line drawn to represent the variation with time t of the total weight of the rocket during the first 5 seconds after firing. [2]

- (c) (i) From the graph drawn in Fig. 2.1, read off the time delay between firing the rocket and lift-off.

Time delay = [1]

- (ii) Determine the resultant force acting on the rocket at $t = 2.5$ s. Show clearly how you arrived at your answer in the space below.

Resultant force =[2]

[Total : 6 m]

3 Fig. 3.1 shows a student sitting on a chair. Fig. 3.2 shows the same student with his chair tilted backwards slightly. The four legs of the chair are identical.



Fig. 3.1



Fig. 3.2

(a) (i) State and explain how the pressure of the chair on the floor differs in the two positions.

.....
.....
.....
.....[2]

(ii) The chair and student fall over if the chair is tilted backwards more than in Fig. 3.2. Explain why.

.....
.....
.....
.....
.....[3]

(b) Fig. 3.3 shows a painter standing on a wooden plank, directly above the right-hand support.

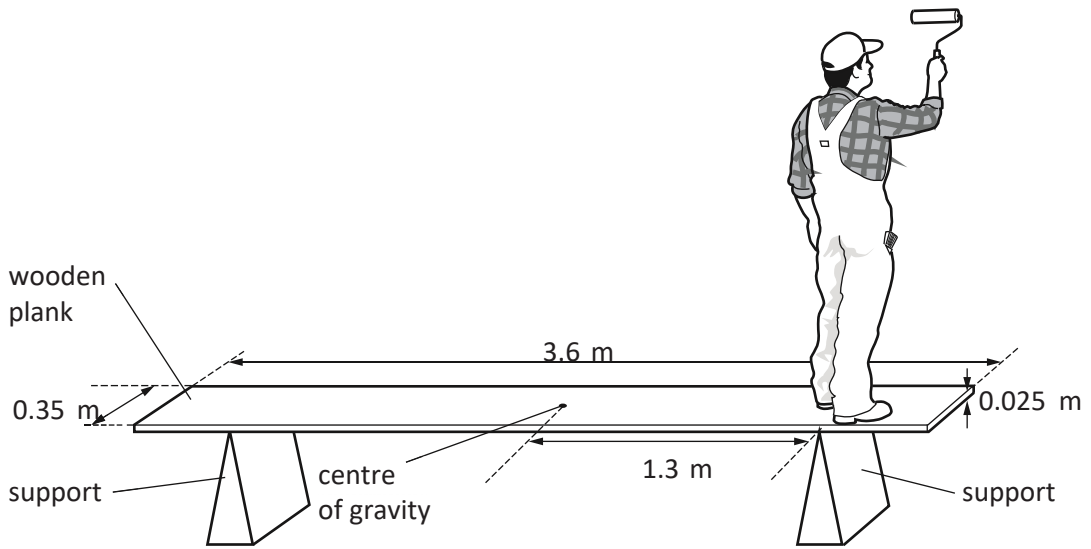

Fig. 3.3

The plank has a length of 3.6 m and a mass of 23 kg. The centre of gravity of the plank is in the middle of the plank at a distance of 1.3 m from each of the supports. The gravitational field strength g is 10 N / kg.

(i) Calculate the moment of the plank about the right-hand support.

moment = [1]

(ii) The painter moves further to the right along the plank and the plank rotates about the right hand support.

Explain why the plank rotates.

.....

[1]

[Total : 7 m]

- 4 A lamp is positioned at the bottom of a small pool of water. The *critical angle* for light passing from water into air is 49° .

(a) Explain what is meant by the term *critical angle*.

.....

[1]

(b) The lamp sends light towards the surface of the pool.

Fig. 4.1 shows three rays of light that are at 30° , 60° and 90° to the horizontal.

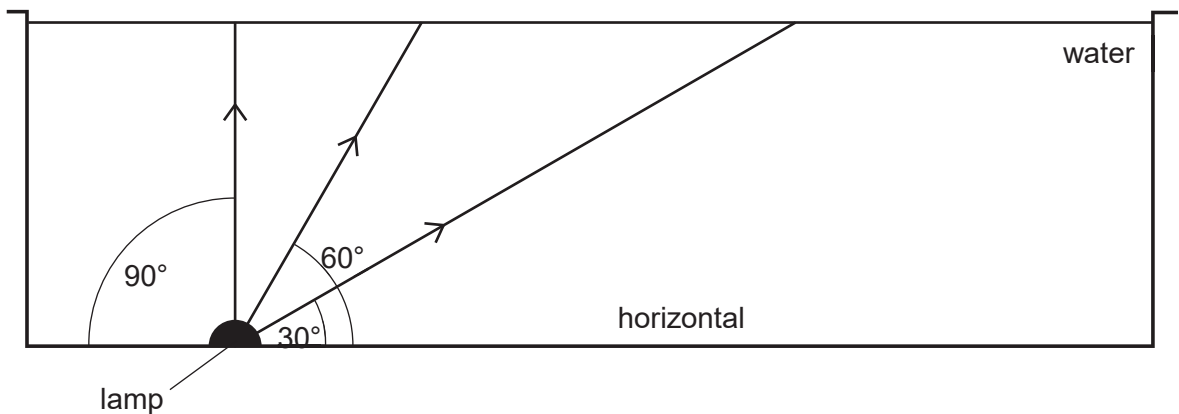

Fig. 4.1

On Fig. 4.1, draw the path taken by each of the three rays after they strike the surface of the water. [2]

- (c) Determine n_{water} , the refractive index of water.

$$n_{water} = \dots\dots\dots[2]$$

- (d) The lamp is moved towards the right. It is observed that, at a certain position, a circular patch of light is seen on the surface of the water.

Explain how this circular patch is formed.

.....
.....
.....[2]

[Total : 7 m]

- 5 Fig. 5.1 shows two glass containers, one painted black and one painted white, containing gases A and B respectively. They are connected together by a tube containing mercury.

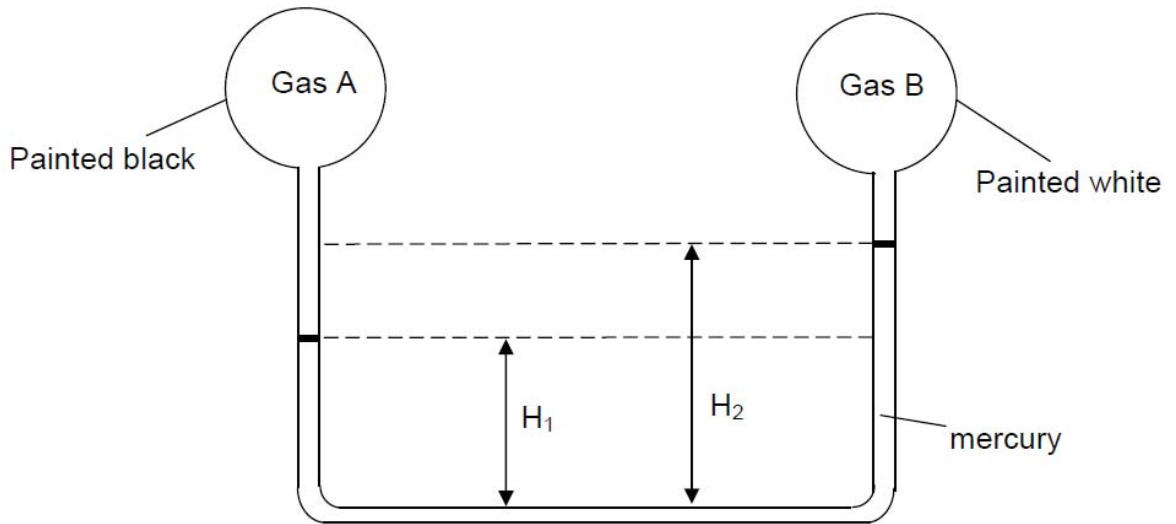

Fig.5.1

The density of mercury density is $13\,600\text{ kgm}^{-3}$.

- (a) State which of the two types of gases is at higher pressure.
[1]

- (b) Given that $H_1 = 40.0\text{ cm}$ and $H_2 = 48.0\text{ cm}$ and Gas A is at $120\,000\text{ Pa}$, calculate the pressure of Gas B.

Pressure=[2]

- (c) The whole set up is then placed under strong sunlight. Describe and explain how H_1 and H_2 would change.

[3]

[Total : 6 m]

6 Fig. 6.1 shows a cylindrical copper kettle that contains cold water.

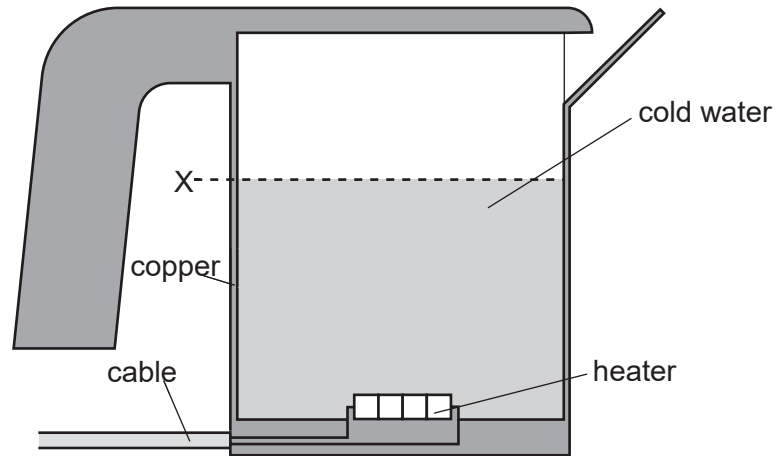

Fig. 6.1

(a) State and explain the advantage of heating the water from below.

.....

 [2]

(b) As the water is heated, it expands.

(i) Explain, in terms of molecules, why water expands when it is heated.

.....

 [2]

(ii) Copper also expands when heated.

State what happens to level X of the water in the kettle. Explain your answer in terms of the expansion of the copper and the water.

.....

 [2]

[Total : 6 m]

7 Fig. 7.1 shows a design for a simple circuit breaker in a household circuit.

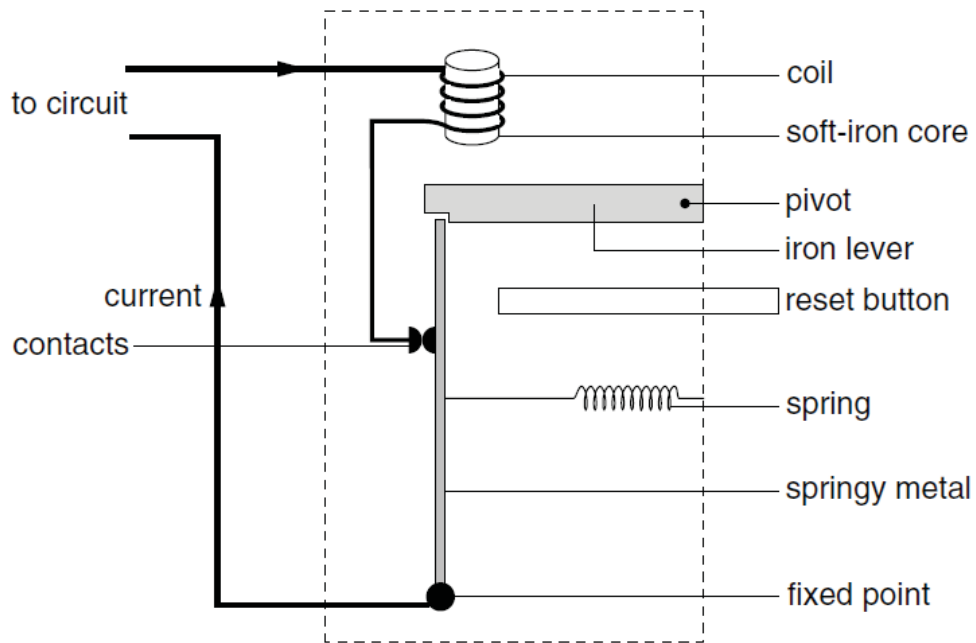

Fig. 7.1

(a) The circuit breaker opens the circuit when the current gets too high. Explain how the circuit breaker works as a safety device in the household circuit.

.....

.....

.....

.....

.....

.....

.....

.....

.....[4]

(b) Explain what will happen if the current direction is reversed.

.....

.....

.....

.....[1]

[Total : 5 m]

- 8 Fig. 8 shows the cut-out section of the handle and cradle of an electric toothbrush. The figure on the right of the cut-out section shows the actual handle and cradle.

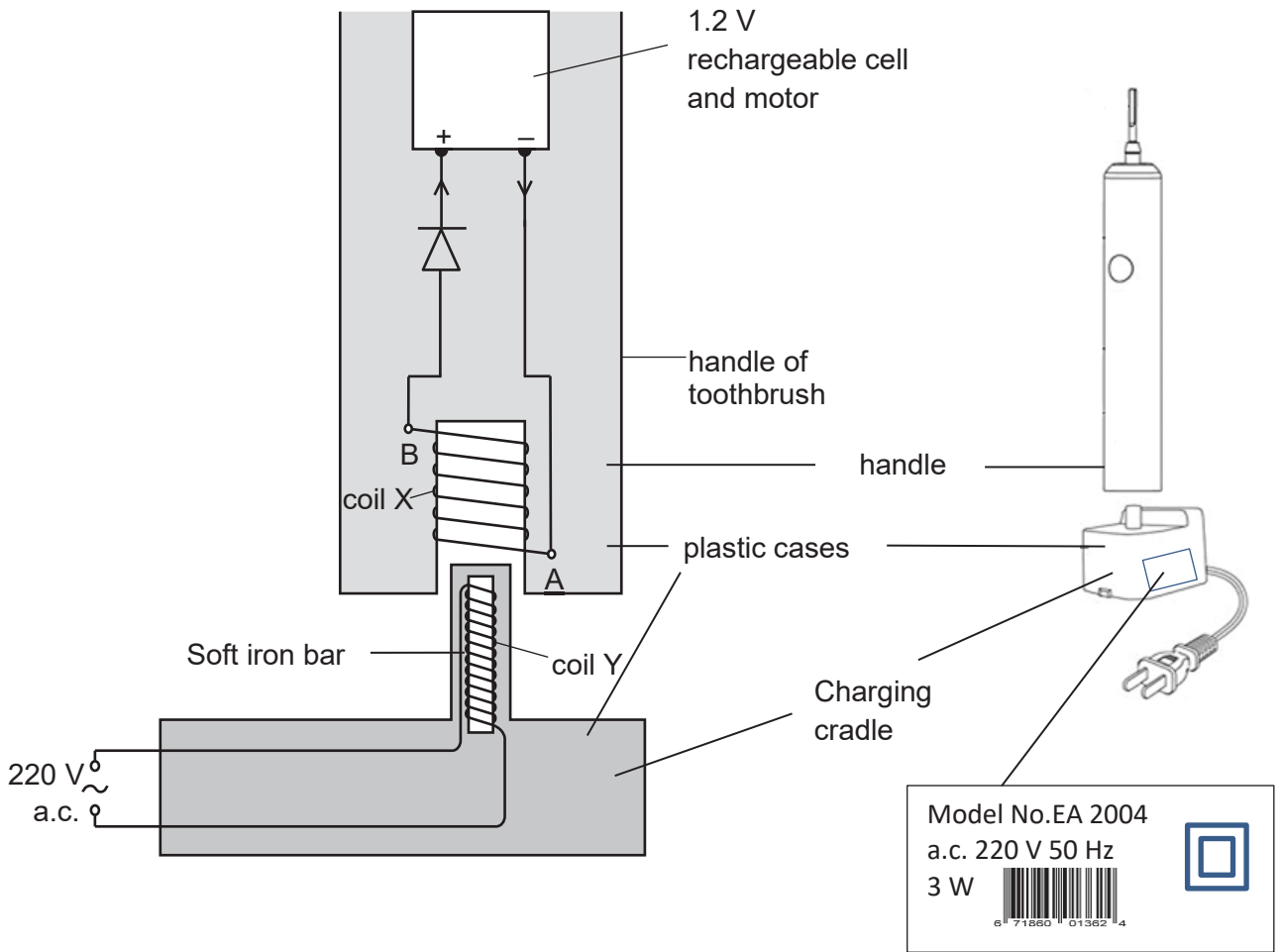

Fig. 8

The handle consists of a 1.2 V rechargeable cell and a motor. The cell is connected to coil X located at the bottom of the unit. The cradle consists of a short projection which houses a coil Y wound round a soft-iron bar. The cradle is connected to a 230 V a.c. mains supply. When the handle is inserted into this short projection, the battery is recharged.

The handle and the charging cradle are completely covered by plastic cases and there is no metal contact between them.

A label is also pasted at the side of the charging cradle.

- (a) When the toothbrush is in operation, the current flowing through the motor is 1.8 A. Calculate the power consumed by the motor.

Power =[1]

- (b) It takes 16 hours to recharge the cell fully. Calculate the amount of energy needed.

Amount of energy =[2]

- (c) Explain how an electromotive force (e.m.f.) is produced in the brush unit to recharge the cell.

.....
.....
.....
.....
.....
.....[3]

- (d) The charging unit is fitted with a two-pin plug.

Suggest one reason why it is safe for the charging unit to be fitted with a two-pin plug.

.....
.....
.....[1]

[Total : 7 m]

END OF SECTION A

SECTION B

Answer **all** the questions in this section.
Answer any one of the two alternative questions in Question 11.

- 9** When a large earthquake occurs at a particular location near the surface of the Earth (known as the Epicentre) three types of seismic waves are produced. These waves are called Primary Waves (P-waves), and Secondary Waves (S-waves) and Surface Waves.

Fig. 9.1 shows the characteristics of these three types of waves.

Primary Waves (P-wave)	Secondary Waves (S-wave)	Surface Waves
<ul style="list-style-type: none"> • Longitudinal waves • Travels through the ground • Fastest waves • Can travel through solid and liquid 	<ul style="list-style-type: none"> • Transverse waves • Travels through the ground • Medium speed waves • Only travel through solids 	<ul style="list-style-type: none"> • Transverse waves • Travels on the surface. • Slowest waves

Fig. 9.1

- (a)** Explain the difference between a longitudinal wave and a transverse wave in terms of particle motion.

.....

.....

.....[1]

- (b) Seismic stations around the Earth detect these seismic waves using an instrument called a seismograph. Two types of seismographs are shown in Fig. 9.2(a) and Fig. 9.2(b).

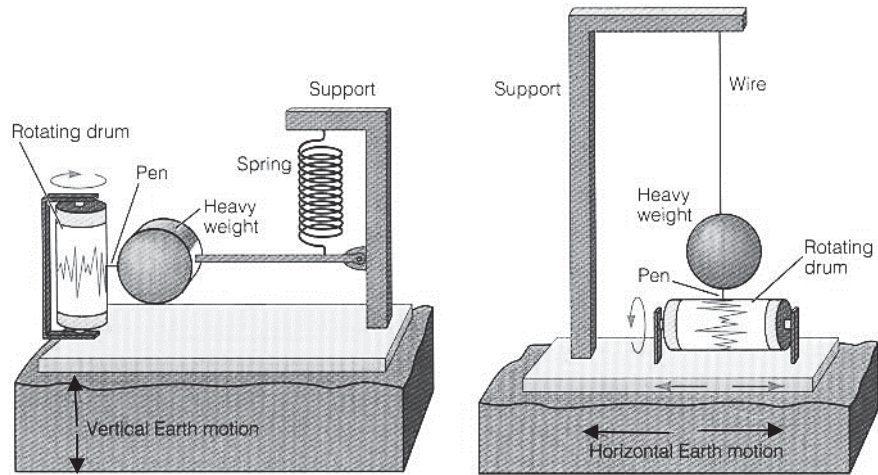

Fig. 9.2(a) Seismograph X

Fig. 9.2(b) Seismograph Y

- (i) Which type of wave does Seismograph X detect?

.....[1]

Fig. 9.3 shows how seismograph X works when an earthquake occurs. The bolts secure the base of the seismometer to the ground. **Fig. 9.3(a)** shows the seismograph before an earthquake occurs.

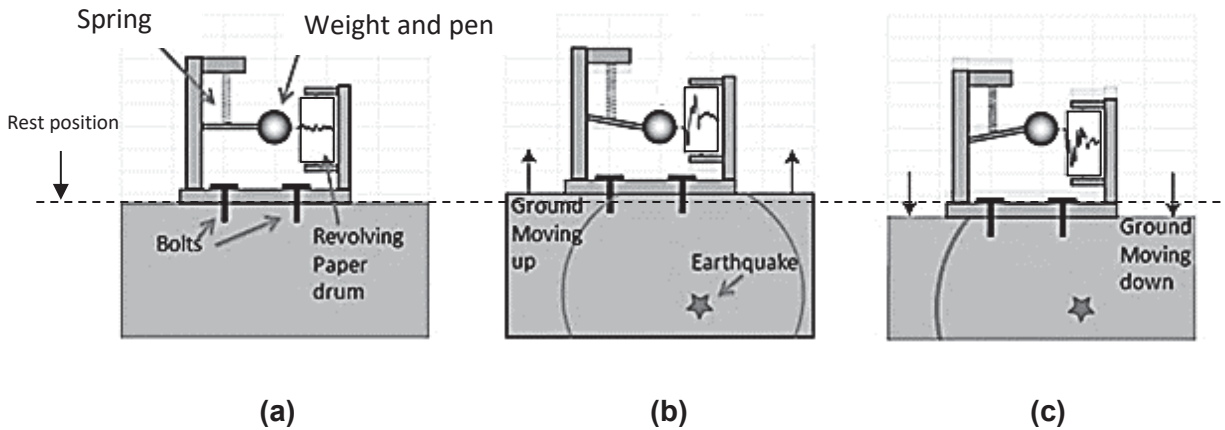

Fig. 9.3

When an earthquake occurs, a seismic wave passes through the ground below the seismograph. The weight moves down when the ground moves up and moves up when the ground moves down. A trace of this motion, known as a seismogram, is recorded on rotating graph paper.

- (ii) Explain how the up-and-down movement of the ground results in the weight moving up and down.

.....

.....

.....

.....

.....

.....

.....[2]

- (c) Fig. 9.4 shows the travel times for a P-wave and a S-wave with distance from the epicentre of an earthquake.

Graph of P-Wave and S-Wave travel time versus distance from epicentre of earthquake

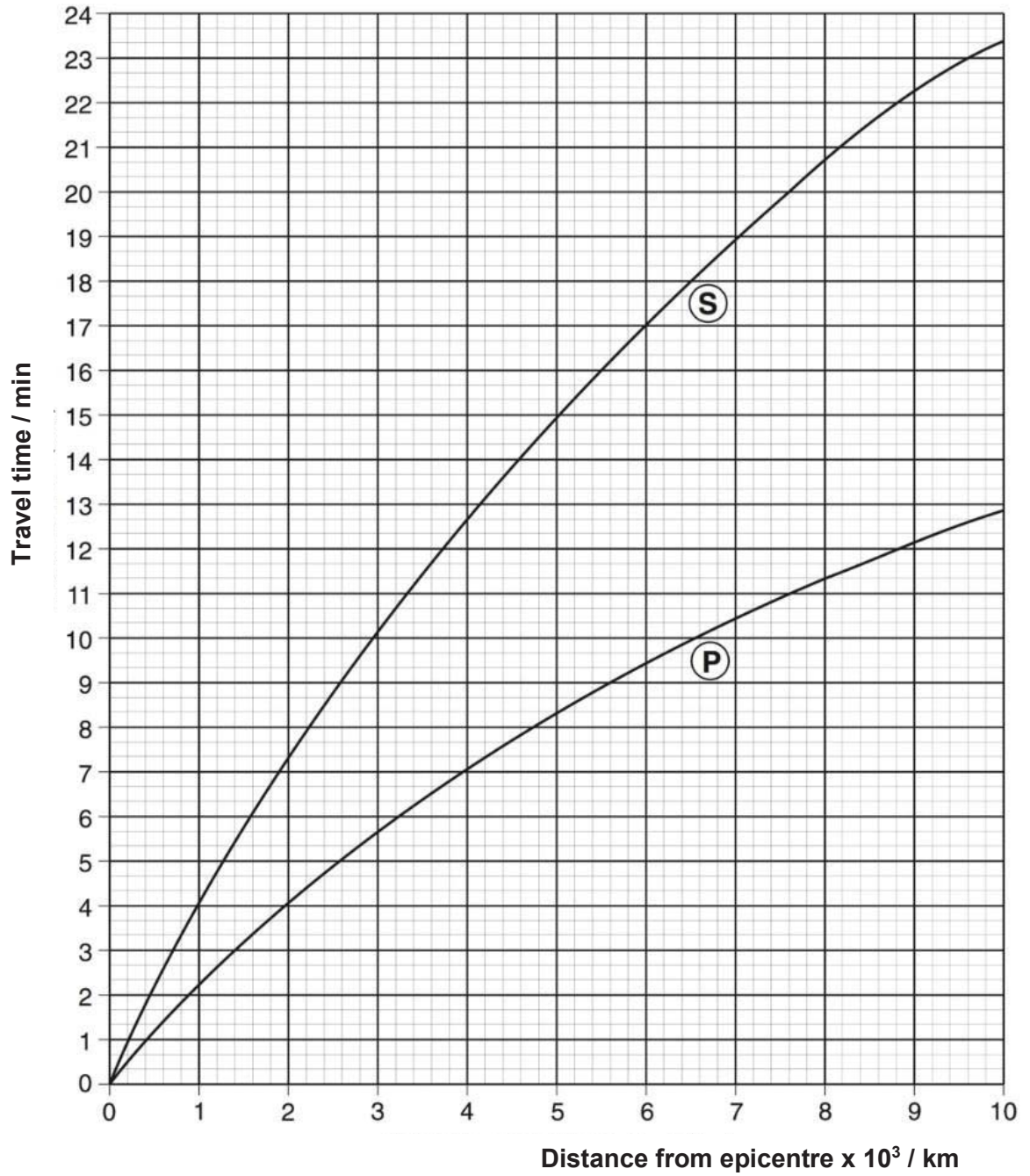

Fig. 9.4

- (i) A seismographic station, A, detects the arrival of an S-wave 5 minutes 40 seconds after the arrival of a P-wave. Using Fig. 9.4, state the distance of the seismographic station from the epicentre of the earthquake. Mark clearly on the graph to show how you arrive at your answer.

Distance =[2]

- (ii) Determine the average speed of the P-waves arriving at Station A in kms^{-1} .

Average speed = [2]

- (iii) Two other seismographic stations, B and C, are located 3.2×10^3 km and 7.8×10^3 km from the epicentre. Determine the average speed of the S-waves in kms^{-1} .

Average speed = [2]

- 10 Fig. 10.1 shows a rotating magnet in an alternating current generator that is used to power a lamp.

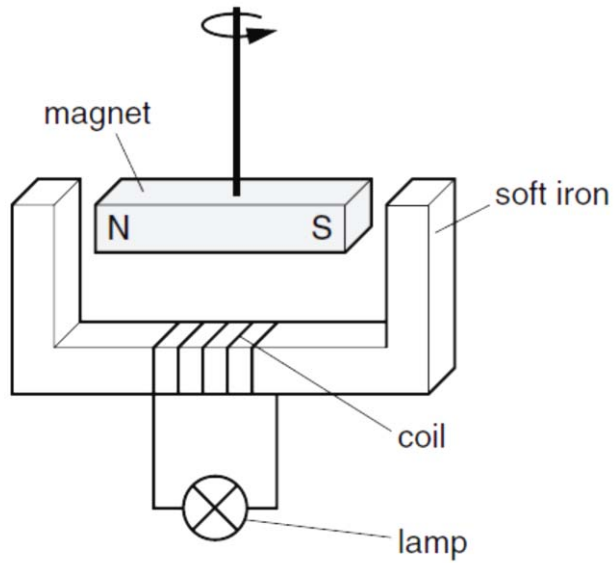

Fig. 10.1

- (a) (i) Explain, in detail, how **alternating** current is produced by the apparatus shown in Fig. 10.1.

.....

.....

.....

.....

.....

.....

.....[3]

- (ii) State two ways in which the current in the lamp may be increased.

1.....

2.....[2]

(b) The generators at a power station produce a voltage of 25 000 V. This voltage is stepped up to 400 000 V by a transformer for long-distance transmission on overhead power lines. The voltage is later stepped down to 240 V.

(i) State and explain why the voltage is stepped up for long-distance transmission.

.....
.....
.....[2]

(ii) Calculate the ratio of the number of turns in the primary coil of the step-up transformer to the number of turns in its secondary coil.

ratio =[1]

(iii) An electric drill of power 800 W is used in a country where the mains voltage is 240 V. State and explain the most appropriate fuse to use with this drill. You should select a fuse from the following values: 1 A, 3 A, 4 A, 13 A.

.....
.....
.....[2]

11 EITHER

11(a) What do you understand by *electrostatic induction* ?

.....
.....
.....[1]

(b) Fig. 11.1 shows two identical light conducting spheres P and Q hanging vertically from two points on insulating threads.

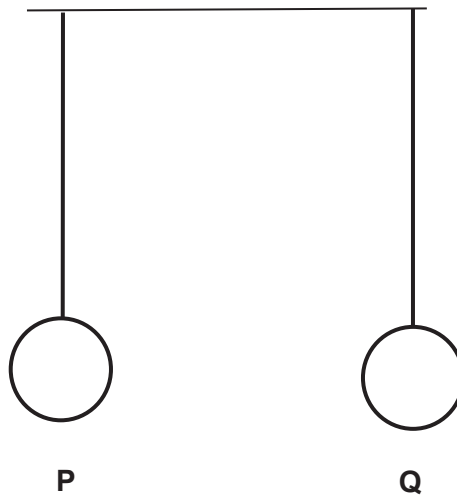

Fig. 11.1

Describe and explain what happens if

(i) P is negatively-charged and Q is neutral,

.....
.....
.....
.....
.....
.....
.....[2]

(ii) both P and Q have the same amount of negative charges.

.....

.....

.....

.....

.....

.....

.....[3]

(c) When a balloon is rubbed on hair, the balloon becomes negatively charged. The balloon is shown in Fig. 11.2.



Fig. 11.2

(i) Explain how rubbing causes the balloon to become negatively charged.

.....

.....

.....

.....

[2]

(ii) Explain why the hair is attracted towards the balloon.

.....
.....
.....[1]

(iii) Explain why it is important that the balloon is made from an electrical insulator.

.....
.....[1]

11 **OR**

Newton's third law of motion can be expressed in the following form.

"When body A exerts a force on body B, then body B exerts a force on body A. These forces are

- equal in magnitude,
- opposite in direction,
- of the same nature.

- (a) An object is undergoing free fall with no air resistance. Explain, using a labelled force diagram, the application of Newton's third law to this falling object.

.....

.....

.....

.....[2]

- (b) An object is dropped out of a plane from 10,000 m. Air resistance increases as the object speeds towards Earth.

- (i) On Fig. 11.1, sketch a graph to show how the speed of the object falling from rest in air varies with time. [1]

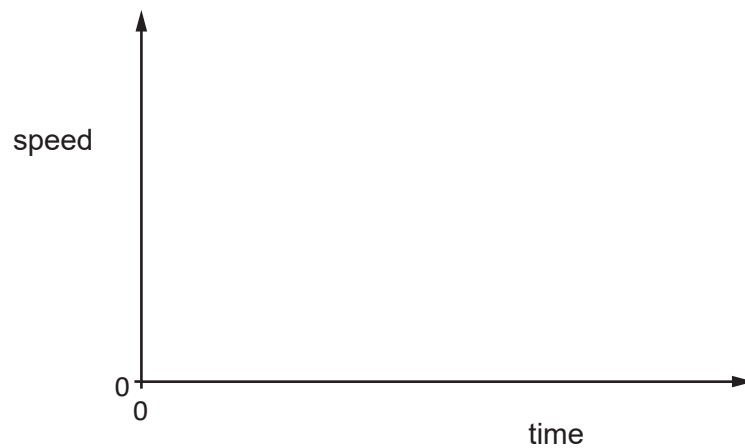

Fig. 11.1

Assume that the centre of gravity (C of G) of the diver remains at the same position within the diver throughout the dive and ignore air resistance.

- (i) Explain what you understand by the centre of gravity (C of G) of an object.

.....
.....[1]

- (ii) Determine the maximum height of his centre of gravity above the water.

height = [2]

- (iii) Determine the speed at which the diver's head reaches the water.

speed = [2]

END OF PAPER

BLANK PAGE

