

Visit

FREETESTPAPER.com

for more papers



Website: [freetestpaper.com](http://www.freetestpaper.com)



[Facebook.com/freetestpaper](https://www.facebook.com/freetestpaper)



[Twitter.com/freetestpaper](https://www.twitter.com/freetestpaper)

Name: _____ ()

Class: _____



CHIJ KATONG CONVENT
MID-YEAR EXAMINATIONS 2018
Secondary Four Express and
Secondary Five Normal (Academic)

SCIENCE (CHEMISTRY, BIOLOGY)

5078/01

Paper 1 Multiple Choice

Duration: 1 hour

Classes: 403, 404, 405, 501 and 502

Additional Materials: Optical Answer Sheets

READ THESE INSTRUCTIONS FIRST

Write in soft pencil.

Write your name, registration number and class on all the work you hand in.

Do not use staples, paper clips, highlighters, glue or correction fluid/ tape.

There are **forty** questions on this paper. Answer **all** questions. For each question there are four possible answers, **A, B, C** and **D**.

Choose the **one** you consider correct and record your choice in **soft pencil** on the separate Optical Answer Sheet.

Complete the Chemistry and Biology sections on two separate Optical Answer Sheets provided.

Read the instructions on the Optical Answer Sheet very carefully.

Each correct answer will score one mark. A mark will not be deducted for a wrong answer. Any rough working should be done in this booklet.

A copy of the Data Sheet is printed on page 16.

A copy of the Periodic Table is printed on page 17.

The use of an approved scientific calculator is expected, where appropriate.

1 Diagrams X, Y and Z represent the three states of matter.

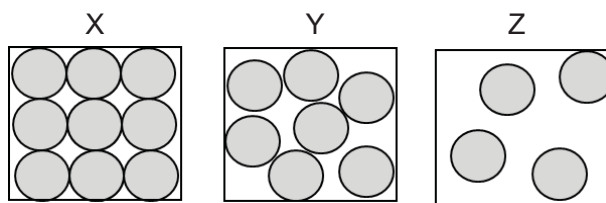

Which change occurs during boiling?

- A X to Y
- B Y to Z
- C Z to X
- D Z to Y

2 P, Q, R and S are pieces of apparatus.

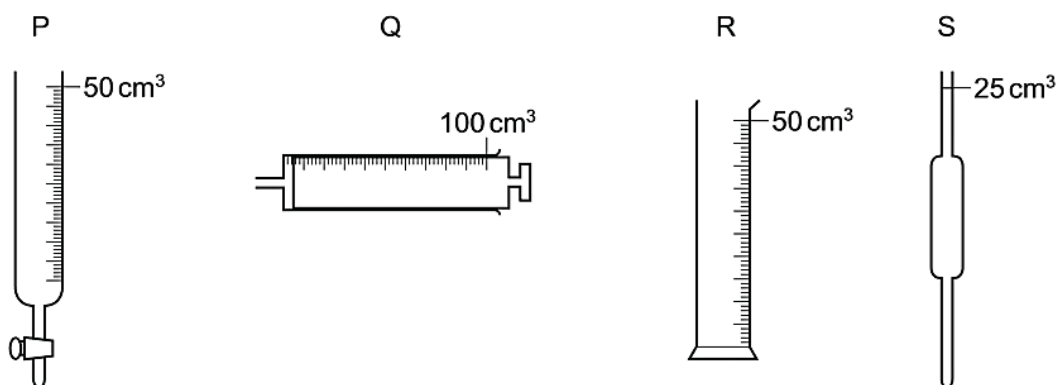

Which row describes the correct apparatus for the measurement made?

	apparatus	measurement made
A	P	15.60 cm ³ of acid to be added to alkali in a titration
B	Q	1 cm ³ of acid to be added to calcium carbonate in an experiment
C	R	75 cm ³ of gas given off in a thermal decomposition reaction
D	S	20.0 cm ³ of alkali to be used in a titration

3 Which method of separation should be used to obtain pure water from copper(II) sulfate solution?

- A crystallisation
- B evaporation to dryness
- C filtration
- D simple distillation

- 4 A food colouring is compared with four different dyes. The chromatogram produced is shown in the diagram.

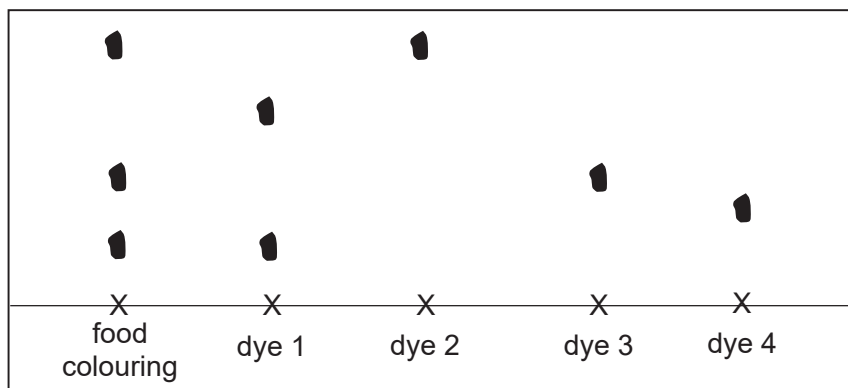

Which dyes does the food colouring contain?

- A 1 and 2 only
 - B 1 and 3 only
 - C 2 and 3 only
 - D 2 and 4 only
- 5 The table shows the boiling points of acetone and water.

substance	boiling point/ °C
acetone	56
water	100

A sample of water was found to contain a small amount of acetone.

What could be the boiling point of the water sample?

- A 56 °C
 - B 78 °C
 - C 100 °C
 - D 104 °C
- 6 Which diagram shows a mixture of two compounds?

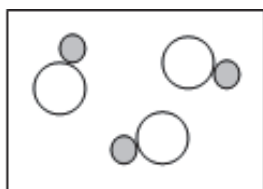

A

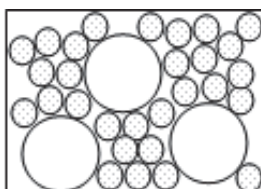

B

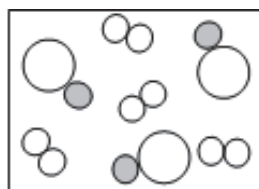

C

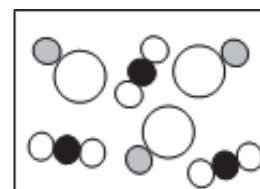

D

- 7 Which statement about an atom is correct?
- A The nucleon number is smaller than the proton number.
 - B The nucleon number is the sum of the number of protons and electrons.
 - C The number of proton always equals the number of electrons.
 - D The number of proton always equals the number of neutrons.

- 8 How many hydrogen atoms are there in 4 moles of ammonia gas?

- A 1.5×10^{23} atoms
- B 1.8×10^{24} atoms
- C 2.4×10^{24} atoms
- D 7.2×10^{24} atoms

- 9 20 cm^3 of carbon monoxide was burnt in 40 cm^3 of oxygen.

The equation of the reaction is shown.

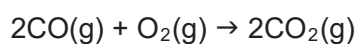

What is the total volume of gas remaining at the end of the reaction?

- A 20 cm^3
 - B 40 cm^3
 - C 60 cm^3
 - D 80 cm^3
- 10 Due to acid rain, the acidity of the soil is increased, making it unsuitable for plant growth.

Which substance is used by farmers to decrease the acidity in the soil?

- A calcium carbonate
- B calcium hydroxide
- C calcium nitrate
- D calcium sulfate

- 11 An unknown oxide was added separately to hydrochloric acid and aqueous sodium hydroxide. The pH of the resulting solution was measured and shown in the table.

chemical	pH of resulting solution
hydrochloric acid	7.0
sodium hydroxide	7.0

What could the unknown oxide be?

- A aluminium oxide
- B carbon monoxide
- C potassium oxide
- D sulfur dioxide

12 The electronic structures of atoms X and Y are shown.

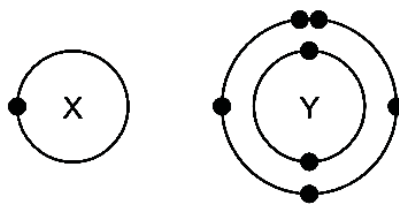

What is the formula of the covalent compound formed between X and Y?

- A XY₅
- B XY₃
- C XY
- D X₃Y

13 The table shows the properties of substances J, K, L and M.

substance	density/ g/dm ³	melting point/ °C	electrical conductivity in solid state
J	2.1	115	poor
K	5.7	232	good
L	6.3	1326	poor
M	19.3	1064	good

Which substances are metals?

- A J and K only
- B J and L only
- C K and M only
- D L and M only

14 The table shows the electronic configuration of four elements, P, Q, R, S.

element	electronic configuration
P	2.2
Q	2.8
R	2.8.2
S	2.8.7

Which statement is correct?

- A P and R are in the same group.
- B Q and R have the same number of electron shells.
- C Q and S are in the same period.
- D R and S have the same number of valence electrons.

15 The table shows the results of some halogen displacement experiments.

halide solution halogen added	X	Y	Z
X		✓	✗
Y	✗		✗
Z	✓	✓	

Key:
 ✓ visible reaction
 ✗ no visible reaction

What row shows the order of halogens in increasing reactivity?

	lowest	—————>	highest
A	X	Y	Z
B	Y	X	Z
C	Y	Z	X
D	Z	X	Y

16 Solid hydrated sodium carbonate was added to aqueous citric acid. The mixture was stirred and the temperature was recorded every 10 seconds. The results are shown on the graph

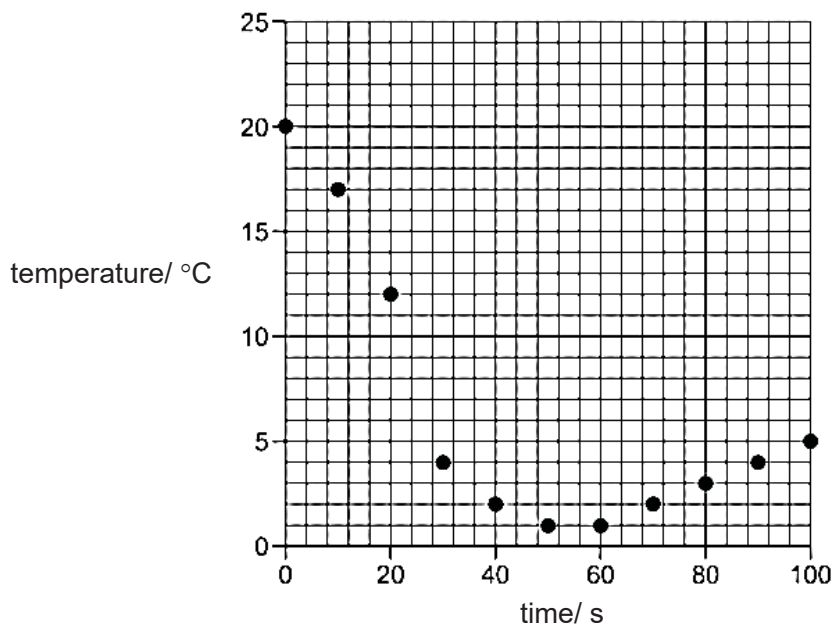

Which row describes the reaction?

	reaction type	energy change
A	neutralisation	endothermic
B	neutralisation	exothermic
C	precipitation	endothermic
D	precipitation	exothermic

17 Which process is endothermic?

- A condensation
- B freezing
- C photosynthesis
- D rusting

18 The effect of temperature on the rate of the reaction between zinc and hydrochloric acid can be investigated by measuring the production of gas.

Which equipment is not required for the investigation?

- A condenser
- B gas syringe
- C stopwatch
- D thermometer

19 The element vanadium, V, forms several oxides.

Which reaction shows oxidation taking place?

- A $\text{VO}_2 \rightarrow \text{V}_2\text{O}_3$
- B $\text{V}_2\text{O}_5 \rightarrow \text{VO}_2$
- C $\text{V}_2\text{O}_3 \rightarrow \text{VO}$
- D $\text{V}_2\text{O}_3 \rightarrow \text{V}_2\text{O}_5$

20 The apparatus shown is set up and left for a week.

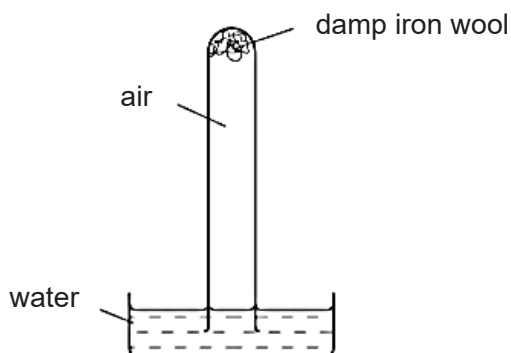

Which diagram best shows the level of the water at the end of the week?

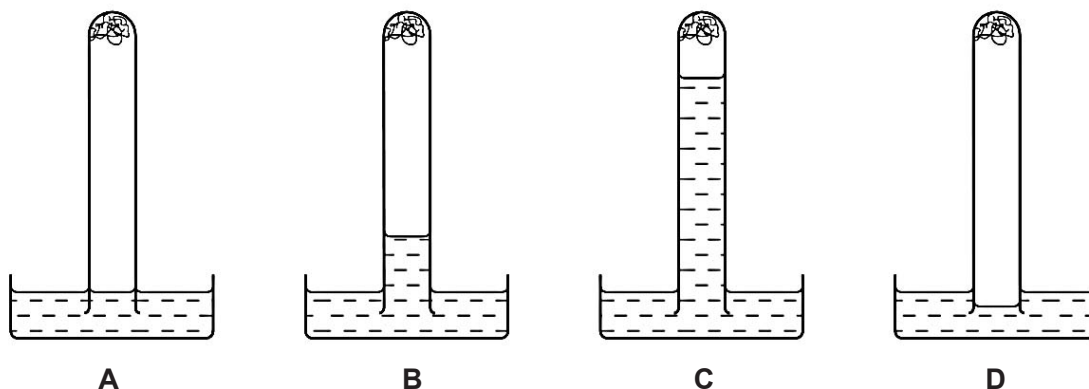

Data Sheet**Colours of Some Common Metal Hydroxides**

calcium hydroxide	white
copper(II) hydroxide	light blue
iron(II) hydroxide	green
iron(III) hydroxide	red-brown
lead(II) hydroxide	white
zinc hydroxide	white

The Periodic Table of Elements

Group																	
I	II											III	IV	V	VI	VII	0
3 Li lithium 7	4 Be beryllium 9											5 B boron 11	6 C carbon 12	7 N nitrogen 14	8 O oxygen 16	9 F fluorine 19	10 Ne neon 20
11 Na sodium 23	12 Mg magnesium 24											13 Al aluminum 27	14 Si silicon 28	15 P phosphorus 31	16 S sulfur 32	17 Cl chlorine 35.5	18 Ar argon 40
19 K potassium 39	20 Ca calcium 40	21 Sc scandium 45	22 Ti titanium 48	23 V vanadium 51	24 Cr chromium 52	25 Mn manganese 55	26 Fe iron 56	27 Co cobalt 59	28 Ni nickel 59	29 Cu copper 64	30 Zn zinc 65	31 Ga gallium 70	32 Ge germanium 73	33 As arsenic 75	34 Se selenium 79	35 Br bromine 80	36 Kr krypton 84
37 Rb rubidium 85	38 Sr strontium 88	39 Y yttrium 89	40 Zr zirconium 91	41 Nb niobium 93	42 Mo molybdenum 96	43 Tc technetium -	44 Ru ruthenium 101	45 Rh rhodium 103	46 Pd palladium 106	47 Ag silver 108	48 Cd cadmium 112	49 In indium 115	50 Sn tin 119	51 Sb antimony 122	52 Te tellurium 128	53 I iodine 127	54 Xe xenon 131
55 Cs caesium 133	56 Ba barium 137	57-71 lanthanoids	72 Hf hafnium 178	73 Ta tantalum 181	74 W tungsten 184	75 Re rhenium 186	76 Os osmium 190	77 Ir iridium 192	78 Pt platinum 195	79 Au gold 197	80 Hg mercury 201	81 Tl thallium 204	82 Pb lead 207	83 Bi bismuth 209	84 Po polonium -	85 At astatine -	86 Rn radon -
87 Fr francium -	88 Ra radium -	89-103 actinoids	104 Rf rutherfordium -	105 Db dubnium -	106 Sg seaborgium -	107 Bh bohrium -	108 Hs hassium -	109 Mt meitnerium -	110 Ds darmstadtium -	111 Rg roentgenium -	112 Cn copernicium -	114 Fl flerovium -	116 Lv livermorium -	118 Og oganeson -	119 Uue unbinilium -	120 Uuo unbinilium -	121 Uuq unbinilium -

Key
 proton (atomic) number
 atomic symbol
 name
 relative atomic mass

1
H
hydrogen
1

lanthanoids	57 La lanthanum 139	58 Ce cerium 140	59 Pr praseodymium 141	60 Nd neodymium 144	61 Pm promethium -	62 Sm samarium 150	63 Eu europium 152	64 Gd gadolinium 157	65 Tb terbium 159	66 Dy dysprosium 163	67 Ho holmium 165	68 Er erbium 167	69 Tm thulium 169	70 Yb ytterbium 173	71 Lu lutetium 175
actinoids	89 Ac actinium -	90 Th thorium 232	91 Pa protactinium 231	92 U uranium 238	93 Np neptunium -	94 Pu plutonium -	95 Am americium -	96 Cm curium -	97 Bk berkelium -	98 Cf californium -	99 Es einsteinium -	100 Fm fermium -	101 Md mendelevium -	102 No nobelium -	103 Lr lawrencium -

The volume of one mole gas is 24 dm³ at room temperature and pressure (r.t.p.).

Name: _____ ()

Class: _____



CHIJ KATONG CONVENT
MID-YEAR EXAMINATIONS 2018
Secondary Four Express and
Secondary Five Normal (Academic)

SCIENCE (CHEMISTRY)

5078/03

Paper 3 Chemistry

Duration: 1 hour 15 minutes

Classes: 403, 404, 405, 501 and 502

Candidates answer on the Question Paper.
No Additional Materials are required.

READ THESE INSTRUCTIONS FIRST

Write your name, class and registration number on all the work you hand in.
Write in dark blue or black pen on both sides of the paper.
You may use a soft pencil for any diagrams or graphs.
Do not use staples, paper clips, highlighters, glue or correction fluid/ tape.

Section A

Answer **all** questions.
Write your answers in the spaces provided on the Question Paper.

Section B

Answer **any two** questions.
Write your answers in the spaces provided on the Question Paper.

A copy of the Data Sheet is printed on page 15.
A copy of the Periodic Table is printed on page 16.

At the end of the examination, hand in:

- (a) Section A;
- (b) Section B separately.

INFORMATION FOR CANDIDATES

The number of marks is given in brackets [] at the end of each question or part question.

FOR EXAMINER'S USE	
Paper 1	/ 20
Paper 3	
Section A	/ 45
Section B	/ 20
TOTAL	/ 85

This question paper consists of **16** printed pages.

[Turn over

Section A [45 marks]

Answer **all** the questions in the spaces provided.

- 1 Substances can be classified as elements, compounds or mixtures. Complete Table 1.1 to describe the following substances.

Table 1.1

substance	classification (element, compound or mixture)	atoms found within the substance
hydrogen sulfide	compound	hydrogen, sulfur
brass		
limestone	compound	

[3]

[Total: 3]

- 2 Iron is the fourth most common element in the Earth's crust and it is also believed to form a large extent of the Earth's core.

- (a) Pure iron can be prepared by the thermal decomposition of iron pentacarbonyl. Fig. 2.1 shows the structure of iron pentacarbonyl.

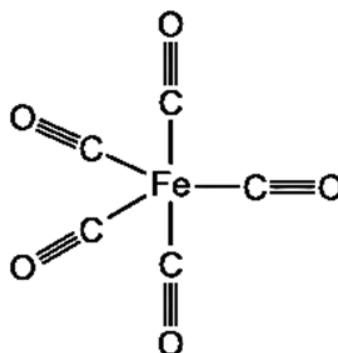

Fig. 2.1

Write the chemical formula for iron pentacarbonyl.

[1]

- (b) (i) Iron metal oxidises partially to form iron(II) oxide.

Predict the electrical conductivity of this compound by including the condition under which conductivity is observed or not at all.

.....

..... [1]

- 2 (b) (ii) Complete Table 2.1 to show the number of electrons, neutrons and protons in iron(II) ion and oxide ion.

Table 2.1

	number of protons	number of neutrons	number of electrons
$^{56}_{26}\text{Fe}^{2+}$	26		
$^{16}_8\text{O}^{2-}$		8	

[2]

- (c) (i) $^{54}_{26}\text{Fe}$ and $^{56}_{26}\text{Fe}$ are two common isotopes of iron.

Define *isotopes*.

.....
 [1]

- (ii) These iron isotopes have different physical properties but exhibit same chemical properties.

Explain this observation.

.....
 [1]

[Total: 6]

- 3 When a colourless solution of copper(I) chloride is left in a beaker for a period of time, the following reaction takes place.



- (a) Calculate the oxidation state of copper in CuCl and CuCl₂.

oxidation state of copper in CuCl
 oxidation state of copper in CuCl₂ [2]

- (b) Explain, in terms of change in oxidation states, why CuCl is both oxidised and reduced in this reaction.

.....
 [2]

3 (c) Describe one observation in this reaction.

.....
 [1]

[Total: 5]

4 (a) Name the pieces of apparatus most suitable to complete the following laboratory procedures:

(i) separate a precipitate from a solution,
[1]

(ii) measure exactly 25.30 cm³ of solution into a conical flask,
[1]

(iii) measuring the mass gained in a reaction,
[1]

(iv) bubbling gas into a test-tube containing solution.
[1]

(b) Chromatography can be used to separate the coloured pigments extracted from lavender flowers. The apparatus used is shown Fig. 4.1.

After a few minutes, the solvent vapour fills the whole chromatography jar.

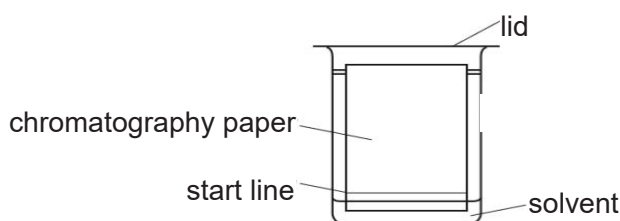

Fig. 4.1

Describe what happens to the movement and arrangement of the solvent particles as they become a vapour.

.....

 [2]

[Total: 6]

5 A solution of nitric acid is prepared by diluting 0.15 mol to make 100 cm³ of solution.

(a) Calculate the concentration of this solution in mol/dm³ and g/dm³.

concentration = mol/dm³ [1]

concentration = g/dm³ [1]

(b) The chemical equation for the reaction between nitric acid and potassium carbonate is as follows:



100 cm³ of 0.5 mol/dm³ nitric acid is added to an aqueous solution containing 0.02 mol of potassium carbonate.

(i) Calculate the number of moles of nitric acid.

number of moles = [1]

(ii) State the limiting reactant in this reaction.

.....[1]

(iii) Calculate the number of moles of potassium nitrate formed.

number of moles = [1]

[Total: 5]

6 Fig. 6.1 describes some of the properties and reactions of several substances.

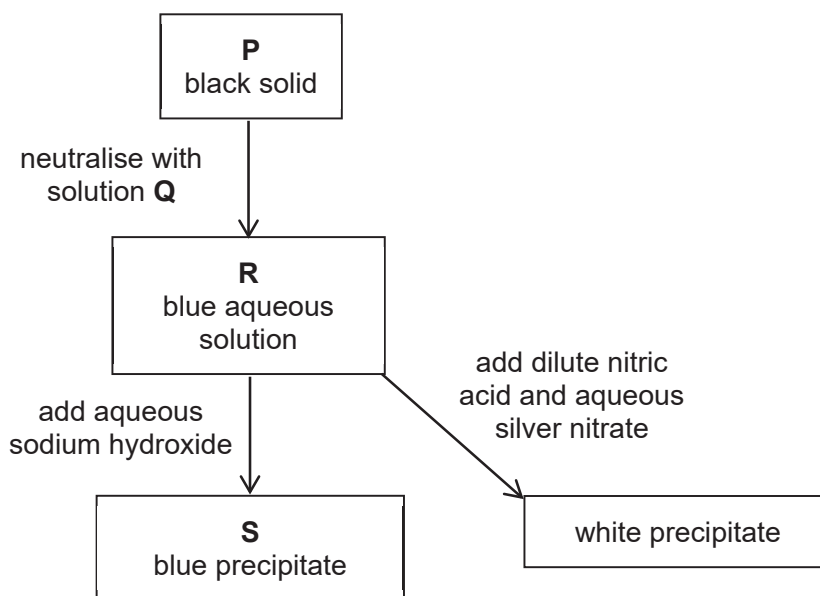

Fig. 6.1

(a) Identify P, Q, R and S.

P

Q

R

S

[4]

(b) Write the ionic equation for the reaction of R with aqueous silver nitrate.

..... [1]

[Total: 5]

- 7 (a) Lithium, sodium and potassium belong to Group I of the Periodic Table. Table 7.1 shows the observations when these three metals react with water.

Table 7.1

Group I metal	observation
lithium	reacts quickly
sodium	reacts violently
potassium	reacts very violently

- (i) Describe and explain the reactivity of Group I metals down the group.
-
-
-
-
-[3]

- (ii) Rubidium is located below potassium in Group I.
- Predict what would happen when rubidium reacts with water.
-
-[1]

- (iii) Name the gas evolved when Group I metals react with water.
-[1]

- (b) Group 0 elements are also known as noble gases.

- (i) State one physical property of noble gases.
-
-[1]

- (ii) Using your knowledge of electronic structures, explain why elements in Group 0 are unreactive.
-
-
-[1]

[Total: 7]

- 8 The petrol burnt in car engines react with air to form a mixture of gases.
 Table 8.1 shows the composition of the mixture of all the gases coming from car exhaust fumes.

Table 8.1

gas	% of gas in the exhaust fumes
carbon dioxide	15
carbon monoxide	3
hydrocarbons	2
hydrogen	1
oxides of nitrogen	1
oxygen	1
water vapour	18
gas W	59

(a) Identify gas **W**. [1]

(b) The amount of carbon dioxide emitted by vehicles contributes to the increasing concentration of the gas in the atmosphere.

Explain why this is a global concern.

.....

[2]

(c) Explain why carbon monoxide is found in the exhaust gases.

.....
[1]

- 8 (d) Water is one of the major by-products in the combustion of petrol in vehicles.

Draw a 'dot and cross' diagram of water, showing only the arrangement of electrons on the valence shells.

- (e) The combustion of petrol is exothermic.

[2]

- (i) Define *exothermic*.

..... [1]

- (ii) Give another example of an exothermic reaction.

..... [1]

[Total: 8]

Name: _____ ()

Class: _____

Section B [20 marks]

Answer any **two** questions in this section.
Write your answers in the spaces provided.

9 Magnesium sulfate is formed from the reaction between a metal, M and an acid, N.

(a) Name M and N.

M

N

[2]

(b) Write the balanced chemical equation for the reaction between M and N.

..... [1]

(c) Describe how pure crystals of magnesium sulfate can be prepared using metal M and acid N.

.....

 [4]

(d) Magnesium sulfate can also be prepared using acid N and another substance.

Name this substance.

..... [1]

9 (e) The labels on two bottles, one containing acid N and the other containing aqueous ammonia, were missing.

(i) Briefly describe a method you would use to distinguish between the two solutions.

.....
 [1]

(ii) State the result you would expect for acid N using the method described in **(e)(i)**.

.....
 [1]

[Total: 10]

10 Iron is a metal that is commonly used in the construction of ships and bridges.

(a) Iron is extracted from haematite using carbon in a blast furnace. Impurities from the iron are removed using limestone.

Describe how limestone is used to remove impurities from iron and include suitable chemical equations in your answer.

.....

 [4]

(b) When iron is exposed to the environment for some time, it starts to rust.

(i) Bridges made of iron are painted to prevent rusting.

Explain how the layer of paint prevents iron from rusting.

.....
 [1]

10 (b) (ii) Some ships that are made of iron prevent rusting by attaching blocks of zinc to its surface. After some time, it was observed the block of zinc corroded instead of iron.

Explain how attaching blocks of zinc help to prevent the ship from rusting.

.....
 [1]

(iii) Predict what happens when blocks of silver metal are attached to the iron surface of the ship instead of zinc.

..... [1]

(iv) It was observed that ships in the sea tend to corrode more quickly than bridges.

Suggest a reason to explain this phenomenon.

.....
 [1]

(c) In addition to the production of iron using the blast furnace, iron is also obtained through recycling.

Give two reasons why it is important to recycle metal.

1.....

 2.....
 [2]

[Total: 10]

11 Egg shells are made up mainly of calcium carbonate. A pupil carried out an experiment to react egg shells with excess dilute hydrochloric acid. The gas that was produced was measured at a regular time interval to investigate the speed of the reaction.

(a) Predict the solubility of this gas in water.

..... [1]

(b) Complete the diagram in Fig. 11.1 to show the apparatus which could be used to measure the volume of gas produced.

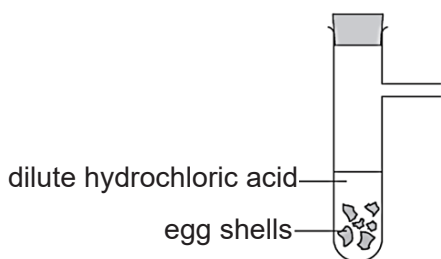

Fig. 11.1 [2]

(c) The results of this experiment are shown in Table 11.1.

Table 11.1

time/ s	0	20	40	60	140	180	200	220
volume of gas/ cm ³	0	14	25	32	48	50	50	50

(i) Plot the results on Fig. 11.2 and draw a smooth curve through the points.

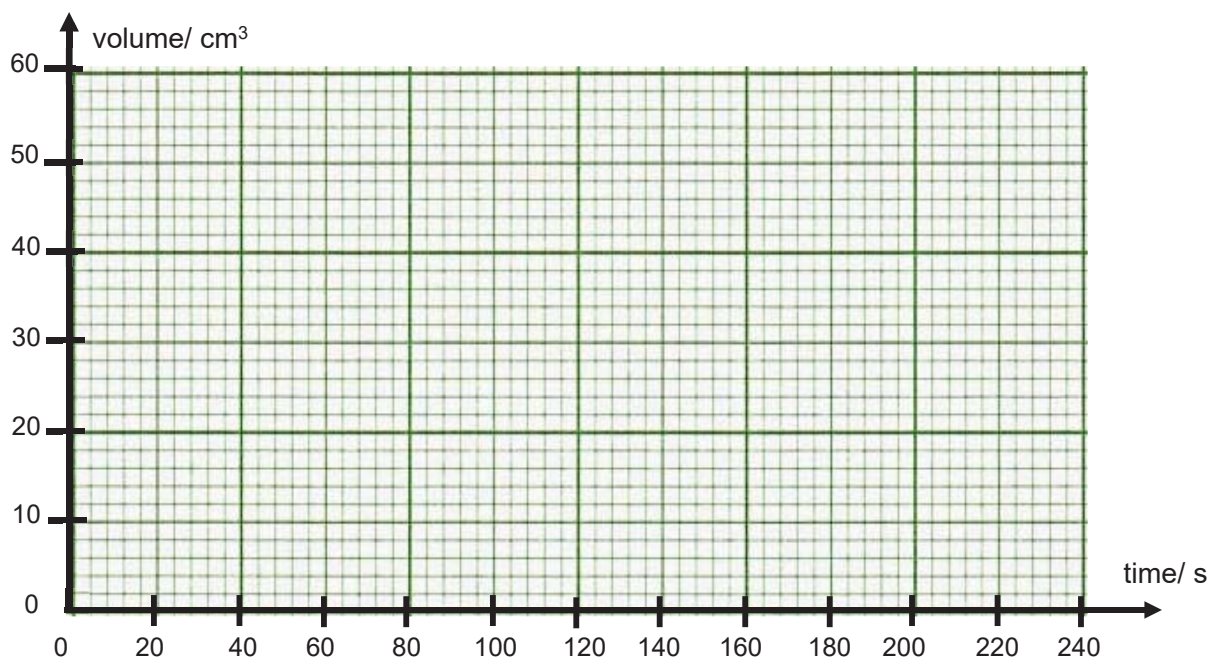

Fig 11.2 [2]

11 (c) (ii) Explain why no further measurements were taken after 220 seconds.

.....
 [1]

(iii) Using the graph drawn in **(c)(i)**, estimate the volume of gas evolved for the first 100 seconds.

..... [1]

(iv) Calculate the average speed of reaction in cm³/s for the first 10 seconds of the reaction.

(Average speed = $\frac{\text{final volume} - \text{initial volume}}{\text{duration concerned}}$)

..... cm³/s [2]

(v) The experiment is repeated with crushed egg shell.
 On the same axes in Fig. 11.2, draw the graph you would expect for the second experiment.
 Labelled the graph as 'Q'. [1]

[Total: 10]

Data Sheet**Colours of Some Common Metal Hydroxides**

calcium hydroxide	white
copper(II) hydroxide	light blue
iron(II) hydroxide	green
iron(III) hydroxide	red-brown
lead(II) hydroxide	white
zinc hydroxide	white

The Periodic Table of Elements

		Group																																			
I	II	III	IV	V	VI	VII	0																														
3 Li lithium 7	4 Be beryllium 9	11 Na sodium 23	12 Mg magnesium 24	19 K potassium 39	20 Ca calcium 40	21 Sc scandium 45	22 Ti titanium 48	23 V vanadium 51	24 Cr chromium 52	25 Mn manganese 55	26 Fe iron 56	27 Co cobalt 59	28 Ni nickel 59	29 Cu copper 64	30 Zn zinc 65	31 Ga gallium 70	32 Ge germanium 73	33 As arsenic 75	34 Se selenium 79	35 Br bromine 80	36 Kr krypton 84	54 Xe xenon 131															
7 N nitrogen 14	8 O oxygen 16	13 Al aluminium 27	14 Si silicon 28	15 P phosphorus 31	16 S sulphur 32	17 Cl chlorine 35.5	18 Ar argon 40	5 B boron 11	6 C carbon 12	7 N nitrogen 14	8 O oxygen 16	9 F fluorine 19	10 Ne neon 20	13 Al aluminium 27	14 Si silicon 28	15 P phosphorus 31	16 S sulphur 32	17 Cl chlorine 35.5	18 Ar argon 40	5 B boron 11	6 C carbon 12	7 N nitrogen 14	8 O oxygen 16	9 F fluorine 19	10 Ne neon 20												
37 Rb rubidium 85	38 Sr strontium 88	39 Y yttrium 89	57-71 lanthanoids	56 Ba barium 137	87 Fr francium 133	88 Ra radium 137	89-103 actinoids	89 Ac actinium 227	90 Th thorium 232	91 Pa protactinium 231	92 U uranium 238	93 Np neptunium 237	94 Pu plutonium 244	95 Am americium 243	96 Cm curium 247	97 Bk berkelium 247	98 Cf californium 251	99 Es einsteinium 252	100 Fm fermium 257	101 Md mendelevium 258	102 No nobelium 259	103 Lr lawrencium 262	104 Rf rutherfordium 261	105 Db dubnium 262	106 Sg seaborgium 263	107 Bh bohrium 264	108 Hs hassium 265	109 Mt meitnerium 266	110 Ds darmstadtium 271	111 Rg roentgenium 272	112 Cn copernicium 285	113 Nh nihonium 286	114 Fl flerovium 289	115 Mc moscovium 288	116 Lv livermorium 293	117 Ts tennessine 294	118 Og oganesson 294

Key
proton (atomic) number
atomic symbol
name
relative atomic mass

lanthanoids	57 La lanthanum 139	58 Ce cerium 140	59 Pr praseodymium 141	60 Nd neodymium 144	61 Pm promethium 145	62 Sm samarium 150	63 Eu europium 152	64 Gd gadolinium 157	65 Tb terbium 159	66 Dy dysprosium 163	67 Ho holmium 165	68 Er erbium 167	69 Tm thulium 169	70 Yb ytterbium 173	71 Lu lutetium 175
actinoids	89 Ac actinium	90 Th thorium	91 Pa protactinium	92 U uranium	93 Np neptunium	94 Pu plutonium	95 Am americium	96 Cm curium	97 Bk berkelium	98 Cf californium	99 Es einsteinium	100 Fm fermium	101 Md mendelevium	102 No nobelium	103 Lr lawrencium

The volume of one mole of any gas is 24 dm³ at room temperature and pressure (r.t.p.).

Answer scheme

Paper 1

1	2	3	4	5	6	7	8	9	10
B	A	D	C	D	D	C	D	C	B
11	12	13	14	15	16	17	18	19	20
A	D	C	A	B	A	C	A	D	B

Paper 3

Section A

Qn	Answers												
1	<table border="1"> <thead> <tr> <th>substance</th> <th>classification (element, compound or mixture)</th> <th>atoms found within the substance</th> </tr> </thead> <tbody> <tr> <td>hydrogen sulfide</td> <td>compound</td> <td>hydrogen, sulfur</td> </tr> <tr> <td>brass</td> <td>mixture</td> <td>copper, zinc</td> </tr> <tr> <td>limestone</td> <td>compound</td> <td>calcium, carbon, oxygen</td> </tr> </tbody> </table>	substance	classification (element, compound or mixture)	atoms found within the substance	hydrogen sulfide	compound	hydrogen, sulfur	brass	mixture	copper, zinc	limestone	compound	calcium, carbon, oxygen
substance	classification (element, compound or mixture)	atoms found within the substance											
hydrogen sulfide	compound	hydrogen, sulfur											
brass	mixture	copper, zinc											
limestone	compound	calcium, carbon, oxygen											
2a	$\text{Fe}(\text{CO})_5$												
2b(i)	Iron(II) oxide conducts electricity only in molten form. OR Iron(II) oxide does not conduct electricity as a solid.												
2b(ii)	<table border="1"> <thead> <tr> <th></th> <th>number of protons</th> <th>number of neutrons</th> <th>number of electrons</th> </tr> </thead> <tbody> <tr> <td>${}^{56}_{26}\text{Fe}^{2+}$</td> <td>26</td> <td>30</td> <td>24</td> </tr> <tr> <td>${}^{16}_8\text{O}^{2-}$</td> <td>8</td> <td>8</td> <td>10</td> </tr> </tbody> </table>		number of protons	number of neutrons	number of electrons	${}^{56}_{26}\text{Fe}^{2+}$	26	30	24	${}^{16}_8\text{O}^{2-}$	8	8	10
	number of protons	number of neutrons	number of electrons										
${}^{56}_{26}\text{Fe}^{2+}$	26	30	24										
${}^{16}_8\text{O}^{2-}$	8	8	10										
2c(i)	Isotopes are <u>atoms of the same element</u> with the <u>same number of protons</u> but <u>different number of neutrons</u> .												
2c(ii)	As the isotopes have <u>the same number of valence electrons</u> , they possess the same chemical properties.												
3a	oxidation state of copper in CuCl = +1 oxidation state of copper in CuCl_2 = +2												
3b	CuCl is oxidised to CuCl_2 as the oxidation state of Cu increases from +1 in CuCl to +2 in CuCl_2 . CuCl is reduced to Cu as the oxidation state of Cu decreases from +1 in CuCl to 0 in Cu.												

3c	The colourless solution turns blue OR A pink/ brown/ reddish-brown solid is formed.
4a(i)	filter funnel
4a(ii)	burette
4a(iii)	electronic balance
4a(iv)	delivery tube/ teat pipette
4b	When the solvent particles become a vapour, they are moving at <u>high speeds</u> in <u>all directions</u> and spaced <u>far</u> apart.
5a	Concentration of HNO ₃ in mol/dm ³ = $0.15 \div \frac{100}{1000} = \underline{1.5 \text{ mol/dm}^3}$ Concentration of HNO ₃ in g/dm ³ = $1.5 \times 63 = \underline{94.5 \text{ g/dm}^3}$
5bi	Number of moles of HNO ₃ = $\frac{100}{1000} \times 0.5 = \underline{0.05 \text{ mol}}$
5bii	Potassium carbonate / K ₂ CO ₃
5biii	<u>Mole ratio</u> K ₂ CO ₃ : KNO ₃ = 1 : 2 Number of moles of KNO ₃ = $0.02 \times 2 = 0.04 \text{ mol}$
6a	P: copper(II) oxide / CuO Q: hydrochloric acid / HCl R: copper(II) chloride / CuCl ₂ S: copper(II) hydroxide / Cu(OH) ₂
6b	$\text{Ag}^+ (\text{aq}) + \text{Cl}^- (\text{aq}) \rightarrow \text{AgCl} (\text{s})$
7ai	The reactivity of Group I metals increases down the group. Down the group, there are <u>more filled electron shells</u> between the nucleus and the valence electron. Hence, there is a <u>greater tendency to lose the valence electron</u> to attain the noble gas electronic configuration.
7aii	It reacts explosively.
7aiii	Hydrogen gas
7bi	Noble gases are/ have <ul style="list-style-type: none"> • colourless • odourless • gases at room temperature and pressure OR have low melting and boiling points • insoluble in water • poor conductors of electricity • low densities (any one)

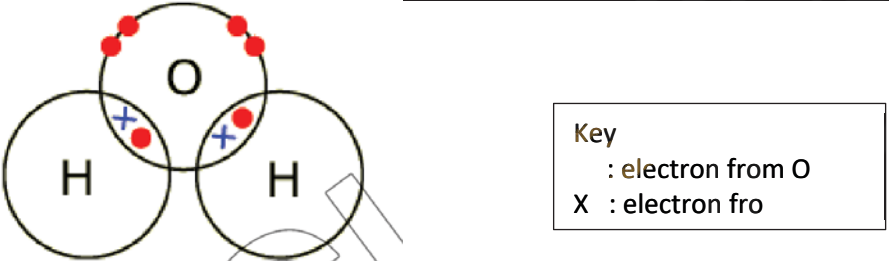
7bii	They have <u>fully-filled valence electron shells</u> and already achieved a stable noble gas electronic configuration.
8a	nitrogen/ N ₂
8b	Carbon dioxide is a greenhouse gas / causes climate change / causes global warming. This results in ice caps melting (or rise in sea levels) / increased flooding / desertification / increased death of corals.
8c	It is formed due to incomplete combustion.
8d	
8ei	A reaction/ a change in which heat is given out to the surroundings.
8eii	Rusting, respiration, neutralisation or any acceptable answer.

Section B

Qn	Answers
9a	M: magnesium N: sulfuric acid
9b	$\text{Mg} + \text{H}_2\text{SO}_4 \rightarrow \text{MgSO}_4 + \text{H}_2$
9c	Steps for making crystals: 1. Add <u>excess</u> magnesium metal to a test tube containing sulfuric acid and stir. 2. <u>Filter</u> to obtain the filtrate, which is magnesium sulfate solution, and remove the excess magnesium metal residue. 3. <u>Heat</u> the filtrate till it is <u>saturated</u> . 4. Allow the saturated solution to <u>cool</u> so that the salt can crystallise. 5. Filter to collect the crystals. Wash the crystals with a little cold distilled water to remove impurities and dry between sheets of filter paper.
9d	Magnesium oxide / magnesium carbonate/ magnesium hydroxide
9ei	Add a few drops of universal indicator solution into each solution. OR Dip a piece of red and blue litmus paper into each solution.
9eii	The solution will turn from green to red. OR The red litmus paper will remain red and the blue litmus paper will turn red.
10a	Limestone is first <u>decomposed by heat</u> to produce carbon dioxide and calcium oxide. $\text{CaCO}_3 (\text{s}) \rightarrow \text{CaO} (\text{s}) + \text{CO}_2 (\text{g})$

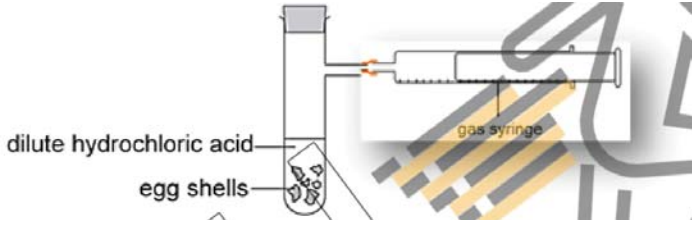
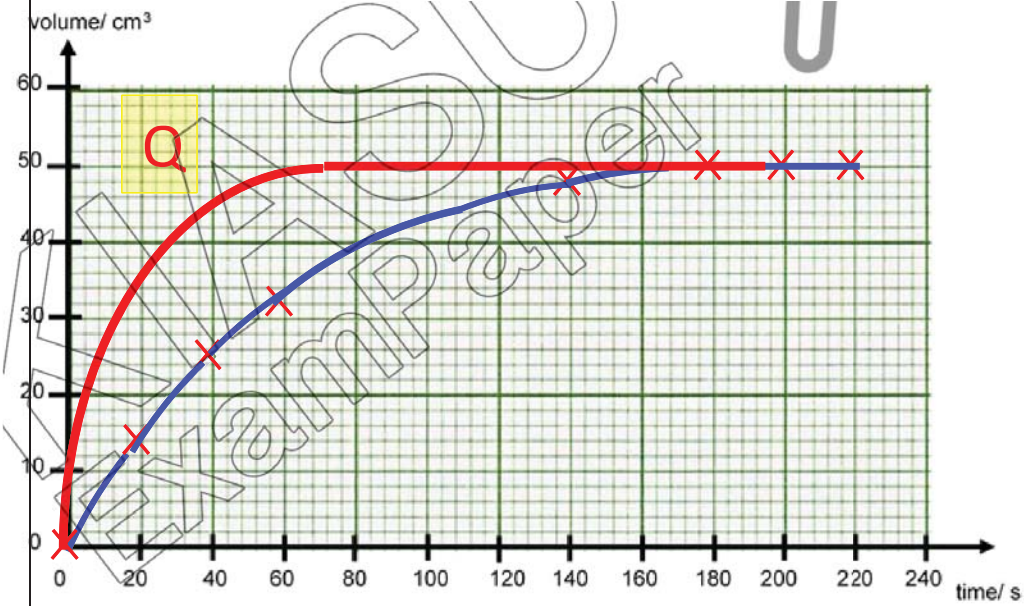
	<p>Calcium oxide reacts with the impurities from iron, which is sand, to form <u>molten slag</u>.</p> $\text{CaO (s)} + \text{SiO}_2 \text{ (s)} \rightarrow \text{CaSiO}_3 \text{ (l)}$
10bi	Paint serves as a protective layer that prevents iron from coming into contact with <u>water and oxygen</u> .
10bii	Zinc is more reactive than iron, hence zinc will react with water and oxygen first.
10biii	The ship will rust.
10biv	The presence of sodium chloride in seawater results in the increase of the speed of rusting.
10c	<ul style="list-style-type: none"> ✓ Recycling helps to conserve finite/ non-renewable metal ores. ✓ Recycling helps to save energy, hence less fossil fuels are burnt for energy production. ✓ Recycling helps to save cost of extracting metals. ✓ Recycling reduces pollution as recycling metals creates less pollutants than extracting metals from its ores. ✓ Recycling reduces the need of landfills for metal extraction wastes <p>(any two)</p>
11a	The gas (carbon dioxide) is slightly soluble/ insoluble in water,
11b	<p>a labelled gas syringe</p> 
11c(i)	
11c(ii)	All the egg shell (calcium carbonate) had been used up.
11c(iii)	Based on students' graph, Acceptable range of 41 – 43 cm ³

11c(iv)	Based on students' graph average speed = $\frac{\text{volume at 10 sec} - \text{volume at 0 sec}}{10 \text{ sec}}$
11c(v)	a graph with a higher gradient but same final volume

