

*Visit*

**FREETESTPAPER.com**

*for more papers*



Website: [freetestpaper.com](http://www.freetestpaper.com)



[Facebook.com/freetestpaper](https://www.facebook.com/freetestpaper)



[Twitter.com/freetestpaper](https://www.twitter.com/freetestpaper)



# Pasir Ris Secondary School

Name	Class	Register Number
------	-------	-----------------

SECONDARY 4 EXPRESS  
MID-YEAR EXAMINATION 2018

SCIENCE (CHEMISTRY)

5076

**May 2018**

1 hour

## READ THESE INSTRUCTIONS FIRST

Write your name, class and register number on all the work you hand in.

Write in dark blue or black pen.

You may use a soft pencil for any diagrams, graphs, tables or rough working.

Do not use staples, paper clips, glue or correction fluid.

### Section A

There are **ten** questions in this section. Answer **all** questions.

For each question there are four possible answers, **A, B, C** and **D**.

Choose the **one** you consider correct and record your choice in the boxes provided on **page 4**.

### Section B & C

Answer **all** questions in the spaces provided.

The number of marks is given in brackets [ ] at the end of each question or part question.

A copy of the Periodic Table is printed on page 8.

Section	Marks
<b>A</b>	<b>/10</b>
<b>B</b>	<b>/20</b>
<b>C</b>	<b>/10</b>
<b>Total</b>	<b>/40</b>

**This document consists of 9 printed pages (inclusive of this page).**

Setter: Mr Mohd Riffai

**[Turn over**

**Section A: Multiple Choice Questions [20 marks]**

- 21 A mixture contains an organic liquid **J**, and a dilute solution of potassium chloride. Liquid **J** boils at 21 °C and is immiscible in water.

Which two methods of separation should be used in sequence to obtain samples of liquid **J** first before solid potassium chloride?

	method 1	method 2
<b>A</b>	use a separating funnel	evaporation
<b>B</b>	evaporation	sublimation
<b>C</b>	distillation	filtration
<b>D</b>	filtration	evaporation

- 22 Which diagram represents a mixture of diatomic elements?

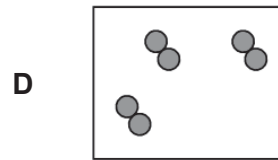
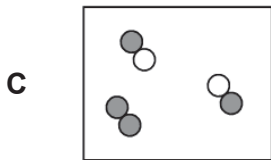
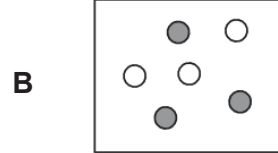
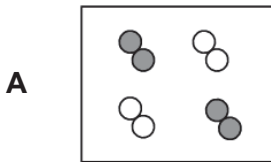

- 23 The diagrams represent four different compounds.

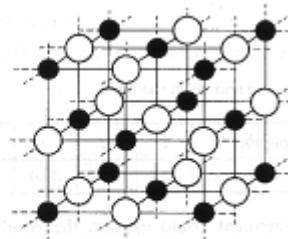
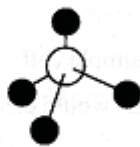
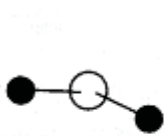

In which row are the compounds correctly named?

	1	2	3	4
<b>A</b>	ammonia	sodium chloride	methane	water
<b>B</b>	methane	ammonia	sodium chloride	water
<b>C</b>	water	ammonia	methane	sodium chloride
<b>D</b>	water	methane	ammonia	sodium chloride



- 27 Sulfur undergoes changes when it reacts with air and water. The substances that sulfur form are represented in the following stages.

Stage 1  
S

Stage 2  
SO<sub>2</sub>

Stage 3  
SO<sub>3</sub>

Stage 4  
H<sub>2</sub>SO<sub>4</sub>

Which of the following shows the correct change in oxidation states of sulfur in each stage of the process?

	S	SO <sub>2</sub>	SO <sub>3</sub>	H <sub>2</sub> SO <sub>4</sub>
<b>A</b>	0	+2	+6	+8
<b>B</b>	0	+4	+6	+6
<b>C</b>	+2	0	+6	+6
<b>D</b>	+6	+6	+2	0

- 28 Which statements about the pollutant carbon monoxide are correct?

- 1 It is a colourless and odourless gas.
- 2 It is formed by the complete combustion of natural gas.
- 3 It reacts with the haemoglobin in the blood and reduce the transport of oxygen.

- A** 1 and 2 only  
**B** 2 and 3 only  
**C** 1 and 3 only  
**D** 1, 2 and 3

- 29 The diagram shows a complete circuit.

Which solid, when placed between **P** and **Q**, would cause the light bulb **L** to light up?

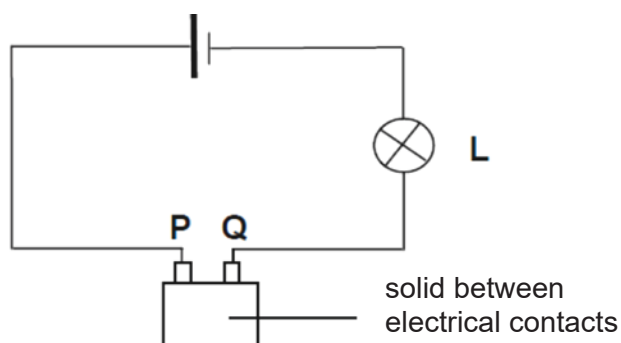

- A** copper  
**B** hydrogen fluoride  
**C** sodium chloride  
**D** sulphur



- 33 The diagram shows a cooling curve of steam.

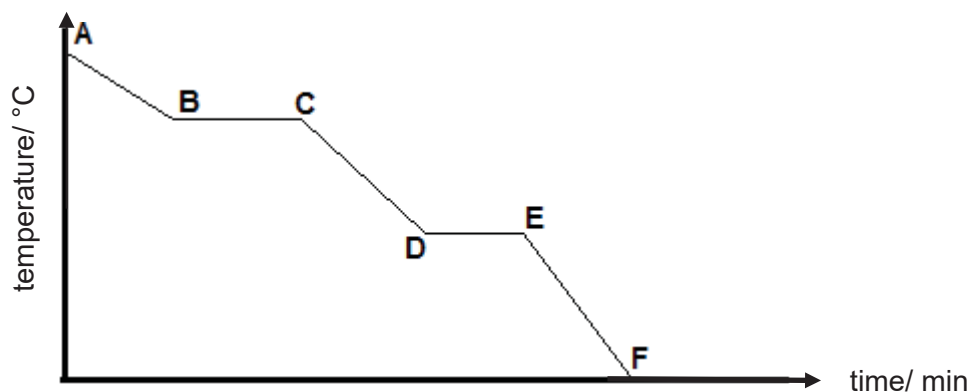

Which of the following options correctly describes the changes that occur between points C to D?

	separation of particles	energy of particles	attractive forces between particles
<b>A</b>	decreases	increases	decreases
<b>B</b>	decreases	decreases	increases
<b>C</b>	increases	increases	decreases
<b>D</b>	increases	decreases	increases

- 34 An element has an atomic number of 4.

Which statement about this element is correct?

- A** It forms ions by losing electrons.
- B** It has four occupied electron shells in each of its atoms.
- C** It is an unreactive gas at room temperature and pressure.
- D** It is found in Group IV of the Periodic Table.

- 35 An element X forms an ion of  $X^{2+}$ .

Which group of the Periodic Table is this element found in?

- A** Group I
- B** Group II
- C** Group V
- D** Group VI

- 36 Some zinc carbonate was reacted with excess dilute nitric acid.

The graph shows the volume of carbon dioxide gas evolved at 20 second intervals until the reaction has finished. Graph 1 shows the results obtained from this reaction.

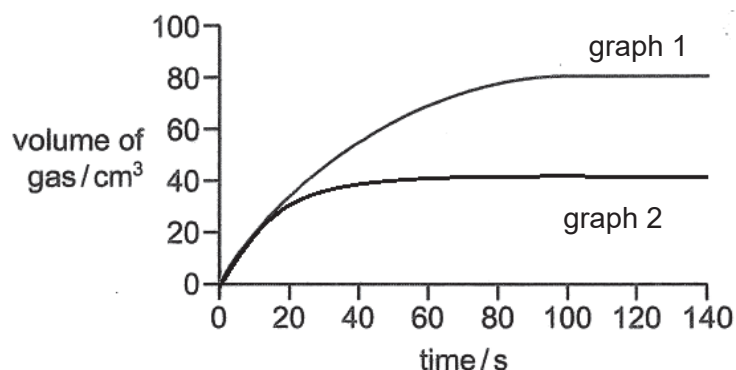

Which of the following could have been changed to produce graph 2?

- A The concentration of acid was doubled.
  - B The concentration of acid was halved.
  - C The mass of zinc carbonate was halved.
  - D The particle size of the zinc carbonate was doubled.
- 37 The reaction between hydrochloric acid and calcium carbonate is shown.



What volume of 1.0 mol/dm<sup>3</sup> hydrochloric acid is needed to react completely with 1.0 g of calcium carbonate ( $M_r = 100$ )?

- A 10 cm<sup>3</sup>
  - B 20 cm<sup>3</sup>
  - C 100 cm<sup>3</sup>
  - D 200 cm<sup>3</sup>
- 38 Which of the following substances is **not** present in the reaction during the extraction of iron?
- A calcium oxide
  - B calcium carbonate
  - C calcium hydroxide
  - D calcium metasilicate



## The Periodic Table of Elements

		Group																																																																																																																																																																																																																																																																																																																																																																																																																																																																																														
I	II	III	IV	V	VI	VII	0																																																																																																																																																																																																																																																																																																																																																																																																																																																																																									
3 Li lithium 7	4 Be beryllium 9	<div style="display: flex; justify-content: space-around; align-items: center;"> <div style="border: 1px solid black; padding: 5px;">           1 H hydrogen 1         </div> <div style="border: 1px solid black; padding: 5px;">           proton (atomic) number atomic symbol name relative atomic mass         </div> </div>										2 He helium 4																																																																																																																																																																																																																																																																																																																																																																																																																																																																																				
11 Na sodium 23	12 Mg magnesium 24	13 Al aluminium 27	14 Si silicon 28	15 P phosphorus 31	16 S sulfur 32	17 Cl chlorine 35.5	18 Ar argon 40	19 K potassium 39	20 Ca calcium 40	21 Sc scandium 45	22 Ti titanium 48	23 V vanadium 51	24 Cr chromium 52	25 Mn manganese 55	26 Fe iron 56	27 Co cobalt 59	28 Ni nickel 59	29 Cu copper 64	30 Zn zinc 65	31 Ga gallium 70	32 Ge germanium 73	33 As arsenic 75	34 Se selenium 79	35 Br bromine 80	36 Kr krypton 84																																																																																																																																																																																																																																																																																																																																																																																																																																																																							
37 Rb rubidium 85	38 Sr strontium 88	39 Y yttrium 89	40 Zr zirconium 91	41 Nb niobium 93	42 Mo molybdenum 96	43 Tc technetium -	44 Ru ruthenium 101	45 Rh rhodium 103	46 Pd palladium 106	47 Ag silver 108	48 Cd cadmium 112	49 In indium 115	50 Sn tin 119	51 Sb antimony 122	52 Te tellurium 128	53 I iodine 127	54 Xe xenon 131	55 Cs caesium 133	56 Ba barium 137	57 – 71 lanthanoids	72 Hf hafnium 178	73 Ta tantalum 181	74 W tungsten 184	75 Re rhenium 186	76 Os osmium 190	77 Ir iridium 192	78 Pt platinum 195	79 Au gold 197	80 Hg mercury 201	81 Tl thallium 204	82 Pb lead 207	83 Bi bismuth 209	84 Po polonium -	85 At astatine -	86 Rn radon -																																																																																																																																																																																																																																																																																																																																																																																																																																																													
87 Fr francium -	88 Ra radium -	89 – 103 actinoids	104 Rf Rutherfordium -	105 Db dubnium -	106 Sg seaborgium -	107 Bh bohrium -	108 Hs hassium -	109 Mt meitnerium -	110 Ds darmstadtium -	111 Rg roentgenium -	112 Cn copernicium -	114 Fl flerovium -	116 Lv livermorium -	117 Ts tennessine -	118 Og oganesson -	119 Uue unbinilium -	120 Uuo unbinilium -	121 Uut ununilium -	122 Uuq ununnilium -	123 Uub ununseptium -	124 Uuq ununquadium -	125 Uup ununpentium -	126 Uuq ununhexium -	127 Uuh ununheptium -	128 Uuo ununoctium -	129 Uuq ununnonium -	130 Uuo unundecium -	131 Uuq ununtridecium -	132 Uub ununtridecium -	133 Uut ununtridecium -	134 Uuq ununtridecium -	135 Uuh ununtridecium -	136 Uuo ununtridecium -	137 Uuq ununtridecium -	138 Uuh ununtridecium -	139 Uuo ununtridecium -	140 Uuq ununtridecium -	141 Uuh ununtridecium -	142 Uuo ununtridecium -	143 Uuq ununtridecium -	144 Uuh ununtridecium -	145 Uuo ununtridecium -	146 Uuq ununtridecium -	147 Uuh ununtridecium -	148 Uuo ununtridecium -	149 Uuq ununtridecium -	150 Uuh ununtridecium -	151 Uuo ununtridecium -	152 Uuq ununtridecium -	153 Uuh ununtridecium -	154 Uuo ununtridecium -	155 Uuq ununtridecium -	156 Uuh ununtridecium -	157 Uuo ununtridecium -	158 Uuq ununtridecium -	159 Uuh ununtridecium -	160 Uuo ununtridecium -	161 Uuq ununtridecium -	162 Uuh ununtridecium -	163 Uuo ununtridecium -	164 Uuq ununtridecium -	165 Uuh ununtridecium -	166 Uuo ununtridecium -	167 Uuq ununtridecium -	168 Uuh ununtridecium -	169 Uuo ununtridecium -	170 Uuq ununtridecium -	171 Uuh ununtridecium -	172 Uuo ununtridecium -	173 Uuq ununtridecium -	174 Uuh ununtridecium -	175 Uuo ununtridecium -	176 Uuq ununtridecium -	177 Uuh ununtridecium -	178 Uuo ununtridecium -	179 Uuq ununtridecium -	180 Uuh ununtridecium -	181 Uuo ununtridecium -	182 Uuq ununtridecium -	183 Uuh ununtridecium -	184 Uuo ununtridecium -	185 Uuq ununtridecium -	186 Uuh ununtridecium -	187 Uuo ununtridecium -	188 Uuq ununtridecium -	189 Uuh ununtridecium -	190 Uuo ununtridecium -	191 Uuq ununtridecium -	192 Uuh ununtridecium -	193 Uuo ununtridecium -	194 Uuq ununtridecium -	195 Uuh ununtridecium -	196 Uuo ununtridecium -	197 Uuq ununtridecium -	198 Uuh ununtridecium -	199 Uuo ununtridecium -	200 Uuq ununtridecium -	201 Uuh ununtridecium -	202 Uuo ununtridecium -	203 Uuq ununtridecium -	204 Uuh ununtridecium -	205 Uuo ununtridecium -	206 Uuq ununtridecium -	207 Uuh ununtridecium -	208 Uuo ununtridecium -	209 Uuq ununtridecium -	210 Uuh ununtridecium -	211 Uuo ununtridecium -	212 Uuq ununtridecium -	213 Uuh ununtridecium -	214 Uuo ununtridecium -	215 Uuq ununtridecium -	216 Uuh ununtridecium -	217 Uuo ununtridecium -	218 Uuq ununtridecium -	219 Uuh ununtridecium -	220 Uuo ununtridecium -	221 Uuq ununtridecium -	222 Uuh ununtridecium -	223 Uuo ununtridecium -	224 Uuq ununtridecium -	225 Uuh ununtridecium -	226 Uuo ununtridecium -	227 Uuq ununtridecium -	228 Uuh ununtridecium -	229 Uuo ununtridecium -	230 Uuq ununtridecium -	231 Uuh ununtridecium -	232 Uuo ununtridecium -	233 Uuq ununtridecium -	234 Uuh ununtridecium -	235 Uuo ununtridecium -	236 Uuq ununtridecium -	237 Uuh ununtridecium -	238 Uuo ununtridecium -	239 Uuq ununtridecium -	240 Uuh ununtridecium -	241 Uuo ununtridecium -	242 Uuq ununtridecium -	243 Uuh ununtridecium -	244 Uuo ununtridecium -	245 Uuq ununtridecium -	246 Uuh ununtridecium -	247 Uuo ununtridecium -	248 Uuq ununtridecium -	249 Uuh ununtridecium -	250 Uuo ununtridecium -	251 Uuq ununtridecium -	252 Uuh ununtridecium -	253 Uuo ununtridecium -	254 Uuq ununtridecium -	255 Uuh ununtridecium -	256 Uuo ununtridecium -	257 Uuq ununtridecium -	258 Uuh ununtridecium -	259 Uuo ununtridecium -	260 Uuq ununtridecium -	261 Uuh ununtridecium -	262 Uuo ununtridecium -	263 Uuq ununtridecium -	264 Uuh ununtridecium -	265 Uuo ununtridecium -	266 Uuq ununtridecium -	267 Uuh ununtridecium -	268 Uuo ununtridecium -	269 Uuq ununtridecium -	270 Uuh ununtridecium -	271 Uuo ununtridecium -	272 Uuq ununtridecium -	273 Uuh ununtridecium -	274 Uuo ununtridecium -	275 Uuq ununtridecium -	276 Uuh ununtridecium -	277 Uuo ununtridecium -	278 Uuq ununtridecium -	279 Uuh ununtridecium -	280 Uuo ununtridecium -	281 Uuq ununtridecium -	282 Uuh ununtridecium -	283 Uuo ununtridecium -	284 Uuq ununtridecium -	285 Uuh ununtridecium -	286 Uuo ununtridecium -	287 Uuq ununtridecium -	288 Uuh ununtridecium -	289 Uuo ununtridecium -	290 Uuq ununtridecium -	291 Uuh ununtridecium -	292 Uuo ununtridecium -	293 Uuq ununtridecium -	294 Uuh ununtridecium -	295 Uuo ununtridecium -	296 Uuq ununtridecium -	297 Uuh ununtridecium -	298 Uuo ununtridecium -	299 Uuq ununtridecium -	300 Uuh ununtridecium -	301 Uuo ununtridecium -	302 Uuq ununtridecium -	303 Uuh ununtridecium -	304 Uuo ununtridecium -	305 Uuq ununtridecium -	306 Uuh ununtridecium -	307 Uuo ununtridecium -	308 Uuq ununtridecium -	309 Uuh ununtridecium -	310 Uuo ununtridecium -	311 Uuq ununtridecium -	312 Uuh ununtridecium -	313 Uuo ununtridecium -	314 Uuq ununtridecium -	315 Uuh ununtridecium -	316 Uuo ununtridecium -	317 Uuq ununtridecium -	318 Uuh ununtridecium -	319 Uuo ununtridecium -	320 Uuq ununtridecium -	321 Uuh ununtridecium -	322 Uuo ununtridecium -	323 Uuq ununtridecium -	324 Uuh ununtridecium -	325 Uuo ununtridecium -	326 Uuq ununtridecium -	327 Uuh ununtridecium -	328 Uuo ununtridecium -	329 Uuq ununtridecium -	330 Uuh ununtridecium -	331 Uuo ununtridecium -	332 Uuq ununtridecium -	333 Uuh ununtridecium -	334 Uuo ununtridecium -	335 Uuq ununtridecium -	336 Uuh ununtridecium -	337 Uuo ununtridecium -	338 Uuq ununtridecium -	339 Uuh ununtridecium -	340 Uuo ununtridecium -	341 Uuq ununtridecium -	342 Uuh ununtridecium -	343 Uuo ununtridecium -	344 Uuq ununtridecium -	345 Uuh ununtridecium -	346 Uuo ununtridecium -	347 Uuq ununtridecium -	348 Uuh ununtridecium -	349 Uuo ununtridecium -	350 Uuq ununtridecium -	351 Uuh ununtridecium -	352 Uuo ununtridecium -	353 Uuq ununtridecium -	354 Uuh ununtridecium -	355 Uuo ununtridecium -	356 Uuq ununtridecium -	357 Uuh ununtridecium -	358 Uuo ununtridecium -	359 Uuq ununtridecium -	360 Uuh ununtridecium -	361 Uuo ununtridecium -	362 Uuq ununtridecium -	363 Uuh ununtridecium -	364 Uuo ununtridecium -	365 Uuq ununtridecium -	366 Uuh ununtridecium -	367 Uuo ununtridecium -	368 Uuq ununtridecium -	369 Uuh ununtridecium -	370 Uuo ununtridecium -	371 Uuq ununtridecium -	372 Uuh ununtridecium -	373 Uuo ununtridecium -	374 Uuq ununtridecium -	375 Uuh ununtridecium -	376 Uuo ununtridecium -	377 Uuq ununtridecium -	378 Uuh ununtridecium -	379 Uuo ununtridecium -	380 Uuq ununtridecium -	381 Uuh ununtridecium -	382 Uuo ununtridecium -	383 Uuq ununtridecium -	384 Uuh ununtridecium -	385 Uuo ununtridecium -	386 Uuq ununtridecium -	387 Uuh ununtridecium -	388 Uuo ununtridecium -	389 Uuq ununtridecium -	390 Uuh ununtridecium -	391 Uuo ununtridecium -	392 Uuq ununtridecium -	393 Uuh ununtridecium -	394 Uuo ununtridecium -	395 Uuq ununtridecium -	396 Uuh ununtridecium -	397 Uuo ununtridecium -	398 Uuq ununtridecium -	399 Uuh ununtridecium -	400 Uuo ununtridecium -	401 Uuq ununtridecium -	402 Uuh ununtridecium -	403 Uuo ununtridecium -	404 Uuq ununtridecium -	405 Uuh ununtridecium -	406 Uuo ununtridecium -	407 Uuq ununtridecium -	408 Uuh ununtridecium -	409 Uuo ununtridecium -	410 Uuq ununtridecium -	411 Uuh ununtridecium -	412 Uuo ununtridecium -	413 Uuq ununtridecium -	414 Uuh ununtridecium -	415 Uuo ununtridecium -	416 Uuq ununtridecium -	417 Uuh ununtridecium -	418 Uuo ununtridecium -	419 Uuq ununtridecium -	420 Uuh ununtridecium -	421 Uuo ununtridecium -	422 Uuq ununtridecium -	423 Uuh ununtridecium -	424 Uuo ununtridecium -	425 Uuq ununtridecium -	426 Uuh ununtridecium -	427 Uuo ununtridecium -	428 Uuq ununtridecium -	429 Uuh ununtridecium -	430 Uuo ununtridecium -	431 Uuq ununtridecium -	432 Uuh ununtridecium -	433 Uuo ununtridecium -	434 Uuq ununtridecium -	435 Uuh ununtridecium -	436 Uuo ununtridecium -	437 Uuq ununtridecium -	438 Uuh ununtridecium -	439 Uuo ununtridecium -	440 Uuq ununtridecium -	441 Uuh ununtridecium -	442 Uuo ununtridecium -	443 Uuq ununtridecium -	444 Uuh ununtridecium -	445 Uuo ununtridecium -	446 Uuq ununtridecium -	447 Uuh ununtridecium -	448 Uuo ununtridecium -	449 Uuq ununtridecium -	450 Uuh ununtridecium -	451 Uuo ununtridecium -	452 Uuq ununtridecium -	453 Uuh ununtridecium -	454 Uuo ununtridecium -	455 Uuq ununtridecium -	456 Uuh ununtridecium -	457 Uuo ununtridecium -	458 Uuq ununtridecium -	459 Uuh ununtridecium -	460 Uuo ununtridecium -	461 Uuq ununtridecium -	462 Uuh ununtridecium -	463 Uuo ununtridecium -	464 Uuq ununtridecium -	465 Uuh ununtridecium -	466 Uuo ununtridecium -	467 Uuq ununtridecium -	468 Uuh ununtridecium -	469 Uuo ununtridecium -	470 Uuq ununtridecium -	471 Uuh ununtridecium -	472 Uuo ununtridecium -	473 Uuq ununtridecium -	474 Uuh ununtridecium -	475 Uuo ununtridecium -	476 Uuq ununtridecium -	477 Uuh ununtridecium -	478 Uuo ununtridecium -	479 Uuq ununtridecium -	480 Uuh ununtridecium -	481 Uuo ununtridecium -	482 Uuq ununtridecium -	483 Uuh ununtridecium -	484 Uuo ununtridecium -	485 Uuq ununtridecium -	486 Uuh ununtridecium -	487 Uuo ununtridecium -	488 Uuq ununtridecium -	489 Uuh ununtridecium -	490 Uuo ununtridecium -	491 Uuq ununtridecium -	492 Uuh ununtridecium -	493 Uuo ununtridecium -	494 Uuq ununtridecium -	495 Uuh ununtridecium -	496 Uuo ununtridecium -	497 Uuq ununtridecium -	498 Uuh ununtridecium -	499 Uuo ununtridecium -	500 Uuq ununtridecium -	501 Uuh ununtridecium -	502 Uuo ununtridecium -	503 Uuq ununtridecium -	504 Uuh ununtridecium -	505 Uuo ununtridecium -	506 Uuq ununtridecium -	507 Uuh ununtridecium -	508 Uuo ununtridecium -	509 Uuq ununtridecium -	510 Uuh ununtridecium -	511 Uuo ununtridecium -	512 Uuq ununtridecium -	513 Uuh ununtridecium -	514 Uuo ununtridecium -	515 Uuq ununtridecium -	516 Uuh ununtridecium -	517 Uuo ununtridecium -	518 Uuq ununtridecium -	519 Uuh ununtridecium -	520 Uuo ununtridecium -	521 Uuq ununtridecium -	522 Uuh ununtridecium -	523 Uuo ununtridecium -	524 Uuq ununtridecium -	525 Uuh ununtridecium -	526 Uuo ununtridecium -	527 Uuq ununtridecium -	528 Uuh ununtridecium -	529 Uuo ununtridecium -	530 Uuq ununtridecium -	531 Uuh ununtridecium -	532 Uuo ununtridecium -	533 Uuq ununtridecium -	534 Uuh ununtridecium -	535 Uuo ununtridecium -	536 Uuq ununtridecium -	537 Uuh ununtridecium -	538 Uuo ununtridecium -	539 Uuq ununtridecium -	540 Uuh ununtridecium -	541 Uuo ununtridecium -	542 Uuq ununtridecium -	543 Uuh ununtridecium -	544 Uuo ununtridecium -	545 Uuq ununtridecium -	546 Uuh ununtridecium -	547 Uuo ununtridecium -	548 Uuq ununtridecium -	549 Uuh ununtridecium -	550 Uuo ununtridecium -	551 Uuq ununtridecium -	552 Uuh ununtridecium -	553 Uuo ununtridecium -	554 Uuq ununtridecium -	555 Uuh ununtridecium -	556 Uuo ununtridecium -	557 Uuq ununtridecium -	558 Uuh ununtridecium -	559 Uuo ununtridecium -	560 Uuq ununtridecium -	561 Uuh ununtridecium -	562 Uuo ununtridecium -	563 Uuq ununtridecium -	564 Uuh ununtridecium -	565 Uuo ununtridecium -	566 Uuq ununtridecium -	567 Uuh ununtridecium -	568 Uuo ununtridecium -	569 Uuq ununtridecium -	570 Uuh ununtridecium -	571 Uuo ununtridecium -	572 Uuq ununtridecium -	573 Uuh ununtridecium -	574 Uuo ununtridecium -	575 Uuq ununtridecium -	576 Uuh ununtridecium -	577 Uuo ununtridecium -	578 Uuq ununtridecium -	579 Uuh ununtridecium -	580 Uuo ununtridecium -	581 Uuq ununtridecium -	582 Uuh ununtridecium -	583



# Pasir Ris Secondary School

Name	Class	Register Number
------	-------	-----------------

## SECONDARY 4 EXPRESS / 5 NORMAL ACADEMIC MID YEAR EXAMINATION 2018

### SCIENCE (PHYSICS, CHEMISTRY)

5076/03

Paper 3 Chemistry  
Monday 0800 – 0915

07 May 2018  
1 hour 15 minutes

Candidates answer on the Question Paper.

No Additional Materials are required.

### READ THESE INSTRUCTIONS FIRST

Write your name, class and register number on all the work you hand in.  
You may use a soft pencil for any diagrams, graphs, tables or rough working.  
Write in dark blue or black pen.  
Do not use staples, paper clips, glue or correction fluid.

The use of an approved scientific calculator is expected, where appropriate.  
You may use lose marks if you do not show your working or if you do not use appropriate units.

#### Section A

Answer **all** questions.  
Write your answers in the spaces provided on the question paper.

#### Section B

Answer any **two** questions.  
Write your answers in the spaces provided on the question paper.

A copy of the Data Sheet is printed on page 15.  
A copy of the Periodic Table is printed on page 16.

At the end of the examination, fasten all your work securely together.  
The number of marks is given in brackets [ ] at the end of each question or part question.

For Examiner's Use	
Section A	
Total	

This document consists of **16** printed pages, including the cover page.

**Section A**

Answer **all** the questions in the spaces provided.

- 1 (a) Use **three** words from the box below to describe each substance in Table 1.1. The words can be used once, more than once, or not at all.

For  
Examiner's  
Use

solid	liquid	gas	atom	molecule
	element	compound	mixture	ions

**Table 1.1**

substance	diagram	description words
<b>A</b>		1 ..... 2 ..... 3 .....
<b>B</b>		1 ..... 2 ..... 3 .....
<b>C</b>		1 ..... 2 ..... 3 .....

[3]

- (b) (i) Explain why substance **A** will conduct electricity when dissolved in water.

..... [1]

- (ii) Suggest another way of making substance **A** conduct electricity.

..... [1]

- 2 Spots of different coloured dyes were placed along a pencil line on a sheet of chromatography paper. The paper was then placed in a solvent.

Fig. 2.1 shows the chromatogram obtained.

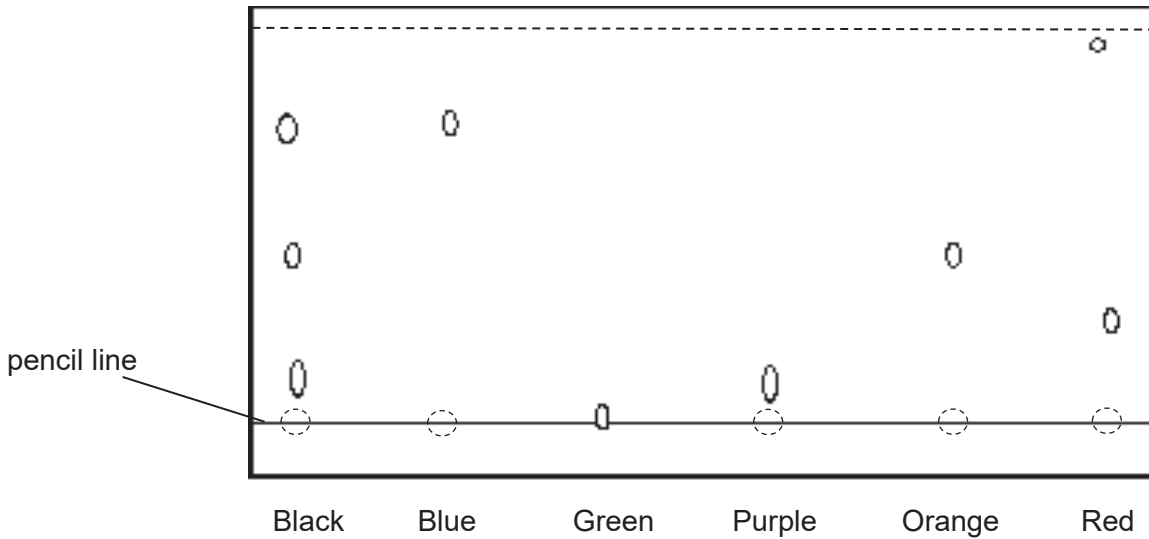

Fig. 2.1

- (a) Which physical property allows chromatography to separate components of the dyes?

..... [1]

- (b) Based on Fig. 2.1, what can be deduced about the components of the black dye?

..... [1]

- (c) Suggest why the start line was drawn in pencil line and **not** in ink for this experiment?

..... [1]  
.....

**3** Hydrogen bromide has a melting point of  $-87\text{ }^{\circ}\text{C}$  and a boiling point of  $-67\text{ }^{\circ}\text{C}$ .

- (a)** Draw a 'dot and cross' diagram to show the arrangement of electrons in a molecule of hydrogen bromide. Show only the outer shell electrons.

[2]

**(b)** Hydrogen bromide dissolves in water to form an acidic solution which is colourless.

- (i)** Give the formula of the ion which causes the acidity.

..... [1]

- (ii)** Describe what is seen when chlorine gas is bubbled through the solution.

.....  
..... [1]

- (iii)** Construct an ionic equation, including state symbols, for the reaction you have described in **(ii)**.

..... [2]

- 4** Zinc blende is an ore that contains mainly zinc sulfide (ZnS). The extraction of zinc from its ore happens in the blast furnace.

The ore of zinc blende is roasted in air (oxygen) to form zinc oxide which is then reduced with carbon monoxide in the blast furnace, similar to the extraction of iron from haematite.

The extraction of zinc can be represented by the equation as shown.

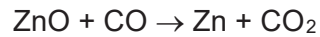

- (a)** State which substance is reduced and give a reason for your answer.

substance reduced .....

reason .....

[2]

- (b)** Zinc produced by the blast furnace is often alloyed to increase its hardness and strength. Brass is an alloy of zinc and copper.

- (i)** Draw the structure of brass in the box provided in Fig. 4.1.



**Fig. 4.1**

[1]

- (ii)** With reference to your drawing in Fig. 4.1, explain why brass is harder and stronger compared to pure zinc.

.....

.....

.....

[2]

- 5 The reaction between copper(II) oxide and hydrogen can be represented by the equation as shown.

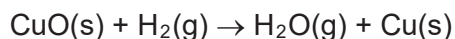

In this reaction, 0.40 g of solid copper(II) oxide was used.

- (a) (i) Calculate the number of moles of copper(II) oxide used in the reaction.

For  
Examiner's  
Use

[1]

- (ii) Hence, determine the number of moles of hydrogen gas is required for all the copper(II) oxide to be used up in the reaction.

[1]

- (b) It is also known that 165 cm<sup>3</sup> of hydrogen gas was used in the reaction.

- (i) Using your answer from (a), determine the limiting reagent.  
Explain your answer clearly by showing all relevant calculations.

[3]

- (ii) Hence or otherwise, calculate the mass of water vapour produced at the end of the reaction.

[2]

- 6 Part of the Periodic Table is shown in Fig. 6.1.  
The letters are **not** the actual chemical symbol of the elements.

<b>V</b>									<b>X</b>				
									<b>Y</b>				
<b>W</b>												<b>Z</b>	

Fig. 6.1

For each of the following statements, decide whether the statement is true or false and state a reason for your decision.

- (a) **W** is more metallic than **Z**.

.....  
..... [1]

- (b) **V** is less reactive than **W**.

.....  
..... [1]

- (c) **V** has a lower melting point than **W**.

.....  
..... [1]

- (d) **X** has more electron shells than **Y**.

.....  
..... [1]

7 Study the flowchart in Fig. 7.1 and answer the following questions.

For  
Examiner's  
Use

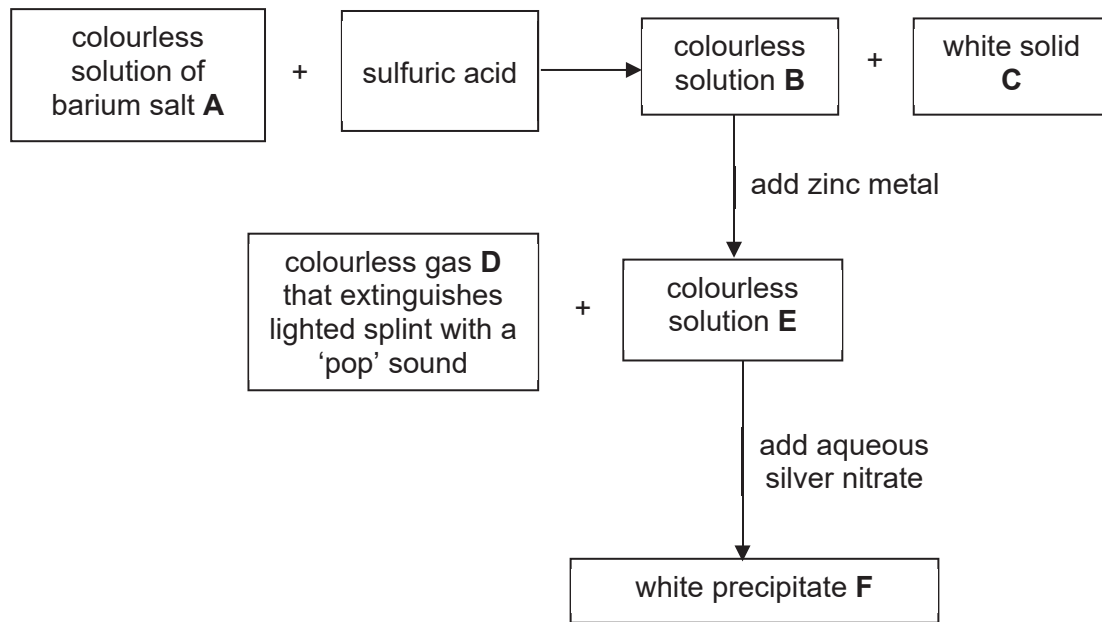

Fig. 7.1

(a) Identify substances **A** to **F**.

**A** .....

**B** .....

**C** .....

**D** .....

**E** .....

**F** .....

[6]

(b) Write a balanced chemical equation for any **one** of the reactions described in Fig. 7.1.

.....

[2]

- 8 (a) A chemical company makes salts for use in industries. Table 8.1 shows some names and formulae of salts with the names of the acids and other compounds used to make them.

Complete the table by writing the missing information.

**Table 8.1**

name of salt	formula of salt	name of acid used to make salt	name of the other compound used to make salt
sodium sulfate	$\text{Na}_2\text{SO}_4$		
potassium phosphate	$\text{K}_3\text{PO}_4$	phosphoric acid	
silver chloride	$\text{AgCl}$		
calcium phosphate		phosphoric acid	calcium hydroxide

[3]

- (b) Fig. 8.2 shows a rusted car. However, not all the parts have rusted. The areas that have not rusted are either painted or have plastic coatings.



Fig. 8.2

Explain how the paint and plastic coating can slow down rusting.

.....

.....

[2]

- (c) Harmful gases released into the atmosphere can form acid rain which speeds up rusting. Name **one** such gas which causes acid rain and state its source.

.....

[2]

## Section B

For  
Examiner's  
Use

Answer any **two** questions in this section.

Write your answers in the spaces provided.

- 9** Read the information about chlorine.

Chlorine ranks among the top ten chemicals produced today. Chlorine is produced by passing an electric current through a concentrated solution of sodium chloride or through molten sodium chloride. This process is one of the most important commercial processes in industry. Chlorine, in one form or another, is added to most swimming pools, spas, and public water supplies because it kills bacteria that cause disease. Many people also use chlorine to bleach their clothes. Large paper and pulp mills use chlorine to bleach their products.

Two naturally occurring isotopes of chlorine exist, chlorine-35 and chlorine-37. Chlorine exists commonly both in the Earth's crust and in seawater as sodium chloride. Smaller amounts of potassium chloride and magnesium chloride also occur in seawater.

Chlorine is very reactive. The reaction between chlorine and other elements can often be vigorous. For example, chlorine reacts explosively with hydrogen to form hydrogen chloride.

- (a)** The information contains examples of a mixture.  
Identify **two** mixtures in the information.

.....

[1]

- (b)** The chemical symbols of the two chlorine isotopes are shown below.

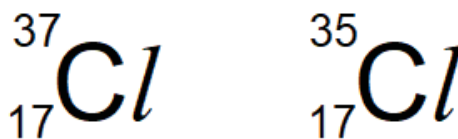

Compare and contrast the structures of the nuclei in chlorine isotopes.

.....

.....

.....

[2]

(c) Magnesium burns in chlorine gas to produce magnesium chloride.

(i) Complete Table 9.1 which gives information about the two ions in magnesium chloride.

**Table 9.1**

name of ion	number of protons	number of neutrons	number of electrons	electronic structure
magnesium ion	12			2,8
chloride ion	17	18		

[2]

(ii) Draw a 'dot' and cross diagram to show the arrangement of electrons in magnesium chloride. Show only outer shell electrons.

[2]

(d) Chlorine can react with hydrogen to form hydrogen chloride. Hydrogen chloride is a gas at room temperature.

(i) In terms of electrons, describe the bonding in hydrogen chloride.

.....  
 .....

[1]

(ii) At room temperature, magnesium chloride is a solid while hydrogen chloride is a gas.

Use your knowledge of the bonding in magnesium chloride and hydrogen chloride to explain the difference in physical state.

.....  
 .....  
 .....  
 .....  
 .....

[2]

10 (a) Hydrochloric acid is used for rust removal while sodium hydroxide is used in detergents.

For  
Examiner's  
Use

- (i) State the colour of Universal Indicator in dilute hydrochloric acid and in aqueous sodium hydroxide.

.....  
.....

[2]

- (ii) Explain briefly, in terms of ions in solution, the reason for the difference in acidity and alkalinity of hydrochloric acid and sodium hydroxide solutions.

.....  
.....

[2]

- (iii) The reaction between hydrochloric acid and magnesium metal produces a soluble salt, magnesium chloride.  
Describe the steps to obtain a pure sample of magnesium chloride from the reaction.

.....  
.....  
.....  
.....  
.....  
.....

[4]

- (b) In an experiment, 20.0 cm<sup>3</sup> of 1.50 mol/dm<sup>3</sup> sodium hydroxide exactly neutralised 25.0 cm<sup>3</sup> of hydrochloric acid. Using the chemical equation provided for the reaction, calculate the concentration of the hydrochloric acid used.

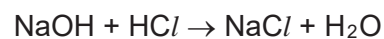

[2]

- 11 (a) Fig. 11.1 shows the speed of reaction between calcium carbonate and hydrochloric acid in two different experiments.

For  
Examiner's  
Use

Experiment 1 was performed using 10 g of powdered calcium carbonate.  
Experiment 2 was performed using 10 g calcium carbonate in lumps.

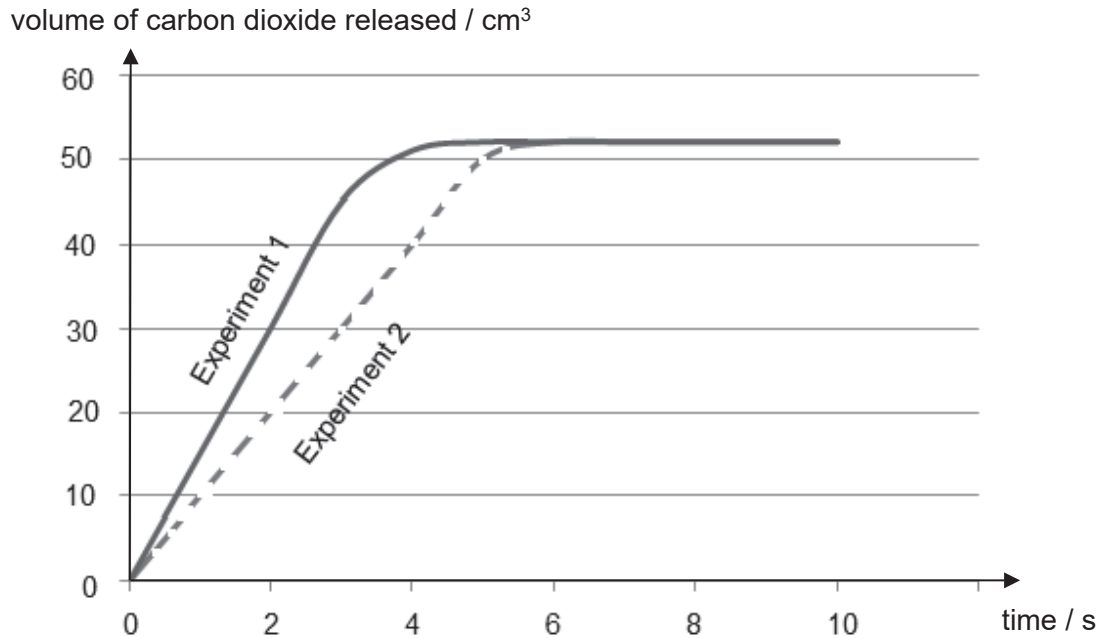

Fig. 11.1

- (i) Based on the graphs, compare the speed of reaction for the two experiments.

.....  
.....

[1]

- (ii) Use your knowledge of reacting particles to explain why the particle size of calcium carbonate affects the speed of reaction.

.....  
.....  
.....  
.....

[2]

- (iii) Write a balanced chemical equation, including state symbols, for the reaction between calcium carbonate and hydrochloric acid.

.....

[2]

(b) Sketch on Fig. 11.1 the speed of reaction for **5 g of powdered calcium carbonate**. Label this 'Experiment 3'. [1]

(c) The temperature of the mixtures increased during the reaction in both experiments 1 and 2.

(i) Suggest whether the reactions are exothermic or endothermic.

..... [1]

(ii) Explain in terms of bond breaking and bond forming for your answer in c (i).

.....  
.....  
.....  
.....  
.....  
.....  
..... [2]

(iii) Suggest a method that can be used to accurately determine that all the acid has been used up during the reaction.

..... [1]

**End of Paper**

**DATA SHEET**

## Colours of Some Common Metal Hydroxides

calcium hydroxide	white
copper(II) hydroxide	light blue
iron(II) hydroxide	green
iron(III) hydroxide	red-brown
lead(II) hydroxide	white
zinc hydroxide	white

# The Periodic Table of Elements

		Group															
I	II	III	IV	V	VI	VII	0										
3 Li lithium 7	4 Be beryllium 9	1 H hydrogen 1	5 B boron 11	6 C carbon 12	7 N nitrogen 14	8 O oxygen 16	9 F fluorine 19	10 Ne neon 20									
11 Na sodium 23	12 Mg magnesium 24	13 Al aluminium 27	14 Si silicon 28	15 P phosphorus 31	16 S sulfur 32	17 Cl chlorine 35.5	18 Ar argon 40										
19 K potassium 39	20 Ca calcium 40	21 Sc scandium 45	22 Ti titanium 48	23 V vanadium 51	24 Cr chromium 52	25 Mn manganese 55	26 Fe iron 56	27 Co cobalt 59	28 Ni nickel 59	29 Cu copper 64	30 Zn zinc 65	31 Ga gallium 70	32 Ge germanium 73	33 As arsenic 75	34 Se selenium 79	35 Br bromine 80	36 Kr krypton 84
37 Rb rubidium 85	38 Sr strontium 88	39 Y yttrium 89	40 Zr zirconium 91	41 Nb niobium 93	42 Mo molybdenum 96	43 Tc technetium -	44 Ru ruthenium 101	45 Rh rhodium 103	46 Pd palladium 106	47 Ag silver 108	48 Cd cadmium 112	49 In indium 115	50 Sn tin 119	51 Sb antimony 122	52 Te tellurium 128	53 I iodine 127	54 Xe xenon 131
55 Cs caesium 133	56 Ba barium 137	57 – 71 lanthanoids	72 Hf hafnium 178	73 Ta tantalum 181	74 W tungsten 184	75 Re rhenium 186	76 Os osmium 190	77 Ir iridium 192	78 Pt platinum 195	79 Au gold 197	80 Hg mercury 201	81 Tl thallium 204	82 Pb lead 207	83 Bi bismuth 209	84 Po polonium -	85 At astatine -	86 Rn radon -
87 Fr francium -	88 Ra radium -	89 – 103 actinoids	104 Rf Rutherfordium -	105 Db dubnium -	106 Sg seaborgium -	107 Bh bohrium -	108 Hs hassium -	109 Mt meitnerium -	110 Ds darmstadtium -	111 Rg roentgenium -	112 Cn copernicium -	114 Fl flerovium -	116 Lv livermorium -	117 Ts tennessine -	118 Og oganeson -	119 Uue unbinilium -	120 Uuo unbinilium -

**Key**

proton (atomic) number  
atomic symbol  
name  
relative atomic mass

lanthanoids		actinoids	
57 La lanthanum 139	58 Ce cerium 140	59 Pr praseodymium 141	60 Nd neodymium 144
89 Ac actinium -	90 Th thorium 232	91 Pa protactinium 231	92 U uranium 238
67 Ho holmium 165	68 Er erbium 167	69 Tm thulium 169	70 Yb ytterbium 173
71 Lu lutetium 175	72 Lu lutetium 175	73 Lu lutetium 175	74 Lu lutetium 175

The volume of one mole of any gas is 24 dm<sup>3</sup> at room temperature and pressure (r.t.p.).



Answers for Paper 1							
21	A	26	C	31	D	36	C
22	A	27	B	32	A	37	B
23	D	28	C	33	B	38	C
24	A	29	A	34	A	39	B
25	C	30	B	35	B	40	C



SECONDARY 4 EXPRESS  
MID-YEAR EXAMINATION 2018

---

SCIENCE (CHEMISTRY)

5076

Paper 1: Friday 0800 – 0900

04 May 2018

Paper 3: Monday 0800 - 0915

07 May 2018

20 + 65 marks

---

## MARKING SCHEME

---

This document consists of **14** printed pages (inclusive of this page).

## Section A: Structured Questions [45 marks]

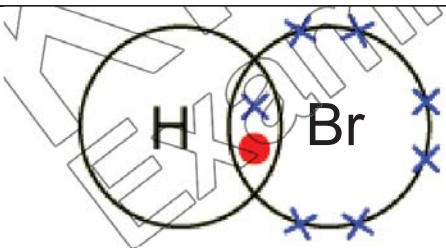
1	(a)	description words			[3]
		1 solid 2 ions 3 compound	Students incorrectly state <b>mixture</b> due to the different charges.		
		1 liquid 2 element 3 atom	Students incorrectly state <b>solid</b> due to the connecting atoms or <b>molecule</b>		
		1 gas 2 compound 3 molecule	Students incorrectly state <b>mixture</b> due to the different coloured shapes failing to appreciate the line or as <b>atoms</b> .		
		Any order			
				1 mark for every 3 correct answers	
	(b)	(i)	Presence of mobile ions to act as charge carriers to enable conduction of electricity	Missing key terms of mobile ions act as charge carriers. <b>Students state free electrons which is reserved for metals.</b>	[1]
		(ii)	Heating A till it melts / A is in molten state.	Students state electrolysis and electroplating it as a method.	[1]
			[Total: 5 marks]		
2	(a)	Different solubilities of components in solvent		Many students wrote solubility as a one-word response. Failing to state solubility of the dyes.	[1]
	(b)	Contains blue, purple and orange		Most who got wrong failed to indicate blue as well as they felt it wasn't perfectly in line.	[1]
	(c)	Graphite/Carbon in the pencil is insoluble in the solvent and would not affect the results.		Students failed to answer question of why pencil was used by only stating why ink is not used. Some used 'lead' as a term to explain about the carbon from pencil.	[1]
			[Total: 3 Marks]		
3	(a)			Most could not recall how to draw the bromine electrons properly. Left blank. Legend stated only as hydrogen/bromine	[2]

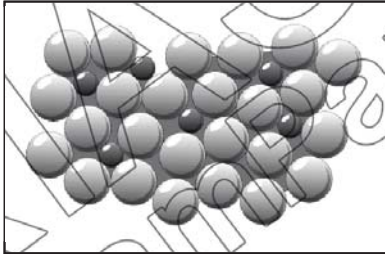
	(b)				
		(i)	H <sup>+</sup>	Students wrote equations of HBr or H <sup>+</sup> .	[1]
		(ii)	Colourless solutions starts to turn reddish - brown	Students described the displacement reaction itself rather than colour observations. Some stated yellow instead of reddish brown.	[1]
		(iii)	$\text{Cl}_2(\text{g}) + 2\text{Br}^-(\text{aq}) \rightarrow 2\text{Cl}^-(\text{aq}) + \text{Br}_2(\text{aq})$ <p>[1] – correct chemical formula/ions [1] – correct state symbols (2<sup>nd</sup> mark is only awarded if the 1<sup>st</sup> mark is given)</p>	Very poorly done. 98% could not do this question and could not balance equation. Need to revisit this topic.	[2]
				[Total: 6 marks]	
4	(a)		<p>Substance reduced: ZnO has been reduced [1] Reason: ZnO has lost an oxygen atom to form Zn / oxidation number of Zn has decreased from +2 in ZnO to 0 in Zn. [1]</p>	<p><b>substance reduced:</b> most incorrectly state as just Zn. <b>Reason:</b> students are able to explain the loss of oxygen to identify the substance reduced. However, their phrasing is wrong using <i>oxygen has been reduced from zinc oxide</i>.</p>	[2]
	(b)	(i)		<p>most students who made mistakes drew orderly arranged atoms or did not differentiate the size of the atoms enough. the size of the atoms enough. Labelling might help.</p>	[1]
		(ii)	<p>The <u>different sized atoms disrupts the orderly arrangement</u> [1] of pure metal. This makes it <u>harder for the layers to slide over one another</u> [1] thereby making it harder.</p>	<p>Most fail to get the full marks by either omitting <i>different size disrupts orderly arrangement</i>.</p>	[2]
				[Total: 5 marks]	
5	(a)	(i)	<p>Mr of CuO = 64 + 16 = 80</p> <p>No. of moles of CuO = <math>\frac{0.40}{80}</math> = 0.0050 moles</p>		[1]

		(ii)	Mole ratio, CuO:H <sub>2</sub> is 1:1, hence <u>0.0050 moles of H<sub>2</sub> is required</u>	Students fail to state why the value is same as a(i).	[1]
	(b)	(i)	No. of moles of hydrogen gas used = $\frac{165}{24000}$ = <u>0.006875moles</u> [1] Mole ratio, CuO:H <sub>2</sub> is 1:1 <u>0.005mole of CuO requires only 0.005 moles of H<sub>2</sub>. However, 0.006875moles of H<sub>2</sub> is used. Hence H<sub>2</sub> is in excess.</u> [1]  <u>CuO is the limiting reagent.</u> [1]	Quite a large number of students had not done this part as they forgot to change cm <sup>3</sup> to dm <sup>3</sup> . They also had forgotten the formula.  Lastly, they incorrectly associate CuO and H <sub>2</sub> mole directly by looking which is more rather than by looking at amount of H <sub>2</sub> available vs needed.	[3]
		(ii)	Mr of water vapour = 2 + 16 = 18  Mole ratio of CuO:H <sub>2</sub> O is 1:1. Hence 0.005mols of water vapour is formed. [1]  Mass of water vapour = 0.005 x 18 = <u>0.09g</u> [1]	Quite a fair number of students erroneously used the amount of hydrogen used in a(i). to calculate the number of moles. 1m was given for method mark.	[2]
				[Total: 7 marks]	
6	(a)		True; In the same Period, <u>metallic character of elements decreases from left to right</u> of PT so W is more metallic than Z.	Most students were able to do this question. However the explanation needs improvement as they only say the Z is a halogen rather than showing less character of a metal.	[1]
	(b)		True; <u>On moving down Group I elements, the reactivity increases</u> so V is less reactive than W.	Most students could do this well.	[1]
	(c)		False; <u>On moving down Group I elements, the melting point of the element decreases</u> so V should have a higher melting point than W.	Quite a fair number of students had forgotten trends of Grp 1	[1]
	(d)		False, <u>On moving down any group, the number of electron shells in the atoms of the element increases</u> so X should have less electron shells than Y.	Almost all students were able to answer this question well.	[1]

		(No mark for reason if 'true/false' is incorrect.)																							
				[Total: 4 marks]																					
7	(a)	A: barium chloride B: hydrochloric acid C: barium sulfate D: hydrogen gas E: zinc chloride F: silver chloride		<b>A</b> students could not identify the acid. <b>B</b> students could not identify the acid as HCl. Most placed Barium sulfate in this option. <b>C</b> most left this blank <b>D</b> all students could identify this <b>E</b> some students were able to identify this but was not able to work backwards. <b>F</b> as above	[6]																				
	(b)	$2\text{AgNO}_3 (\text{aq}) + \text{ZnCl}_2 (\text{aq}) \rightarrow 2\text{AgCl} (\text{s}) + \text{Zn}(\text{NO}_3)_2 (\text{aq})$ $\text{BaCl}_2 (\text{aq}) + \text{H}_2\text{SO}_4 (\text{aq}) \rightarrow \text{BaSO}_4 (\text{s}) + 2\text{HCl} (\text{aq})$ $2\text{HCl} (\text{aq}) + \text{Zn} (\text{s}) \rightarrow \text{ZnCl}_2 (\text{aq}) + \text{H}_2 (\text{g})$		Most students who could not do the above could not write a balanced equation. Some also wrote nonsensical response as the reaction cannot go through.	[2]																				
				[Total: 8 marks]																					
8	(a)	<table border="1"> <thead> <tr> <th>name of salt</th> <th>formula of salt</th> <th>name of acid used to make salt</th> <th>name of the other compound used to make salt</th> </tr> </thead> <tbody> <tr> <td>sodium sulfate</td> <td><math>\text{Na}_2\text{SO}_4</math></td> <td><b>sulfuric acid</b></td> <td><b>sodium oxide/hydroxide/carbonate</b></td> </tr> <tr> <td>potassium phosphate</td> <td><math>\text{K}_3\text{PO}_4</math></td> <td>phosphoric acid</td> <td><b>potassium oxide/hydroxide/carbonate</b></td> </tr> <tr> <td>silver chloride</td> <td><math>\text{AgCl}</math></td> <td><b>hydrochloric acid</b></td> <td><b>silver nitrate</b></td> </tr> <tr> <td>calcium phosphate</td> <td><math>\text{Ca}_3(\text{PO}_4)_2</math>  Few recalled the charge for phosphoric acid</td> <td>phosphoric acid</td> <td>calcium hydroxide</td> </tr> </tbody> </table>			name of salt	formula of salt	name of acid used to make salt	name of the other compound used to make salt	sodium sulfate	$\text{Na}_2\text{SO}_4$	<b>sulfuric acid</b>	<b>sodium oxide/hydroxide/carbonate</b>	potassium phosphate	$\text{K}_3\text{PO}_4$	phosphoric acid	<b>potassium oxide/hydroxide/carbonate</b>	silver chloride	$\text{AgCl}$	<b>hydrochloric acid</b>	<b>silver nitrate</b>	calcium phosphate	$\text{Ca}_3(\text{PO}_4)_2$  Few recalled the charge for phosphoric acid	phosphoric acid	calcium hydroxide	[3]
name of salt	formula of salt	name of acid used to make salt	name of the other compound used to make salt																						
sodium sulfate	$\text{Na}_2\text{SO}_4$	<b>sulfuric acid</b>	<b>sodium oxide/hydroxide/carbonate</b>																						
potassium phosphate	$\text{K}_3\text{PO}_4$	phosphoric acid	<b>potassium oxide/hydroxide/carbonate</b>																						
silver chloride	$\text{AgCl}$	<b>hydrochloric acid</b>	<b>silver nitrate</b>																						
calcium phosphate	$\text{Ca}_3(\text{PO}_4)_2$  Few recalled the charge for phosphoric acid	phosphoric acid	calcium hydroxide																						
	(b)	The paint and plastic coating acts as a barrier [1] to		Most students could identify why the paint can be used to prevent rusting but quite a large number did not state how it acts as a protective layer/ barrier from the reactants.	[2]																				

		Prevent / minimize oxygen and water from coming into contact with iron directly [1]																	
	(c)	Nitrogen dioxide – motor vehicles Sulfur dioxide – factories / coal/ volcanic eruptions	Most correctly stated the gases SO <sub>2</sub> but CO was another incorrect response.	[2]															
			[Total: 7 marks]																
	Section B – Free Response Questions [20 marks]			For Examiner's Use															
9	(a)	Solution of sodium chloride and seawater	Many stated swimming pool, tap but the water was only inferred not mentioned.	[1]															
	(b)	Both have same number of protons, 17. They have different number of neutrons, <u>Cl-35 has 18 neutrons while Cl-17 has 20 neutrons.</u>	Many students correctly stated the the same number in proton but did not elaborate on the difference in the number of neutron through calculation to show how they knew the neutron was different.	[1] [1]															
	(c)	(i)	Table 8.1																
			<table border="1"> <thead> <tr> <th>name of ion</th> <th>number of protons</th> <th>number of neutrons</th> <th>number of electrons</th> <th>electronic structure</th> </tr> </thead> <tbody> <tr> <td>magnesium ion</td> <td></td> <td>12</td> <td>10 Ions mean that there is a difference between proton and electron. Mg loses 2 electrons</td> <td></td> </tr> <tr> <td>chloride ion</td> <td></td> <td></td> <td>18 Chlorine gains one electron</td> <td>2,8,8</td> </tr> </tbody> </table>	name of ion	number of protons	number of neutrons	number of electrons	electronic structure	magnesium ion		12	10 Ions mean that there is a difference between proton and electron. Mg loses 2 electrons		chloride ion			18 Chlorine gains one electron	2,8,8	[2]
name of ion	number of protons	number of neutrons	number of electrons	electronic structure															
magnesium ion		12	10 Ions mean that there is a difference between proton and electron. Mg loses 2 electrons																
chloride ion			18 Chlorine gains one electron	2,8,8															
		(ii)	<p>charges [1], electrons [1]</p> <p>Most failed to draw the proper charges and wrongly indicated the outermost shell for magnesium with 2 electrons.</p>	[2]															

	(d)	(i)	Hydrogen and chlorine <u>share a pair of electrons</u> between them.	Most wrongly stated by just stating it has covalent bonds without describing further.	[1]
		(ii)	Magnesium chloride is a solid at room temperature as <u>a large amount of energy</u> is required to overcome the <u>strong electrostatic forces of attraction between oppositely charged ions</u> .  Hydrogen chloride is a gas at room temperature as only a <u>small amount of energy</u> is required to overcome the <u>weak intermolecular forces of attraction between molecules</u> .	Most students failed to state everything to get full marks. Many confused between structure and bonding. Structure describes how the particles are packed and its movement and arrangement.	[1]  [1]
				[Total : 10 marks]	
10	(a)	(i)	Universal indicator in hydrochloric acid is red while it is purple in sodium hydroxide. Reject orange/yellow for hydrochloric acid and blue for sodium hydroxide	Orange and blue are synonymous for weak acid and alkalis	[2]
		(ii)	There are more H <sup>+</sup> ions than OH <sup>-</sup> ions in acid. [1] There are more OH <sup>-</sup> than H <sup>+</sup> ions in alkaline solutions. [1]	Acids have both types of ions only that there are more of one type than the other. The converse is true.	[2]
		(iii)	<u>Add magnesium/carbonate/oxide in excess to acid</u> [1] <u>Filter the mixture to obtain magnesium as residue</u> and keep the filtrate [1] <u>Heat the filtrate to saturate the solution and allow it to cool</u> to allow crystals to form [1] Dry the crystals between sheets of filter paper [1]	By drawing out the reaction, students can visualise better and not omit the steps.	[4]
	(b)		No. of moles of NaOH = 0.02x1.5 = 0.03 [1] Concentration of HCl = 0.03 / 0.0250 [1] = 1.20 mol/dm <sup>3</sup>		[2]
				[Total: 10 marks]	
11	(a)	(i)	Experiment 1 has a faster rate of reaction than experiment 2. / Experiment 1 took a faster time to complete than experiment 2.	Steeper gradient indicates a faster rate of reaction.	[1]
		(ii)	<u>Powdered</u> calcium carbonate has a <u>larger surface area</u> to volume	Most omitted to state which particle was the smaller one and assumed the reader to	[2]

		ratio / larger total surface area <u>exposed to collisions</u> . [1] Results in <u>higher frequency of effective collisions</u> [1], thus greater speed of reaction.	know. Many used higher <b>probability</b> instead of frequency.	
	(iii)	$\text{CaCO}_3(\text{s}) + 2\text{HCl}(\text{aq}) \rightarrow \text{CaCl}_2(\text{aq}) + \text{CO}_2(\text{g}) + \text{H}_2\text{O}(\text{l})$	Most could not recall reactions between acid and carbonates and the product obtained.	[2]
	(b)		Sizeable number of students failed to label the correct term. Students failed to appreciate the half volume compared to first graph. Students did not follow the reaction speed of the first graph.	[1]
	(c) (i)	Exothermic reactions.	Heat increase is exothermic reaction	[1]
	(ii)	<u>Greater energy is given off when bonds of products are formed</u> [1] then <u>energy taken in from surrounding in breaking bonds</u> [1] of reactants. Hence there is a net increase in temperature.	Students failed to appreciate how bonds of existing compounds need to be broken in order to form new bonds.  Breaking of bonds require energy which is <b>taken in</b> (endo) from surroundings. Forming of bonds require the energy to be <b>given out</b> to surroundings (exo). Since final is exo it means that more energy is given off than taken in.	[2]
	(iii)	Using a pH meter.	<b>accurately</b> = use instrument to measure	[1]
				[Total: 10 marks]

End of Paper

